

**Type:**  
**Job:**  
**Catalog number:**

**Approvals:**

<b>VRB4C</b>	/	/	/	/
Fixture	Electrical Module	Top Cap Finish	Concrete Shaft Finish	Option
See page 2				

**Date:**  
**Page: 1 of 3**

## Specifications

**VRB Models**  
 70 to 100 watt  
 Medium Base Lamps  
 42 watt Compact Fluorescent

**VRB4C - Dual Function Luminaire (Concrete Shaft)**  
 Maximum weight: 115 lb

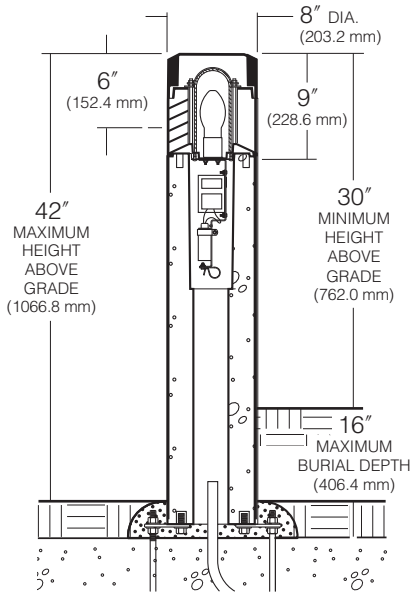

**BASE PLAN  
 VRB  
 CONCRETE SHAFT**

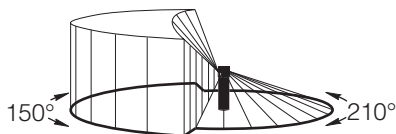
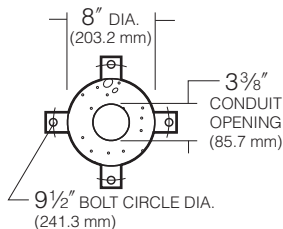

**Flat Top Cap:** One-piece aluminum casting  $\frac{3}{16}$ " minimum thickness, secured to louvers by concealed allen screws in keyhole slots. For relamping access, allen screws shall not require complete removal.

**Louvers:** Aluminum die-cast with horizontal and vertical blades. Stacked horizontal louvers shall provide 210° of downlighting with source cutoff above horizontal. Vertical louvers shall provide 150° of non-cutoff lighting. Horizontal louver blades shall have a  $1\frac{3}{4}$ " depth with a 65° upward pitch from horizontal. Vertical louver blades shall have a  $1\frac{3}{4}$ " depth with a 30° spacing. Louver assembly shall be secured to shaft by four internal tie rod.

**Lamp Enclosure:** One-piece tempered molded glass with internal flutes and full gasketing at bottom edge.

**Socket:** Porcelain medium base socket rated 4KV for HID and incandescent. Plastic socket for Fluorescent.

**Fixture Head:** Allows flow-through ventilation around and above the lamp enclosure.

**Ballast:** Factory mounted to rigid harness for field wiring and suspension from fixture head within the concrete shaft. Wire leads supplied to base. **HID:** High power factor with starting temperatures of -20°F. for PMH and -40°F. for HPS lamp modes. **26W, 32W, 42W Fluorescent:** High power factor with starting temperature of 0°F.

**Anchor Bolts:** Four  $\frac{3}{8}$ " x 10" + 2" zinc plated L-hooks, each with two nuts, washers and a rigid pressed board template.

**Material:** Cement shall conform to current specifications for "Portland Cement." ASTM C150, Type I or II. Aggregates shall meet current requirements of "Specifications for Concrete Aggregates," ASTM C33. Water shall be clean and free from deleterious amounts of silt, oil, acids, alkalis or organic materials. Wire for reinforcement shall conform to ASTM A185. Steel for lugs and plates shall conform to ASTM A36, or A283 grade D.

**Surface:** Medium sand-blasted with anti-graffiti sealer. Available colors are: Charcoal, Brown, Natural Gray or White, integral in concrete mix.

**Cure and Strength:** Allows for completion of the hydration process, and result in a 28 day compressive strength of not less than 4,500 psi.

**Manufacture:** Fiberglass molds used to insure uniform parts. Mold parting lines may be slightly visible in finished parts.

**Anchorage:** Four steel mounting tabs for installation on four  $\frac{1}{2}$ " x 10" + 2" zinc electroplated L-hook anchor bolts. Each anchor bolt is supplied with two nuts, two washers, and a rigid pressed board template.

**Shipment:** Palletized with adequate hold-downs to prevent load movement in transit.

**Finish:** Super TGIC thermoset polyester powder coat paint, 2.5 mil nominal thickness, applied over a titanated zirconium conversion coating; 2500 hour salt spray test endurance rating. Standard colors are Black, Dark Bronze, Light Gray, Stealth Gray™, Platinum Silver, or White. Custom colors are available.

**CAUTION:** Fixtures must be grounded in accordance with national, state and/or local codes. Failure to do so may result in serious personal injury.

### Listings and Ratings

UL cUL 1598 <sup>1</sup>	IP46 Rated	CE	25C Ambient
--------------------------	------------	----	-------------

<sup>1</sup>Suitable for wet locations

KIM LIGHTING RESERVES THE RIGHT TO CHANGE SPECIFICATIONS WITHOUT NOTICE.

Type:

Job:

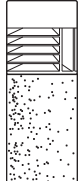

## Standard Features

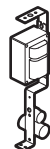
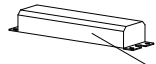
<b>Fixture</b>	Cat. No. <b>VRB4C</b> Dual Function, Concrete Shaft, Flat Top																																																								
<b>Electrical Module</b> <b>PMH</b> = Pulse Start Metal Halide <b>HPS</b> = High Pressure Sodium <b>PL</b> = Compact Fluorescent  <table border="1" data-bbox="186 877 389 976"> <thead> <tr> <th>Lamp Watts</th> <th>Lamp Type</th> <th>Line Volts</th> </tr> </thead> <tbody> <tr> <td>100</td> <td>HPS</td> <td>120</td> </tr> </tbody> </table>  <p><b>NOTE:</b> For lamp/ballast information outside of the U.S.A. and Canada, please consult your local Kim representative.</p>	Lamp Watts	Lamp Type	Line Volts	100	HPS	120	Cat. Nos. for Electrical Modules available: <table border="1" data-bbox="500 688 1458 1018"> <thead> <tr> <th></th> <th><input type="checkbox"/> 70PMH120</th> <th><input type="checkbox"/> 100PMH120</th> <th><input type="checkbox"/> 70HPS120</th> <th><input type="checkbox"/> 100HPS120</th> </tr> </thead> <tbody> <tr> <td></td> <td><input type="checkbox"/> 70PMH208</td> <td><input type="checkbox"/> 100PMH208</td> <td><input type="checkbox"/> 70HPS208</td> <td><input type="checkbox"/> 100HPS208</td> </tr> <tr> <td></td> <td><input type="checkbox"/> 70PMH240</td> <td><input type="checkbox"/> 100PMH240</td> <td><input type="checkbox"/> 70HPS240</td> <td><input type="checkbox"/> 100HPS240</td> </tr> <tr> <td></td> <td><input type="checkbox"/> 70PMH277</td> <td><input type="checkbox"/> 100PMH277</td> <td><input type="checkbox"/> 70HPS277</td> <td><input type="checkbox"/> 100HPS277</td> </tr> <tr> <td></td> <td><input type="checkbox"/> 70PMH347</td> <td><input type="checkbox"/> 100PMH347</td> <td><input type="checkbox"/> 70HPS347</td> <td><input type="checkbox"/> 100HPS347</td> </tr> <tr> <td>Lamp</td> <td>E-17, Coated</td> <td>E-17, Coated</td> <td>ED-17, Coated</td> <td>ED-17, Coated</td> </tr> <tr> <td>Socket</td> <td>Medium Base</td> <td>Medium Base</td> <td>Medium Base</td> <td>Medium Base</td> </tr> <tr> <td>ANSI Ballast Type</td> <td>M-98</td> <td>M-90</td> <td>S-62</td> <td>S-54</td> </tr> </tbody> </table> <table border="1" data-bbox="500 1050 844 1165"> <tbody> <tr> <td></td> <td><input type="checkbox"/> 42PL<sup>1</sup></td> </tr> <tr> <td>Lamp</td> <td>Compact Fluor.</td> </tr> <tr> <td>Socket</td> <td>GX24q-4</td> </tr> </tbody> </table> <p><sup>1</sup>42PL operates one 26, 32, or 42 watt lamp at 120 thru 277 volts (50-60 Hz).  <b>NOTE:</b> Coated lamps are recommended.</p>						<input type="checkbox"/> 70PMH120	<input type="checkbox"/> 100PMH120	<input type="checkbox"/> 70HPS120	<input type="checkbox"/> 100HPS120		<input type="checkbox"/> 70PMH208	<input type="checkbox"/> 100PMH208	<input type="checkbox"/> 70HPS208	<input type="checkbox"/> 100HPS208		<input type="checkbox"/> 70PMH240	<input type="checkbox"/> 100PMH240	<input type="checkbox"/> 70HPS240	<input type="checkbox"/> 100HPS240		<input type="checkbox"/> 70PMH277	<input type="checkbox"/> 100PMH277	<input type="checkbox"/> 70HPS277	<input type="checkbox"/> 100HPS277		<input type="checkbox"/> 70PMH347	<input type="checkbox"/> 100PMH347	<input type="checkbox"/> 70HPS347	<input type="checkbox"/> 100HPS347	Lamp	E-17, Coated	E-17, Coated	ED-17, Coated	ED-17, Coated	Socket	Medium Base	Medium Base	Medium Base	Medium Base	ANSI Ballast Type	M-98	M-90	S-62	S-54		<input type="checkbox"/> 42PL <sup>1</sup>	Lamp	Compact Fluor.	Socket	GX24q-4
Lamp Watts	Lamp Type	Line Volts																																																							
100	HPS	120																																																							
	<input type="checkbox"/> 70PMH120	<input type="checkbox"/> 100PMH120	<input type="checkbox"/> 70HPS120	<input type="checkbox"/> 100HPS120																																																					
	<input type="checkbox"/> 70PMH208	<input type="checkbox"/> 100PMH208	<input type="checkbox"/> 70HPS208	<input type="checkbox"/> 100HPS208																																																					
	<input type="checkbox"/> 70PMH240	<input type="checkbox"/> 100PMH240	<input type="checkbox"/> 70HPS240	<input type="checkbox"/> 100HPS240																																																					
	<input type="checkbox"/> 70PMH277	<input type="checkbox"/> 100PMH277	<input type="checkbox"/> 70HPS277	<input type="checkbox"/> 100HPS277																																																					
	<input type="checkbox"/> 70PMH347	<input type="checkbox"/> 100PMH347	<input type="checkbox"/> 70HPS347	<input type="checkbox"/> 100HPS347																																																					
Lamp	E-17, Coated	E-17, Coated	ED-17, Coated	ED-17, Coated																																																					
Socket	Medium Base	Medium Base	Medium Base	Medium Base																																																					
ANSI Ballast Type	M-98	M-90	S-62	S-54																																																					
	<input type="checkbox"/> 42PL <sup>1</sup>																																																								
Lamp	Compact Fluor.																																																								
Socket	GX24q-4																																																								
<b>Finish</b> Super TGIC thermoset polyester powder coat paint applied over a titanated zirconium conversion coating on fixture top cap.  Concrete shaft surface color is integral in concrete mix. Available in any combination of paint and concrete finishes listed at right.	<b>Top Cap</b> Color: Black Dark Bronze Light Gray Stealth Gray™ Platinum Silver White Custom Color <sup>2</sup> Cat. No.: <input type="checkbox"/> <b>BL</b> <input type="checkbox"/> <b>DB</b> <input type="checkbox"/> <b>LG</b> <input type="checkbox"/> <b>SG</b> <input type="checkbox"/> <b>PS</b> <input type="checkbox"/> <b>WH</b> <input type="checkbox"/> <b>CC</b> <b>Concrete Shaft</b> Color: Brown Charcoal Natural Gray White Cat. No.: <input type="checkbox"/> <b>BR-C</b> <input type="checkbox"/> <b>CH-C</b> <input type="checkbox"/> <b>NG-C</b> <input type="checkbox"/> <b>WH-C</b>  <p><b>NOTE:</b> Black and Dark Bronze colors will produce slightly less louver brightness than Light Gray or White.  <sup>2</sup>Custom colors subject to additional charges, minimum quantities and extended lead times. Available on fixture head only. Consult representative.          Custom color description: _____</p>																																																								
<b>Optional Emergency Battery Back-up</b> Cat. No. <input type="checkbox"/> <b>EM</b> <input type="checkbox"/> <b>No Option</b>	Internal battery pack provides 90 minutes of supplemental light at 23% of initial lamp lumens for 26, 32, or 42 watt compact fluorescent lamps.  <p>battery back-up</p>																																																								

Type:

Job:

Page: 3 of 3

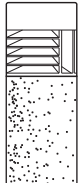

## Standard Features

### Cold-Pack Emergency Battery Pack

- Cat. No.  **EM-CP**  
 **No Option**

The EM-CP option is a temperature controlled ballast designed to maintain operation without interruption within a range of hi/low ambient temperatures, -20°C to +55°C.

Internal Cold-Pack emergency battery pack provides up to 90 minutes of supplemental light. See following table for max. lumens output by lamps.



cold-pack  
battery back-up

<u>Lamp (4-Pin)</u>	<u>1 lamp lumens</u>
42W	750
32W	575
26W	450