

Type:
Job:
Catalog number:

Approvals:

VRB2C /	/	/	/	/
Fixture	Electrical Module	Top Cap Finish	Concrete Shaft Finish	Option
See page 2				

Date:
Page: 1 of 2

Specifications

VRB-LED Models
10 - 20 Diodes

VRB2C - Dual Function Luminaire (Concrete Shaft)
Maximum weight: 115 lb

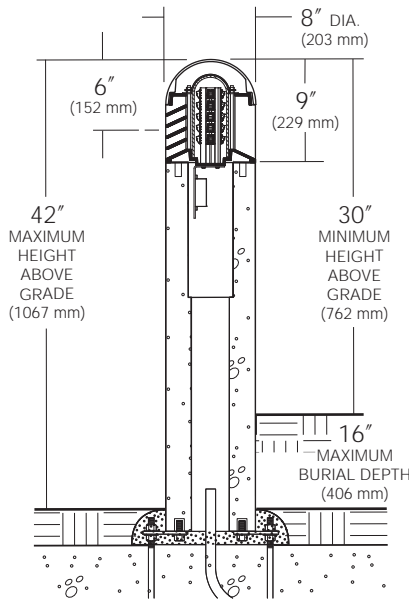

**BASE PLAN
VRB
CONCRETE SHAFT**

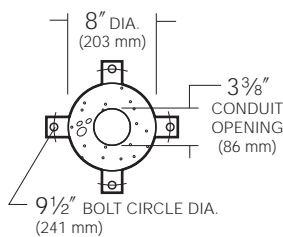

Domed Top Cap: Aluminum die-cast secured to louvers by concealed allen screws in keyhole slots. For relamping access, allen screws shall not require complete removal.

Louvers: One-piece, sand-cast with horizontal and vertical blades. Horizontal louvers shall provide 210° of downlighting with source cutoff above horizontal. Vertical louvers shall provide 150° of non-cutoff lighting. Horizontal louver blades shall have a 1 3/4" depth with a 65° upward pitch from horizontal. Vertical louver blades shall have a 1 3/4" depth with a 30° spacing. Louver assembly shall be secured to shaft by four internal tie rods.

Lamp Enclosure: One-piece tempered molded glass with internal flutes and full gasketing at bottom edge.

Fixture Head: Allows flow-through ventilation around and above the lamp enclosure.

Electronic Module: All electrical components are either UL or ETL recognized, mounted on a single plate and factory prewired with quick disconnect plugs. Driver is rated for -40°F starting and has a 0-10V dimming interface for multi-level illumination options.

Optical Module: Each LED equipped with a directional optic for maximum beam angle projecting through louver stack spacings. LED boards to be mounted to an anodized inter-locking heat sink extrusion. (Type I) two 5-LED boards for a total of 10-LED. (Type III) three 5-LED boards for a total of 15-LED. (Type V) four 5-LED boards for a total of 20-LED. Available in 3500K and 5100K color temperatures.

Anchor Bolts: Four 3/8" x 10" + 2" zinc plated L-hooks, each with two nuts, washers and a rigid pressed board template.

Material: Cement shall conform to current specifications for "Portland Cement." ASTM C150, Type I or II. Aggregates shall meet current requirements of "Specifications for Concrete Aggregates," ASTM C33. Water shall be clean and free from deleterious amounts of silt, oil, acids, alkalis or organic materials. Wire for reinforcement shall conform to ASTM A185. Steel for lugs and plates shall conform to ASTM A36, or A283 grade D.

Surface: Medium sand-blasted with anti-graffiti sealer. Available colors: Charcoal, Brown, Natural Gray or White, integral in concrete mix.

Cure and Strength: Allows for completion of the hydration process, and result in a 28 day compressive strength of not less than 4,500 psi.

Manufacture: Fiberglass molds used to insure uniform parts. Mold parting lines may be slightly visible in finished parts.

Anchorage: Four steel mounting tabs for installation on four 1/2" x 10" + 2" zinc electroplated L-hook anchor bolts. Each anchor bolt is supplied with two nuts, two washers, and a rigid pressed board template.

Shipment: Palletized with adequate hold-downs to prevent load movement in transit.

Finish: TGIC thermoset polyester powder coat paint, 2.5 mil nominal thickness, applied over a titanated zirconium conversion coating; 2500 hour salt spray test endurance rating. Standard colors are Black, Dark Bronze, Light Gray, Stealth Gray™, Platinum Silver, or White. Custom colors are available.

CAUTION: Fixtures must be grounded in accordance with national, state and/or local codes. Failure to do so may result in serious personal injury.

Listings and Ratings

UL, or ETL to UL Standards 1598 & 8750 ¹	IP46 Rated	25C Ambient
---	------------	-------------

¹ Suitable for wet locations

KIM LIGHTING RESERVES THE RIGHT TO CHANGE SPECIFICATIONS WITHOUT NOTICE.



Type:

Job:

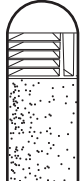

Standard Features

<p>Fixture</p>	<p>Cat. No. VRB2C Dual Function, Concrete Shaft, Domed Top</p>																
<p>Electrical Module LED = Light Emitting Diode</p>	<p>Cat. Nos. for LED Electrical Modules available:</p> <div style="display: flex; justify-content: space-around;"> <div style="text-align: center;"> <p>xL</p> <p>Source:</p> <p><input type="checkbox"/> 10L = 10 LED (IES Type I)</p> <p><input type="checkbox"/> 15L = 15 LED (IES Type III)</p> <p><input type="checkbox"/> 20L = 20 LED (IES Type V)</p> </div> <div style="text-align: center;"> <p>xK</p> <p>Color Temperature:</p> <p><input type="checkbox"/> 3K = 3500K</p> <p><input type="checkbox"/> 5K = 5100K</p> </div> <div style="text-align: center;"> <p>x</p> <p>Voltage:</p> <p><input type="checkbox"/> UV</p> <p>Universal Voltage shall range from 120V-277V</p> </div> </div> <table border="1" style="width: 100%; border-collapse: collapse; margin-top: 10px;"> <thead> <tr> <th style="width: 25%;">FITTURE</th> <th style="width: 25%;">TOTAL SYSTEM WATTS</th> <th style="width: 25%;">VOLT</th> <th style="width: 25%;">OPERATING AMPS</th> </tr> </thead> <tbody> <tr> <td>VRB2C – 10 LED</td> <td style="text-align: center;">12</td> <td style="text-align: center;">120 / 208 / 240 / 277</td> <td style="text-align: center;">.10 / .05 / .05 / .04</td> </tr> <tr> <td>VRB2C – 15 LED</td> <td style="text-align: center;">18</td> <td style="text-align: center;">120 / 208 / 240 / 277</td> <td style="text-align: center;">.15 / .09 / .08 / .07</td> </tr> <tr> <td>VRB2C – 20 LED</td> <td style="text-align: center;">24</td> <td style="text-align: center;">120 / 208 / 240 / 277</td> <td style="text-align: center;">.20 / .12 / .10 / .09</td> </tr> </tbody> </table>	FITTURE	TOTAL SYSTEM WATTS	VOLT	OPERATING AMPS	VRB2C – 10 LED	12	120 / 208 / 240 / 277	.10 / .05 / .05 / .04	VRB2C – 15 LED	18	120 / 208 / 240 / 277	.15 / .09 / .08 / .07	VRB2C – 20 LED	24	120 / 208 / 240 / 277	.20 / .12 / .10 / .09
FITTURE	TOTAL SYSTEM WATTS	VOLT	OPERATING AMPS														
VRB2C – 10 LED	12	120 / 208 / 240 / 277	.10 / .05 / .05 / .04														
VRB2C – 15 LED	18	120 / 208 / 240 / 277	.15 / .09 / .08 / .07														
VRB2C – 20 LED	24	120 / 208 / 240 / 277	.20 / .12 / .10 / .09														
<p>Finish TGIC thermoset polyester powder coat paint applied over a titanated zirconium conversion coating on fixture top cap. Concrete shaft surface color is integral in concrete mix. Available in any combination of paint and concrete finishes listed at right.</p>	<p>Top Cap Color: Black Dark Bronze Light Gray Stealth Gray™ Platinum Silver White Custom Color¹ Cat. No.: <input type="checkbox"/> BL <input type="checkbox"/> DB <input type="checkbox"/> LG <input type="checkbox"/> SG <input type="checkbox"/> PS <input type="checkbox"/> WH <input type="checkbox"/> CC</p> <p>Concrete Shaft Color: Brown Charcoal Natural Gray White Cat. No.: <input type="checkbox"/> BR-C <input type="checkbox"/> CH-C <input type="checkbox"/> NG-C <input type="checkbox"/> WH-C</p> <p>NOTE: Black and Dark Bronze colors will produce slightly less louver brightness than Light Gray or White.</p> <p>¹ Custom colors subject to additional charges, minimum quantities and extended lead times. Available on fixture head only. Consult representative. Custom color description: _____</p>																