

Type:
Job:
Catalog number:

Approvals:

/	/	/	/	/
Mtg. Fixture	Electrical Module	Finish	Options	Structural Options
See page 2			See pages 3-4	
			See pages 5-7	

Select pole from Kim's Arms and Poles Selection Guide. If pole is provided by others indicate O.D. for arm fitting.

Date:
Page: 1 of 8

Specifications

STS-LED

60 Light Emitting Diodes
Total Max System Watts = 73W
Maximum Weight = 45 lbs.

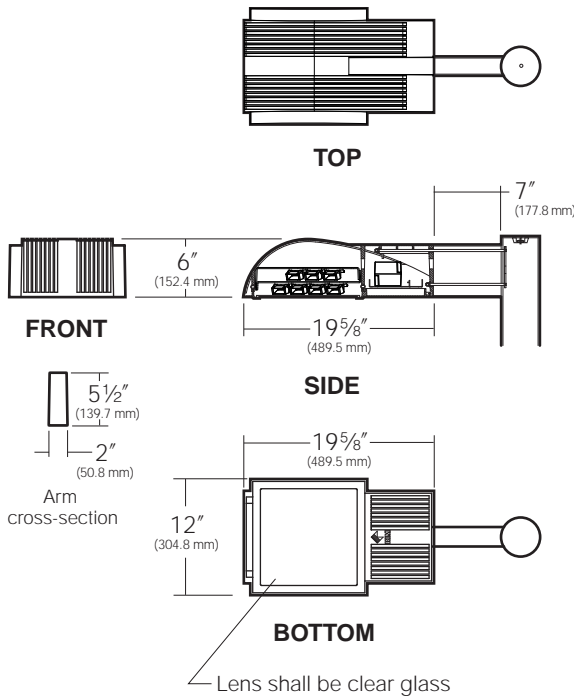

Housing: One-piece die-cast, low copper (<0.6% Cu) aluminum alloy with integral cooling fins on top surfaces above the optical chamber and electrical compartment. A solid barrier wall separates the optical and electrical compartments, with gasketed wire penetrations. A double-thick wall with gussets is provided on the support arm mounting end. All hardware is stainless steel.

Lens Frame: One-piece die-cast, low copper (<0.6% Cu) aluminum alloy with a 1" minimum thickness around the gasket flange for rigidity. Integral hinges with stainless steel pins provide no-tool mounting and removal from the housing. Two stainless steel thumb-latches are recessed into the front corners, concealed from normal view. Lens frame seals against the housing by a one-piece extruded silicone gasket with vulcanized end closure. Clear 3/16" thick tempered flat glass is retained in the frame by eight clips with full silicone gasketing around the perimeter.

Electronic Driver Module: One-piece die-cast, low copper (<0.6% Cu) aluminum alloy with integral cooling ribs over exposed bottom surface. Integral hinges and slide latch with stainless steel hardware provides no-tool mounting and removal from housing. Module includes a driver, thermal control device and surge protector. All electronic components are UL and CSA recognized and mounted directly to the driver tray for maximum heat dissipation. Driver is rated for -40°F starting and has a 0-10V dimming interface for multi-level illumination option.

Optical Module: Precision, replaceable MicroEmitters are positioned to achieve directional control toward desired task. Secondary MicroEmitters surround the module to redirect light downward. No fasteners are placed on the reflective surface. The entire EmitterDeck fastens to the housing as a one-piece module.

Support Arm: One-piece extruded aluminum with internal bolt guides. Luminaire-to-pole attachment is by internal draw bolts, and includes a pole reinforcing plate with wire strain relief. For mounting to round poles, arm is circular cut for precise mating to the pole diameter.

Finish/Color: Finish is Super TGIC thermoset polyester powder coat paint, 2.5 mil nominal thickness, applied over a titanated zirconium conversion coating; A.S.T.M. 2500 hour salt spray test endurance rating. Standard colors are Black, Dark Bronze, Light Gray, Stealth Gray™, Platinum Silver, or White. Custom colors are available.

Warranty: Kim Lighting warrants Structural LED products ("Product(s)") sold by Kim Lighting to be free from defects in material and workmanship for (i) a period of five (5) years for metal parts, (ii) a period of ten (10) years for exterior housing paint finish(s), (iii) a period of six (6) years for LED Light Engines (MicroEmitters) and, (iv) a period of five (5) years for LED power components (LED Driver, LifeShield™ device, Surge Protector), from the date of sale of such goods to the buyer as specified in Kim Lighting shipment documents for each product.

CAUTION: Fixtures must be grounded in accordance with national, state and/or local electrical codes. Failure to do so may result in serious personal injury.

Listings and Ratings

ETL to UL 1598' Standards	IP66 Rated	CE	25°C Ambient
Full Cut Off ² (flat Glass Lens Only)		Cutoff (Convex Glass Lens Only)	

¹Suitable for wet locations

²Dark Sky Compliant

KIM LIGHTING RESERVES THE RIGHT TO CHANGE SPECIFICATIONS WITHOUT NOTICE



U.S. Patents D439,695; D440,704;
D440,705; D441,130; D465,302S

Type:

Job:

Page: 2 of 8

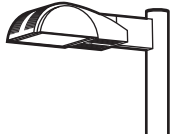

Standard Features

Mounting

3SY is available for round poles only.

Plan View:

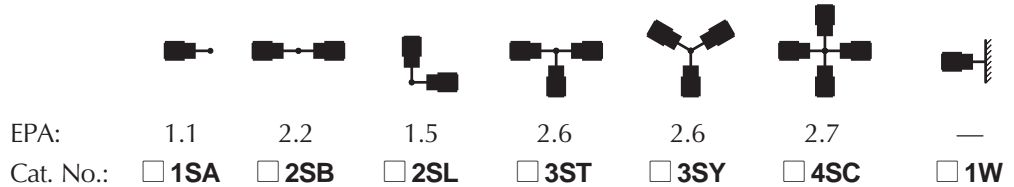

Fixture

Cat. No. designates **STS-led** fixture and optic.

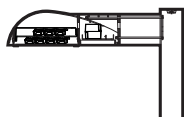

Flat Lens



Light Distribution:

Distribution:

- 2 = Type II Full Cutoff
- 3 = Type III Full Cutoff
- 4 = Type IV Full Cutoff
- 5 = Type V Square Full Cutoff
- L = Type L Left Full Cutoff
- R = Type R Right Full Cutoff



Type II



Type III



Type IV
Forward
Throw



Type V
Square



Type R
Right



Type L
Left

Electrical Module

Cat. Nos. for Electrical Modules available:

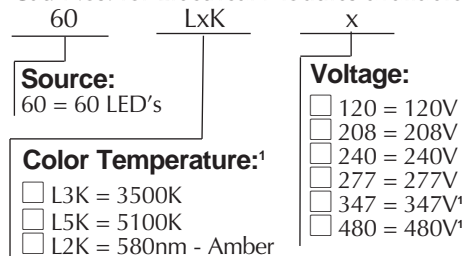

¹4300K and 6500K are also available on an "Engineered-to-Order" (ETO) basis.

²Due to current unavailability of 347V and 480V drivers, specification of these voltages may feature an integral step-down transformer.

Fixture	Total System Watts	Volt	Operating Amps
STS-Small	73	120	0.61
STS-Small	73	208	0.35
STS-Small	73	240	0.30
STS-Small	73	277	0.26
STS-Small	73	347	0.21
STS-Small	73	480	0.15

Finish

Super TGIC powder coat paint over titanated zirconium conversion coating.

Color: Black Dark Bronze Light Gray Stealth Gray™ Platinum Silver White Custom Color¹
Cat. No.: **BL** **DB** **LG** **SG** **PS** **WH** **CC**

¹Custom colors subject to additional charges, minimum quantities and extended lead times. Consult representative. Custom color description: _____

Type:

Job:

Page: 3 of 8



Optional Features

Wall Mounting

Cat. No. **1W**

Select from Mounting on page 2.

Modified support arm with side access to allow field splices within the arm, for poured concrete walls only. Fixture is mounted to wall using one 3/8"-16 external bolt and one 3/8" draw bolt threaded into the wall embedment bracket. Aluminum bearing plate provided to cover junction box, finished to match fixture. The wall embedment bracket (included with all wall mounted luminaires) provides 3/8"-16 bolt receptacles welded in a galvanized re-bar cage for casting into poured-in-place concrete walls. Bolt receptacles receive fixture attachment bolts.

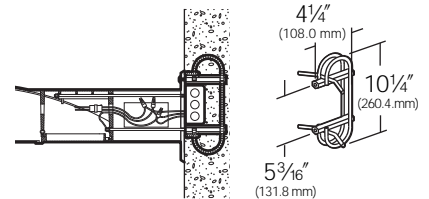

Wall mount using wall embedment bracket - J-box in wall (by others)

Photocell Control

Cat. No. (See chart on right)
 No Option

Fixture supplied with an internal photocell with the sensor on the housing side wall. For multiple-fixture pole mountings, one fixture has a photocell to operate the others.

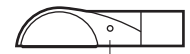

Photocell Sensor

Cat. No.	Line Volts:	Mounting Configuration
<input type="checkbox"/> A-30	120V	
<input type="checkbox"/> A-31	208V	- Fixture with Photocell Sensor
<input type="checkbox"/> A-32	240V	
<input type="checkbox"/> A-33	277V	
<input type="checkbox"/> A-35	347V	
<input type="checkbox"/> A-34	480V	No fixture wattage limit.

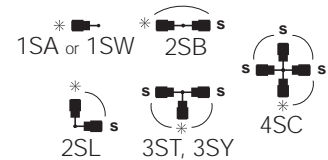

Dimming Controls

The Structural LED driver is a 0-10V dimming interface, allowing 0-100% illumination output when synchronized with a control and dimming system, provided by others. Kim Lighting is working with several control system manufacturers to develop a variety of proven turnkey solutions to meet any application's need. Kim Lighting will advise availability of complete control packages, and even two-way monitoring systems, once they have been tested and exceed Kim's high quality standards.

Convex Glass Lens

Cat. No. **CGL**
 No Option

The 3/16" thick clear convex tempered glass lens replaces the standard flat glass lens. Gives increased lens presence and provides a subtle improvement in uniformity where pole spacing is extreme. Increases effectiveness of houseside shielding.



2 1/8" (54.0 mm)
Convex Glass Lens

Polycarbonate Lens

Cat. No. **LS**
 No Option

One-piece vacuum formed, clear, UV stabilized convex polycarbonate, fully gasketed, replacing the standard tempered glass lens.

CAUTION: Use only when vandalism is anticipated to be high. Useful life is limited by UV discoloration from sunlight and metal halide lamps.



Polycarbonate Lens

Horizontal Slipfitter Mount

Cat. No. **HSF**
 No Option

Replaces standard mounting arm with a slipfitter which allows fixture to be mounted to a horizontal pole davit-arm with 2" pipe-size mounting end (2 3/8" O.D.). Cast aluminum slipfitter with set screws providing ±5° vertical fixture adjustment. Bolts to housing from inside the electrical compartment using mounting holes for the standard support arm. Davit-arm must be field drilled at a set screw location to insure against fixture rotation. Finished to match fixture.

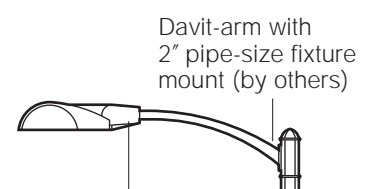

Davit-arm with 2" pipe-size fixture mount (by others)
Horizontal Slipfitter Mount by Kim

Type:

Job:

Page: 4 of 8



Optional Features

Special Options for Street Lighting

- Cat. No. **AF**
 No Option

Air Filter: Allows for ventilation through the optical chamber, filtering all air particles above 500 microns. Multi-layer disc assembly mounted on solid wall between optical and ballast compartments.

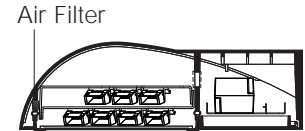

Vertical Slipfitter Mounts

- Cat. No. **(See chart on right)**
 No Option

For Standard Fixtures: Allows fixture with standard support arm to be mounted to steel poles having a steel 2" pipe-size tenon (2 3/8" O.D. x 4 1/2" min. length). 4" round or square cast aluminum with flush cap, secured to pole tenon by four 3/8" stainless steel set point allen screws. Finished to match fixture and arm.

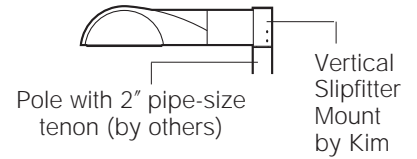

For existing pole installation or for use with poles provided by others.

- | | |
|------------------------|---|
| Mounting Configuration | Cat. No. |
| 1SA - single arm mount | <input type="checkbox"/> VSF-1SA |
| 2SB - 2 at 180° | <input type="checkbox"/> VSF-2SB |
| 2SL - 2 at 90° | <input type="checkbox"/> VSF-2SL |
| 3ST - 3 at 90° | <input type="checkbox"/> VSF-3ST |
| 3SY - 3 at 120° | <input type="checkbox"/> VSF-3SY |
| 4SC - 4 at 90° | <input type="checkbox"/> VSF-4SC |

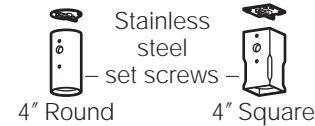

- | |
|--|
| Cat. No. |
| <input type="checkbox"/> SVSF-1SA |
| <input type="checkbox"/> SVSF-2SB |
| <input type="checkbox"/> SVSF-2SL |
| <input type="checkbox"/> SVSF-3ST |
| <input type="checkbox"/> SVSF-4SC |

For Fixtures with Structural Options: Allows fixture with structural options to be mounted to steel poles having a steel 2" pipe-size tenon (2 3/8" O.D. x 4 1/2" min. length). 4" round or square extruded aluminum with internal cast aluminum reinforcement, flush cap, secured to pole tenon by four 3/8" stainless steel set point allen screws. Finished to match fixture and arm.

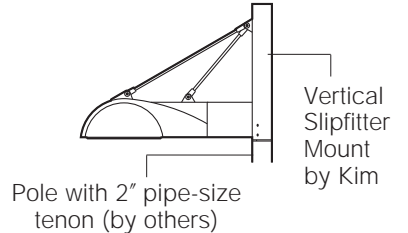

- | | |
|------------------------|--|
| Mounting Configuration | Cat. No. |
| 1SA - single arm mount | <input type="checkbox"/> STRF-1SA |
| 2SB - 2 at 180° | <input type="checkbox"/> STRF-2SB |
| 2SL - 2 at 90° | <input type="checkbox"/> STRF-2SL |
| 3ST - 3 at 90° | <input type="checkbox"/> STRF-3ST |
| 3SY - 3 at 120° | <input type="checkbox"/> STRF-3SY |
| 4SC - 4 at 90° | <input type="checkbox"/> STRF-4SC |

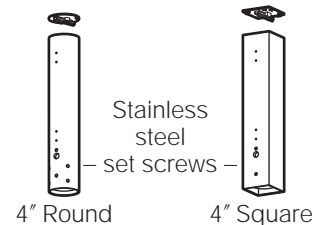







- | |
|--|
| Cat. No. |
| <input type="checkbox"/> STSF-1SA |
| <input type="checkbox"/> STSF-2SB |
| <input type="checkbox"/> STSF-2SL |
| <input type="checkbox"/> STSF-3ST |
| <input type="checkbox"/> STSF-4SC |

NOTE: Not available for **GS** Gusset.

Support Arm:

NOTE: Refer to Kim's Arms and Poles Selection Guide for complete details.

Optional Support Arm **cannot be used with #13 Pole Mounted Structural Option.**

Arm Cat. No.:	AA02	AA04	AA06	AA08	AA10	AA12
Mounting:						
	Swept Solid Arm	Swept Hollow Arm	Upsweep Solid Arm	Upsweep Hollow Arm	Uplift Adjustable Aluminum Arm	Uplift Adjustable Stainless Steel Arm
1SA	EPA for fixture	1.0	0.9	1.1	1.0	1.3
2SB		2.0	1.8	2.2	2.0	2.6
2SL	and arm:	1.4	1.3	1.5	1.4	1.8
3ST		2.4	2.2	2.6	2.4	3.1
3SY		2.4	2.2	2.6	2.4	3.1
4SC		2.5	2.3	2.7	2.5	3.5

Type:

Job:



Optional Features

Fusing

Cat. No. (see right)
 No Option

Line Volts: 120V 208V 240V 277V 347V 480V
Cat. No.: SF DF DF SF SF DF

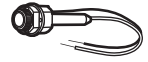

Single Fuse

Pole Mounted Structural Options

Cat. No. (See right)
 No Option

TS - Single Tension Rod: Rod has die-cast aluminum clevis which fasten to die-cast aluminum cleats. Fixture cleat is factory mounted, and includes a silicone gasket. Pole cleat is field mounted, and is circular cut for precise mating to round poles. Rod diameter is .406". All fasteners are blackened stainless steel. All Kim poles are pre-drilled to accept fixture arm and tension rod cleat.

Cat. No.

TSP Structural option rod and clevis detail is finished to match fixture.

TSN Structural option rod is stainless steel with nickel plated clevis.

Mounting: 1SA 2SB 2SL 3ST 3SY 4SC
EPA: 1.2 2.4 1.6 2.8 2.8 2.9

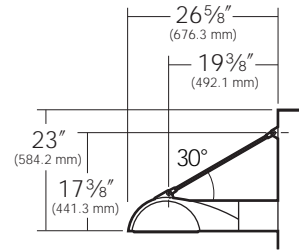

TD - Double Tension Rods: Rods have die-cast aluminum end brackets which fasten to die-cast aluminum cleats. Fixture cleats are factory mounted, and include silicone gaskets. Pole cleat is field mounted, and is circular cut for precise mating to round poles. Rod diameter is .406". All fasteners are blackened stainless steel. All Kim poles are predrilled to accept fixture arm and tension rod cleats.

Cat. No.

TDP Structural option rod and clevis details are finished to match fixture.

TDN Structural option rods are stainless steel with nickel plated clevis.

Mounting: 1SA 2SB 2SL 3ST 3SY 4SC
EPA: 1.25 2.5 1.65 2.9 2.9 3.0

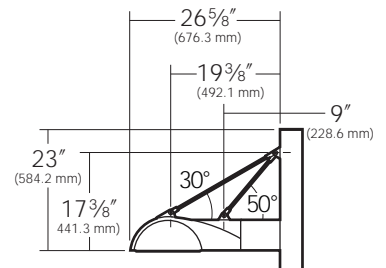

TR - Truss: Cast aluminum truss is fastened to die-cast aluminum cleats. Fixture cleat is factory mounted, and includes a silicone gasket. Pole cleats are field mounted, and are circular cut for precise mating to round poles. Truss members are 3/4" square. All fasteners are blackened stainless steel. All Kim poles are pre-drilled to accept fixture arm and truss cleats.

Cat. No.

TR Structural option is finished to match fixture.

Mounting: 1SA 2SB 2SL 3ST 3SY 4SC
EPA: 1.4 2.8 1.9 3.3 3.3 3.4

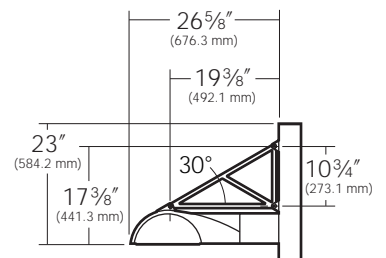

Type:

Job:



Optional Features

Pole Mounted Structural Options

(Continued from page 7)

GS - Gusset: Cast aluminum gusset is field mounted to the fixture arm, and circular cut for precise mating to round poles.

Cat. No.

GS Structural option is finished to match fixture and arm.

Mounting: 1SA 2SB 2SL 3ST 3SY 4SC
EPA: 1.25 2.5 1.7 2.95 2.95 3.05

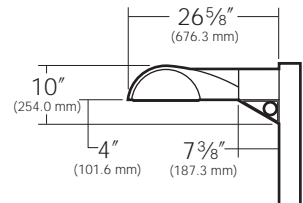

Wall Mounted Structural Options

Cat. No. (See right)

No Option

TS - Single Tension Rod: Rod has die-cast end brackets which fasten to die-cast aluminum cleats. Fixture cleat is factory mounted, and includes a silicone gasket. Wall cleat is mounted with two 10-32 stainless steel screws (anchors in wall by others), and includes an aluminum bearing plate. Rod diameter is .406". All fasteners are blackened stainless steel. The wall embedment bracket provides 3/8"-16 bolt receptacles welded in a galvanized re-bar cage for casting into poured-in-place concrete walls. Bolt receptacles receive standard draw bolts inside fixture arm, or any 3/8"-16 bolt (by others).

Cat. No.

TSP-W Structural option rod and clevis detail is finished to match fixture.

TSN-W Structural option rod is stainless steel with nickel plated clevis.

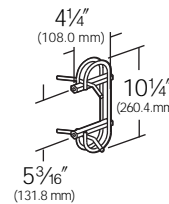
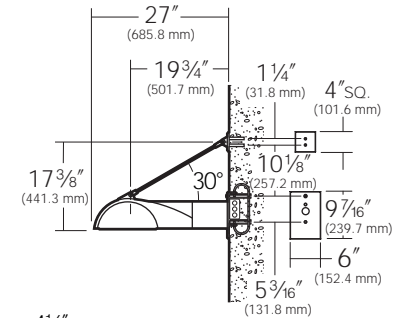

Wall embedment bracket - J-box in wall (by others)

TD - Double Tension Rods: Rods have die-cast end brackets which fasten to die-cast aluminum cleats. Fixture cleats are factory mounted, and include silicone gaskets. Wall cleat is mounted with two 10-32 stainless steel screws (anchors in wall by others), and includes an aluminum bearing plate. Rod diameter is .406". All fasteners are blackened stainless steel. The wall embedment bracket provides 3/8"-16 bolt receptacles welded in a galvanized re-bar cage for casting into poured-in-place concrete walls. Bolt receptacles receive standard draw bolts inside fixture arm, or any 3/8"-16 bolt (by others).

Cat. No.

TDP-W Structural option rod and clevis details are finished to match fixture.

TDN-W Structural option rods are stainless steel with nickel plated clevis.

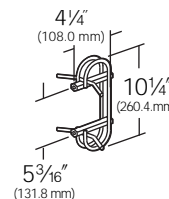
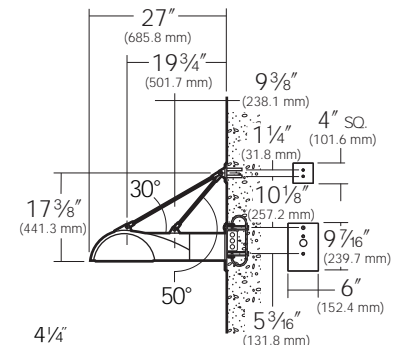

Wall embedment bracket - J-box in wall (by others)

Wall Mounted Structural Options continued on next page.

Type:

Job:



Optional Features

Wall Mounted Structural Options

(Continued from page 6)

TR - Truss: Cast aluminum truss is fastened to die-cast aluminum cleats. Fixture cleat is factory mounted, and includes a silicone gasket. Top wall cleat is mounted with two 10-32 stainless steel screws (anchors in wall by others), and includes an aluminum bearing plate. Lower wall cleat is factory mounted to an extended wall bearing plate. Truss members are 3/4" square. All fasteners are blackened stainless steel. The wall embedment bracket provides 3/8"-16 bolt receptacles welded in a galvanized re-bar cage for casting into poured-in-place concrete walls. Bolt receptacles receive standard draw bolts inside fixture arm, or any 3/8"-16 bolt (by others).

Cat. No.

TR-W Structural option is finished to match fixture.

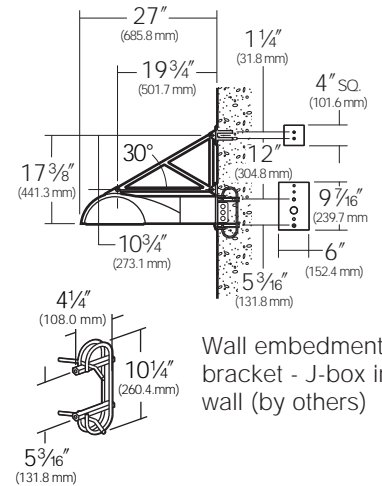

Wall embedment bracket - J-box in wall (by others)

GS - Gusset: Cast aluminum gusset is field mounted to the fixture arm, and finished to match fixture and arm. An extended wall bearing plate provides visual backing for the gusset. The wall embedment bracket provides 3/8"-16 bolt receptacles welded in a galvanized re-bar cage for casting into poured-in-place concrete walls. Bolt receptacles receive standard draw bolts inside fixture arm, or any 3/8"-16 bolt (by others).

Cat. No.

GS-W Structural option is finished to match fixture.

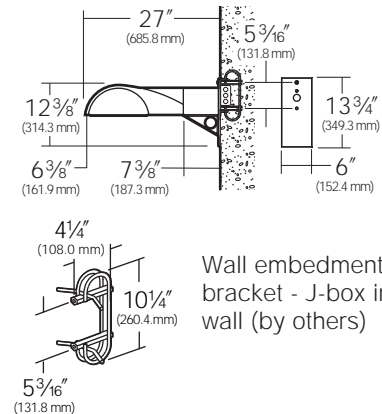

Wall embedment bracket - J-box in wall (by others)

NOTE: Luminaires are designed for down facing mounting only - do not mount inverted, in up facing position.

Type:
Job:

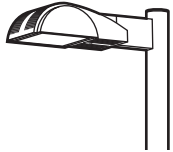

Lumen Performance Charts

NOTES:

- Lumen loss stabilization is a result of Kim Lighting's MicroEmitter™ luminaires exclusive LifeShield™ Protection System and Dual Heat Management.
- The LifeShield™ Protection System will lower the current to the LEDs significantly if the luminaire is exposed to direct heat (sun) or excessive abnormal conditions.
- Luminaire Lumen Loss assumptions are based on LM-80 results and an actual outdoor product testing based upon 5100K CCT, 350mA drive current. 25°C/77°F tab ambient and cathode temperature at 85°C/185°F. Assumptions past 6,000 hours are interpolated.
- Cathode temperature baseline is at 85°C/185°F. If cathode temperature increases during ambient changes and abnormal environment conditions, % of rated lumens will slightly decrease.
- Outdoor ambient temperatures are assumed SITU average by geographic region.
- As Solid State Lighting technology and thermal management systems continually advance, lumen loss projections are subject to improvement.

