



Type:
Job:
Fixture Catalog number:

/	/	
Fixture	Electrical Module See page 3	Optional Features See pages 4-5

Approvals:

Date:
Page: 1 of 8

Specifications

PGL7-LED

60 Light Emitting Diodes
Total Operating System Watts = 73W
Maximum Weight = 19lbs

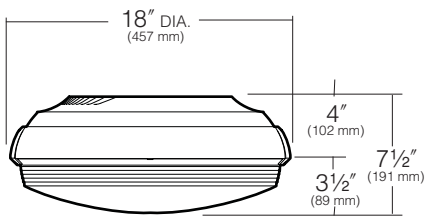

Fixture with Standard Acrylic Refractor

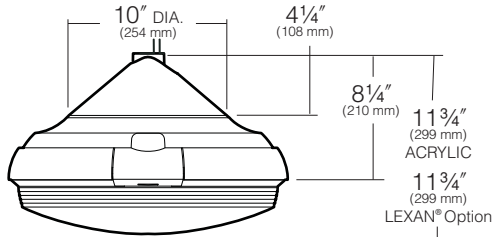

Fixture with Optional Balanced Pendant J-Box and Bird Shroud (PB2)

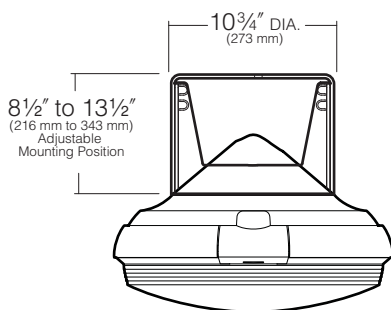

Fixture with Optional Trunnion Mount (TB2)

Speed Mount: Electro-zinc plated steel for mounting to standard 4" junction box or mud-box. Fixture hangs from hooks to free both hands to make field wire connections. Allows tool-free fixture mounting to junction box, with integral anti-theft lock.

Electrical Housing: Die-cast, low copper (<0.6% Cu) aluminum alloy for direct mounting to the Kim Speed Mount. Wire entries are sealed by a silicone grommet. Integral latches (2) are die-cast aluminum with stainless steel springs and stainless steel hangers for the refractor.

Refractor: Standard refractor is one-piece injection molded acrylic, .125" minimum wall thickness. Optional refractor is one-piece injection molded UV stablized Lexan, .125" minimum wall thickness. The prisms around the perimeter refract the spill light off the MicroEmitters upward to eliminate the cave effect. Refractor attaches to electrical housing with (2) no-tool quick release latches, with one latch captive as a hinge. Perimeter is fully sealed with a one-piece extruded silicone gasket, with the ends fused together to form a continuous piece, sealing the refractor to the electrical housing, and providing an IP66 fixture rating.

EmitterDeck : Precision injection molded, high specular reflectors are positioned to achieve directional control toward desired task. The entire assembly fastens to the housing as a one-piece module and features wiring quick-disconnects for easy upgrade replacement.

Electronic Module: All electrical components are UL recognized and mounted directly to the electrical housing for maximum heat dissipation. Module includes a driver, thermal control device and surge protector. A step-down transformer within the housing may be used for 347V and 480V systems.

Finish: Standard finish on fixture electrical housing, optional PB2 and TB2, is **(PS)** Platinum Silver. Platinum Silver is Powdura® TGIC powder coat paint. All other colors are Super TGIC powder coat paint. Optional white (WH) and custom colors available.

Warranty: Kim Lighting warrants PGL7 LED products ("Product(s)") sold by Kim Lighting to be free from defects in material and workmanship for (i) a period of five (5) years for metal parts, (ii) a period of ten (10) years for exterior housing paint finish(s), (iii) a period of six (6) years for LED Light Engines (MicroEmitters) and, (iv) a period of five (5) years for LED power components (LED Driver, LifeShield™ device, Surge Protector), from the date of sale of such goods to the buyer as specified in Kim Lighting shipment documents for each product.

CAUTION: Fixtures must be grounded in accordance with national, state and/or local electrical codes. Failure to do so may result in serious personal injury.

Listings and Ratings

CSA listed to UL 1598 standards ¹	IP66 Rated	40°C Ambient
--	------------	--------------

¹Suitable for wet locations.

KIM LIGHTING RESERVES THE RIGHT TO CHANGE SPECIFICATIONS WITHOUT NOTICE.



Patent Pending

Type:

Job:

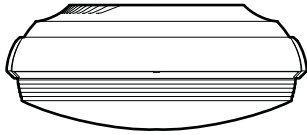

Standard Features

Fixture

Cat. No. designates **PGL** fixture with Wide or Narrow optical distribution

Wide = 70° Peak Intensity Angle

Narrow = 57.5° Peak Intensity Angle

Cat. Nos. for optical distributions

PGL71
Type V
Square

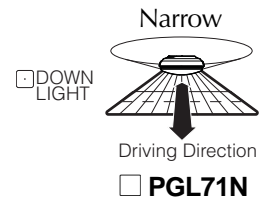
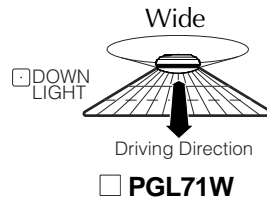

PGL72
Type I



PGL73
Type I

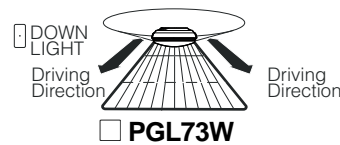

PGL74
Type III

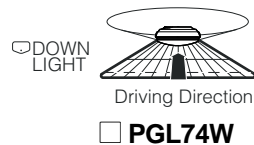

PGL75
Type III



PGL76
Type L



PGL77
Type R



Type:

Job:

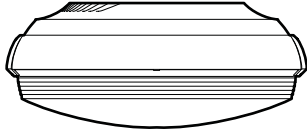

Standard Features

Electrical Module

LxK = Light Emitting Diodes

Lamp Line
 Type Volts

60LxK xxx

PGL7-LED

60 Light Emitting Diodes
 Total Operating System
 Watts = 75W

NOTE: PGL7 LED system
 employs Nichia's SSL product.
 Part number: NS6x183
 (NS6L183 H3,NS6W183 H3)

Cat. Nos. for Electrical Modules available:

60L	xK	xxx
Source: 60L=60 LEDs		Voltage:
Color Temperature:¹		<input type="checkbox"/> 120 = 120V
<input type="checkbox"/> 3K = 3500K		<input type="checkbox"/> 208 = 208V
<input type="checkbox"/> 5K = 5100K		<input type="checkbox"/> 240 = 240V
<input type="checkbox"/> 2K = 580nm Amber		<input type="checkbox"/> 277 = 277V
		<input type="checkbox"/> 347 = 347V ²
		<input type="checkbox"/> 480 = 480V ²

¹4300K and 6500K are also available on an "Engineered to Order" (ETO) basis.

²Due to current unavailability of 347V and 480V drivers, specification of these voltages may feature an integral step down transformer.

Fixture	Total System Watts	Volt	Operating Amps
PGL7	73	120	0.61
PGL7	73	208	0.35
PGL7	73	240	0.30
PGL7	73	277	0.26
PGL7	73	347	0.21
PGL7	73	480	0.15

Type:

Job:

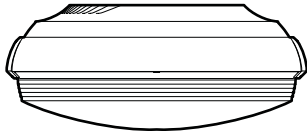

Optional Features

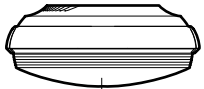
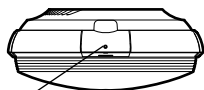
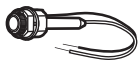
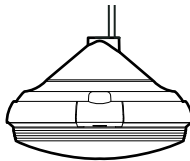
<p>Finish Platinum Silver is Powdura® TGIC powder coat paint. All other colors are Super TGIC powder coat paint.</p>	<p>Color: Platinum Silver White Custom Color¹ (Standard) Cat. No.: <input type="checkbox"/> PS <input type="checkbox"/> WH <input type="checkbox"/> CC ¹Custom colors subject to additional charges, minimum quantities and extended lead times. Consult representative. Custom color description: _____</p>
<p>Semi-Opal Refractor Lens Cat. No. <input type="checkbox"/> ASOL= Acrylic <input type="checkbox"/> LSOL= Lexan® <input type="checkbox"/> No Option</p>	<p>The semi-opal refractor lens is a one-piece injection molded acrylic or Lexan lens, .125" minimum wall thickness. The lens option softens the light output and reduces glare from direct views of the optical system. The semi-opal lens decreases the luminaire efficiency, and has a different index of refraction than the standard, clear acrylic or clear polycarbonate. As a result, moderately altering beam angles and candela.</p>  <p>Semi-Opal Refractor Lens</p>
<p>Tamper-Resistant Latches Cat. No. <input type="checkbox"/> TS <input type="checkbox"/> No Option</p>	<p>Stainless steel captive hex socket (Allen) shoulder screws secure latches in locked position.</p>  <p>Tamper-Resistant Latch</p>
<p>Fusing Cat. No. (see right) <input type="checkbox"/> No Option</p>	<p>High temperature fuse holders factory installed inside the fixture housing. Fuse included.</p> <p>Line Volts: 120V 208V 240V 277V 347V 480V Cat. No.: <input type="checkbox"/> SF <input type="checkbox"/> DF <input type="checkbox"/> DF <input type="checkbox"/> SF <input type="checkbox"/> SF <input type="checkbox"/> DF</p>  <p>Single Fuse</p>
<p>Balanced Pendant J-Box and Bird Shroud Cat. No. <input type="checkbox"/> PB2PS Platinum Silver (Std PGL7 finish) <input type="checkbox"/> PB2WH White <input type="checkbox"/> PB2CC Custom Color <input type="checkbox"/> No Option</p>	<p>Die-cast aluminum. Offset 3/4" NPT pendant entry to balance fixture in free-swinging installation. Conduit pipe provided by others. The Kim Speed Mount is furnished for fixture attachment to the PB2. This option is shipped separate from fixture.</p> <p>Custom Color _____</p>  <p>Balanced Pendant J-Box and Bird Shroud</p>

Type:

Job:

Page: 5 of 8

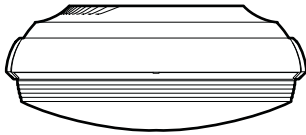

Optional Features

Trunnion Mount

- Cat. No. **TB2PS**
 Platinum Silver
 (Std PGL7 finish)
- TB2WH**
 White
- TB2CC**
 Custom Color
- No Option**

One-piece cast aluminum fixture mount, utilizes the standard Kim speed mount for fixture attachment, and also serves as a junction box for field wire connections. Top of fixture mount casting has 1/2" NPT to receive conduit from ceiling J-box. (Ceiling J-box and conduit to fixture by others.) Upper trunnion section is 1 1/2" aluminum bar with adjustable mounting positions in 1" increments. Suspends fixture from 8 1/2" to 13 1/2" below the ceiling, as measured to the fixture top.

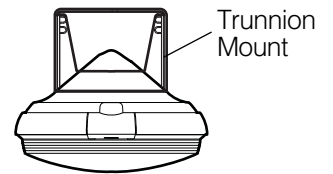

Custom Color: _____

Perimeter Shield Lens

- Cat. No. **PSL**
 No Option

The lens rim shall be shielded 180° to reduce uplight or light trespass illumination by employing a high heat color spray around the house side portion of the lens.

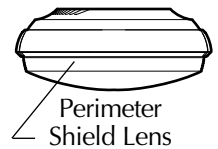

NOTE: PGL74W, PGL74N and PGL75W, PGL75N only.

Type:
 Job:

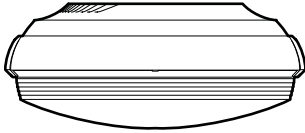

Optional Features

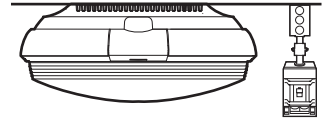
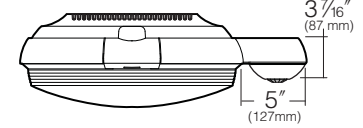
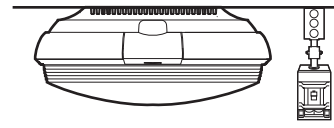
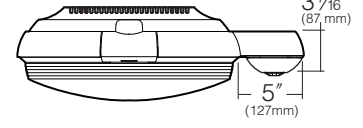
<p>Smart Control Cat. No. <input type="checkbox"/> SC1 <input type="checkbox"/> No Option</p> <p>Option requires a signal from a master satellite or remote occupancy sensor device to operate dimming capabilities.</p>	<p>SC¹ Provides the most economical low voltage method of switching lighting levels based on occupancy within a space. SC1 is equipped with a relay and fixed resistor to allow 50% dimming; PGL7 driver is a 0 10V dimming interface. Wire leads extending out the top of the luminaire for twisted pair wiring connection to the occupancy sensor. The occupancy sensor device is a remote install, typically mounted to a J box. Wire leads exiting the luminaire distance is 8". junction box and occupancy sensor by others.</p>	 <p>Remote by others</p>
<p>Smart Control Cat. No. <input type="checkbox"/> SC2¹ <input type="checkbox"/> No Option</p>	<p>SC2¹ The occupancy sensor device and aluminum enclosure is factory installed onto the electrical housing. SC2 is equipped with a power pack, fixed resistor and occupancy sensor to allow 50% dimming; PGL7 driver is a 0 10V dimming interface. Wire leads extending out the top of the luminaire for twisted pair wiring connection to the occupancy sensor. For master SC2 relay communication, a set of secondary detection wiring extends out the top of the luminaire for satellite relaying, up to 10 units. Occupancy sensor provided.</p> <p>NOTE: See page 7 for sensor technical details.</p>	
<p>Smart Control Cat. No. <input type="checkbox"/> SC3 <input type="checkbox"/> No Option</p> <p>Option requires a signal from a master satellite or remote occupancy sensor device to operate dimming capabilities.</p>	<p>SC3² Provides an advanced method of switching lighting levels based on occupancy within a space. SC3 is equipped with a control module and an antenna to provide 0 100% dimming; PGL7 driver is a 0 10V dimming interface. An RF relay device is included in the luminaire for wireless communication (by others). For master relaying from occupancy control, connection can be wireless or twisted pair wiring. The SC3 control module can provide satellite relaying up to 300' maximum distance. Wire leads exiting the luminaire distance is 8". junction box and occupancy sensor by others. Control panel by others.</p>	 <p>Remote by others</p>
<p>Smart Control Cat. No. <input type="checkbox"/> SC4¹ <input type="checkbox"/> No Option</p>	<p>SC4^{1,2} Provides a state of the art method of switching lighting levels based on occupancy within a space. The occupancy sensor device and aluminum enclosure is factory installed onto the electrical housing. SC4 is equipped with a control module, power pack and an antenna to provide 0 100% dimming; PGL7 driver is a 0 10V dimming interface. An RF relay device is included in the luminaire for wireless communication. The SC4 control module can provide satellite relaying up to 300' maximum distance. Occupancy sensor provided. Control panel by others..</p> <p>NOTE: See page 7 for sensor technical details.</p>	

¹SC2 and SC4 occupancy sensor (Model No. OMN11RLRP) is a product of Hubbell Building Automation, a division of Hubbell Lighting Inc. UL and cUL listed with a 5 year warranty.
²SC3 and SC4 wireless components are third party products, and will carry the manufacturer's commissioning, technical support service, and warranty policy.
 All sensor options can be configured for on/off switching configuration. Contact Kim Lighting for "engineered to order" inquiries.

Type:
 Job:

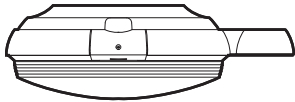

Occupancy Sensor Features (SC2 and SC4 only)

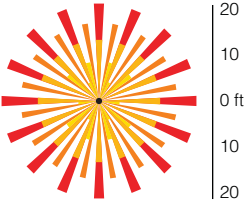
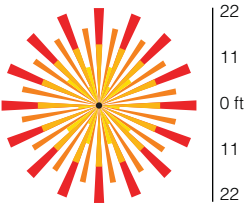
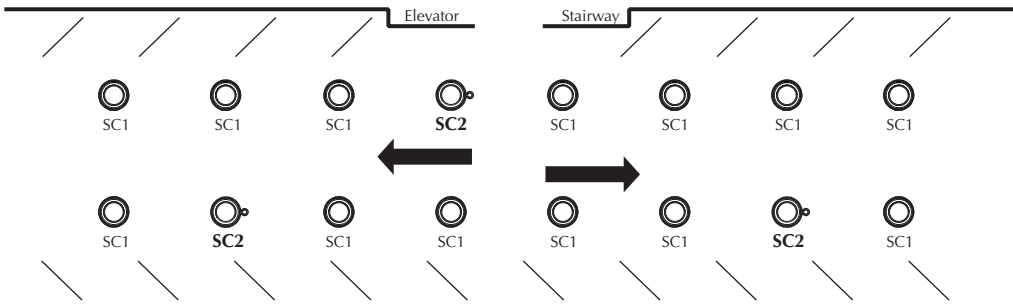
Bi-Level Illumination:	The 24VDC relay is attached to one PGL7 LED driver for 50% output.
Typical Sensor Coverage: 8' Mounting Height 20' Radius Detection	 <p>Top View</p> <p>NOTE: Senses Infrared (IF) energy radiated by human presence. Objects in the path of the sensors line of sight can disrupt coverage.</p>
Typical Sensor Coverage: 9' Mounting Height 22' Radius Detection	 <p>Top View</p> <p>NOTE: Senses Infrared (IF) energy radiated by human presence. Objects in the path of the sensors line of sight can disrupt coverage.</p>
Time Delay	Fully adjustable time delay of 8 seconds-30 minutes including override capability. Factory time delay set at 30 minutes. Test Mode: 8 seconds (for an easy check at installation).
Ambient Light Detection (photocell mode)	Fully adjustable ambient light level override (0 footcandles to 100 footcandles/bypass). Factory ambient light level set at 5 footcandles (5 lux). NOTE: Ambient light detection measures both artificial and natural daylight light levels. Ambient light detection is based on Illuminance measurements.
Sensitivity	Employs Hubbell Building Automation's IntelliDAPT technology. Fully self-adjusting passive infrared thresholds, automatic false-on/false-off corrections and self-adjusting timer.
Master to Satellite Example. Enclosed Structure SC2 Master to SC1 Satellite	 <p>Diagram not to scale. Reference only.</p> <p>NOTE: Satellite coverage may vary due to mounting height. Always consult the manufacturer's technical data for coverage limitations and restrictions.</p>

Type:

Job:

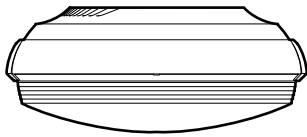

Lumen Performance Charts

NOTES:

1. Lumen loss stabilization is a result of Kim Lighting's MicroEmitter™ luminaires exclusive LifeShield™ Protection System and Dual Heat Management.
2. The LifeShield™ Protection System will lower the current to the LEDs significantly if the luminaire is exposed to direct heat (sun) or excessive abnormal conditions.
3. Luminaire Lumen Loss assumptions are based on LM 80 results and an actual outdoor product testing based upon 5100K CCT, 350mA drive current. 25°C/77°F tab ambient and cathode temperature at 85°C/185°F. Assumptions past 6,000 hours are interpolated.
4. Cathode temperature baseline is at 85°C/185°F. If cathode temperature increases during ambient changes and abnormal environment conditions, % of rated lumens will slightly decrease.
5. Outdoor ambient temperatures are assumed SITU average by geographic region.
6. As Solid State Lighting technology and thermal management systems continually advance, lumen loss projections are subject to improvement.

Luminaire Lumen Loss by Hours of Operation

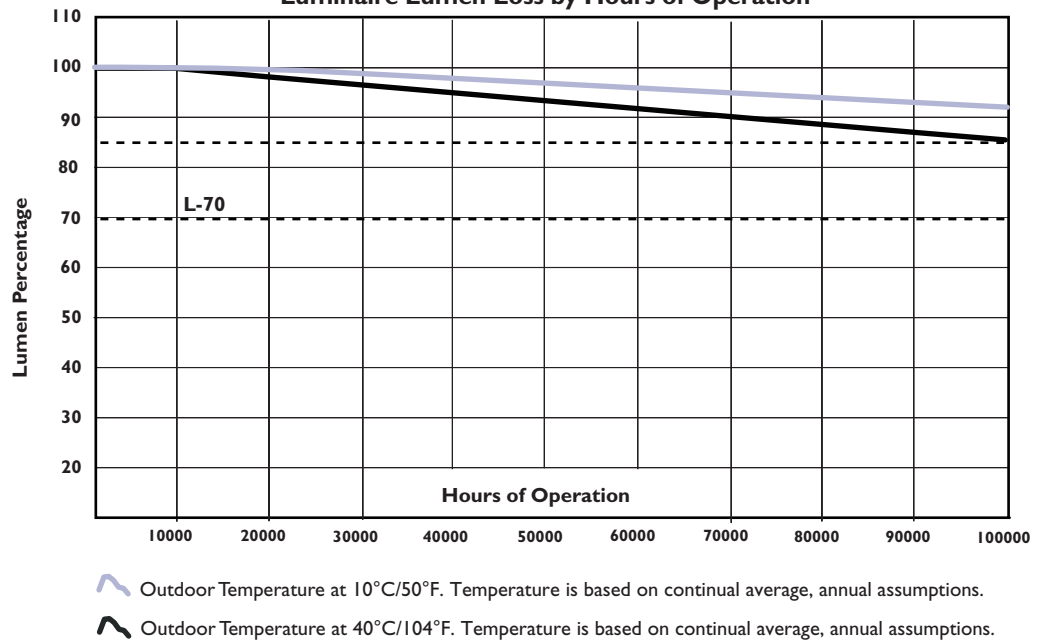

Luminaire Output at Outdoor Ambient Temperatures

