



**KIM LIGHTING**

# LTV50 Series Composite Housing Accent or Wall Wash

Lightvault®

revision 8/15/11 • ltv50.pdf

**Type:**

**Job:**

**Catalog number:**

Fixture	Optics	Lamp Mode	Option - order assembled with fixture
_____ / _____	_____ / _____	_____ / _____	_____ / _____
See page 2		See page 3	

**Fixture Options:**

Ordered separately from fixture  
See page 3 - 4

**Approvals:**

**Date:**  
**Page: 1 of 6**

## Specifications

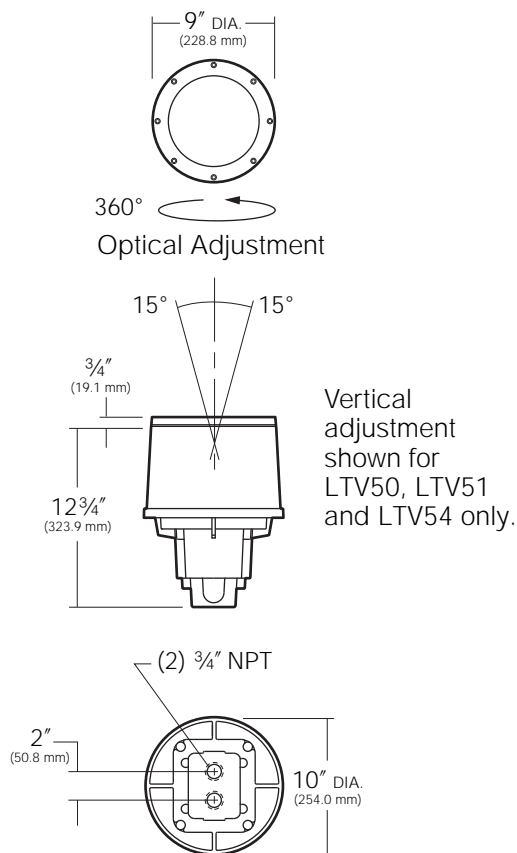

**Lens Ring:** One-piece cast bronze, natural finish. (Optional standard stainless steel lens ring is also available.) Eight captive 5/16" blackened stainless steel hex-socket cap screws.

**Lens:** Clear tempered borosilicate glass, 1/4" thick, flush with lens ring, slightly crowned.

**Lens Gasket:** One-piece molded silicone, U-channel wraps completely around lens flange.

**Composite Housing:** High temperature, compression molded, fiberglass impregnated, 3/16" min. wall composite. Charcoal gray. No top lip to trap dirt and moisture. Solid brass knurled inserts molded-in to receive lens ring screws. Separate splice and ballast compartments, individual cast aluminum internal covers, with silicone gaskets. Two 3/4" NPT in bottom, 24 cu in. splice area. Modular reverse draft design (top dia. smaller than bottom), body and ballast modules epoxy bonded.

**Optical System: SP and NF** - Spot or narrow flood spun aluminum reflector, specular Alzak®, black Duranodic® arc tube glare shield on SP only. (G12 base socket option available.) **PR** - for PAR38 reflector lamps, or PAR36 and AR111 12V lamps in LTV54 only. All sockets 4KV medium base. All optical systems yoke mounted, 360° rotation, ±15° vertical adjustment, locking screws, black anodized gimbal ring. **WW** - one-piece hydroformed reflector, specular Alzak®, 360° rotation and screw locks, Wall Wash distribution, medium base 4KV socket for H.I.D. lamps. (G12 base socket option available.) Mini-can socket for halogen lamps. **PL** - GX24q-3 universal socket is provided for fluorescent.

**Electrical Module:** High power factor ballast, -20°F starting, factory mounted to gasketed compartment cover, LTV50 and LTV52 only.

**Wiring:** Anti-siphon barriers on all wiring to and from ballast compartment. All components wire linked for ground, quick disconnect for removal of optical system.

**Drive-over Durability:** When installed in concrete (see page 5), fixture will withstand drive-over by vehicles weighing up to 5,500 lb.

**See page 6 for safety and warranty information.**



Hubbell  
Lighting, Inc.

U.S. PATENTS D410,295 AND D411,640

### Listings and Ratings

UL cUL 1598 <sup>1</sup>	IP68 Rated	CE	25C Ambient
--------------------------	------------	----	-------------

<sup>1</sup>Suitable for wet recessed

KIM LIGHTING RESERVES THE RIGHT TO CHANGE SPECIFICATIONS WITHOUT NOTICE.



Type:



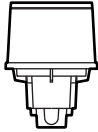



Job:



**Standard Features**

70 PMH 120  
 Lamp Watts    Lamp Type    Line Volts

PMH = Pulse Start Metal Halide  
 HPS = High Pressure Sodium  
 HAL = Halogen  
 LV = Low Voltage  
 PL = Compact Fluorescent

Fixture	Optics	Lamp Mode
Cat. No. <input type="checkbox"/> <b>LTV50</b> HID Accent	<input type="checkbox"/> <b>SP</b> Spot <input type="checkbox"/> <b>NF</b> Narrow Flood  Yoke mounted reflector and medium base socket for ED-17 HID lamp. <input type="checkbox"/> <b>PR</b> PAR Lamp  Yoke mounted medium base socket for PAR38 HID reflector lamp.	Pulse Start Metal Halide <input type="checkbox"/> <b>50PMH120</b> <sup>1</sup> <input type="checkbox"/> <b>50PMH208</b> <sup>1</sup> <input type="checkbox"/> <b>50PMH240</b> <sup>1</sup> <input type="checkbox"/> <b>50PMH277</b> <sup>1</sup> <input type="checkbox"/> <b>50PMH347</b> <sup>1</sup> <input type="checkbox"/> <b>70PMH120</b> <input type="checkbox"/> <b>70PMH208</b> <input type="checkbox"/> <b>70PMH240</b> <input type="checkbox"/> <b>70PMH277</b> <input type="checkbox"/> <b>70PMH347</b> High Pressure Sodium <input type="checkbox"/> <b>50HPS120</b> <sup>1</sup> <input type="checkbox"/> <b>50HPS208</b> <sup>1</sup> <input type="checkbox"/> <b>50HPS240</b> <sup>1</sup> <input type="checkbox"/> <b>50HPS277</b> <sup>1</sup> <input type="checkbox"/> <b>50HPS347</b> <sup>1</sup> <input type="checkbox"/> <b>70HPS120</b> <sup>1</sup> <input type="checkbox"/> <b>70HPS208</b> <sup>1</sup> <input type="checkbox"/> <b>70HPS240</b> <sup>1</sup> <input type="checkbox"/> <b>70HPS277</b> <sup>1</sup> <input type="checkbox"/> <b>70HPS347</b> <sup>1</sup> Compact Fluorescent <input type="checkbox"/> <b>32PL120</b> <sup>1</sup> <input type="checkbox"/> <b>32PL208</b> <sup>1</sup> <input type="checkbox"/> <b>32PL240</b> <sup>1</sup> <input type="checkbox"/> <b>32PL277</b> <sup>1</sup> <sup>1</sup> Not available for <b>PR</b> optics.
Cat. No. <input type="checkbox"/> <b>LTV51</b> Halogen Accent	<input type="checkbox"/> <b>PR</b> PAR Lamp  Yoke mounted medium base socket for PAR38 halogen reflector lamp.	<input type="checkbox"/> <b>120HAL120</b> 120W maximum, lower wattage lamps may be used.
Cat. No. <input type="checkbox"/> <b>LTV52</b> HID Wall Wash	<input type="checkbox"/> <b>WW</b> Wall Wash  Hydroformed reflector and medium base socket for ED-17 HID lamp.	Pulse Start Metal Halide <input type="checkbox"/> <b>50PMH120</b> <input type="checkbox"/> <b>50PMH208</b> <input type="checkbox"/> <b>50PMH240</b> <input type="checkbox"/> <b>50PMH277</b> <input type="checkbox"/> <b>70PMH120</b> <input type="checkbox"/> <b>70PMH208</b> <input type="checkbox"/> <b>70PMH240</b> <input type="checkbox"/> <b>70PMH277</b> <input type="checkbox"/> <b>70PMH347</b> High Pressure Sodium <input type="checkbox"/> <b>50HPS120</b> <input type="checkbox"/> <b>50HPS208</b> <input type="checkbox"/> <b>50HPS240</b> <input type="checkbox"/> <b>50HPS277</b> <input type="checkbox"/> <b>50HPS347</b> <input type="checkbox"/> <b>70HPS120</b> <input type="checkbox"/> <b>70HPS208</b> <input type="checkbox"/> <b>70HPS240</b> <input type="checkbox"/> <b>70HPS277</b> <input type="checkbox"/> <b>70HPS347</b> Compact Fluorescent <input type="checkbox"/> <b>26PL120</b> <input type="checkbox"/> <b>26PL208</b> <input type="checkbox"/> <b>26PL240</b> <input type="checkbox"/> <b>26PL277</b>
Cat. No. <input type="checkbox"/> <b>LTV53</b> Halogen Wall Wash	<input type="checkbox"/> <b>WW</b> Wall Wash  Hydroformed reflector and socket for T-4 Halogen mini-can lamp.	<input type="checkbox"/> <b>150HAL120</b> 150W maximum, lower wattage lamps may be used.
Cat. No. <input type="checkbox"/> <b>LTV54</b> Low Voltage Accent	<input type="checkbox"/> <b>PR</b> PAR Lamp  Yoke and slip-on wire tabs for PAR36 or AR111 12V lamp.	<input type="checkbox"/> <b>100LV120</b> <input type="checkbox"/> <b>100LV277</b> 12V lamps with 120V or 277V input to fixture. 100W maximum, lower wattage lamps may be used.



Type:

Job:

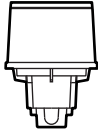

### Optional Features

<p><b>G12 Base Socket</b>          Cat. No. <input type="checkbox"/> <b>G12 socket</b>  <input type="checkbox"/> <b>No Option</b></p>	<p>Socket is available for 70W Pulse Start Metal Halide T-6 Bipin lamps.</p>
<p><b>Brushed Stainless Steel Lens Ring</b>          Cat. No. <input type="checkbox"/> <b>SS50</b>  <input type="checkbox"/> <b>SS50 (Assembled)</b>  <input type="checkbox"/> <b>No Option</b></p>	<p>One-piece standard brushed stainless steel replaces standard lens ring. Includes glass lens gasket and mounting screws.          May be ordered separately. To order assembled with fixture, add to fixture <b>Cat. No.</b> - Example: <b>LTV50/xx/xxxxxxx/SS50</b></p>
<p><b>Half Shield</b>          Cat. No. <input type="checkbox"/> <b>HS50</b>  <input type="checkbox"/> <b>No Option</b></p>	<p>Half shield lens ring for directional glare control toward the viewer. One-piece cast bronze, replaces standard lens ring. Includes glass lens gasket and mounting screws.</p>
<p><b>Rock Guard</b>          Cat. No. <input type="checkbox"/> <b>RG50</b>  <input type="checkbox"/> <b>No Option</b></p>	<p>Rock guard lens ring for lens protection in vandal prone areas. One-piece cast bronze, replaces standard lens ring. Includes glass lens gasket and mounting screws.  <b>CAUTION:</b> On LTV52, rock guard will cast severe shadows on the lighted surface with clear lamps. If rock guard is required, use coated lamps and estimate a 50% reduction in longitudinal light throw and intensity. Rock guard not recommended for LTV53 halogen wall wash fixtures.</p>
<p><b>Trim Ring</b>          Cat. No. <input type="checkbox"/> <b>TR50</b>  <input type="checkbox"/> <b>No Option</b></p>	<p>Trim ring for flush mounting of fixture in concrete pad or paving. Brass ring clamps to housing with stainless steel screw.</p>
<p><b>Grout Mask</b>          Cat. No. <input type="checkbox"/> <b>GM50</b>          TR50 Trim Ring Included  <input type="checkbox"/> <b>No Option</b></p>	<p>Grout mask for fixture support during concrete pour. Galvanized steel ring and rebar supports fixture when tied into paving rebar. 2" grout space provided for finishing up to fixture (see page 5).</p>

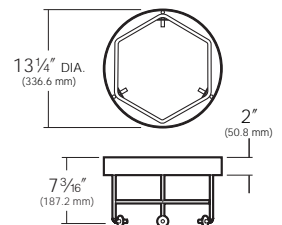
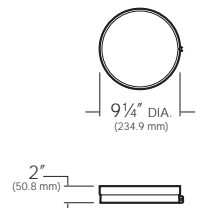
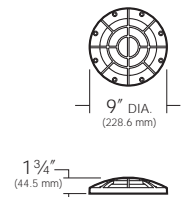
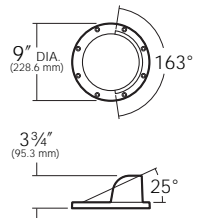
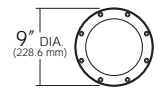



Type:

Job:

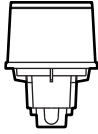

## Optional Features

### Lens Accessories

Cat. No. (See right)

No Option

**HL - Hex Cell Louver:** Constructed of hex cell aluminum louvers with a cell dimension of 1/4" W x 1/4" D, producing a 45° cutoff angle, mounted in a circular frame, finished in baked high-heat flat black. May be used in combination with colored lenses. Inserts behind lens into lens gasket.

Not for use in combination with **SL** spread or **PL** prismatic lenses.

Not for use with **WW** optics.

Cat. No.

**HL50** Hex Cell Louver



**PL - Prismatic Lens:** Softens lamp distribution. Best with flood lamps. Inserts behind lens into lens gasket.

Not for use in combination with **HL50** louver.

Not for use with **WW** optics.

Cat. No.

**PL50** Prismatic Lens



**SL - Spread Lens:** Creates an oval beam pattern. Best with spot lamps. Inserts behind lens into lens gasket.

Not for use in combination with **HL50** louver.

Not for use with **WW** optics.

Cat. No.

**SL50** Spread Lens





Type:

Job:

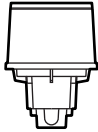

## Installation Recommendations

### Create a Buffer Zone

When fixtures are located in areas planted in ground cover or shrubbery, construct a buffer zone to prevent lens overgrowth and to create an edge for trimming. Elevate the fixtures for drainage and backfill with decorative rock. As the ground cover grows, the fixtures will look flush even though they are 2" to 4" above grade.

#### Advantages

- Prevents lens overgrowth.
- Provides a defined edge for trimming.
- Provides drainage away from the lens to maintain light output.
- Visually looks like a flush installation.

### Buffer Zone

Redwood or other material for edging.

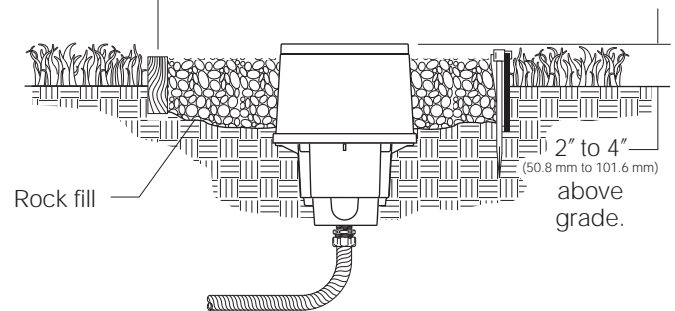

### Install in Concrete

For installations in ground cover, shrubbery or lawn areas, encase the fixture in concrete. This creates a buffer zone as described above with the additional advantage of greater fixture stability. Elevate the fixture 2" to 4" above grade, and slope the concrete away from the lens for drainage.

#### Advantages

- Cleaner, more stable installation, less susceptible to traffic and maintenance activity.
- Prevents lens overgrowth.
- Provides a defined edge for trimming.
- Provides drainage away from the lens to maintain light output.
- Visually looks like a flush installation.

### Concrete Installation

Concrete must have reinforcing rods to prevent cracking from fixture heat expansion.

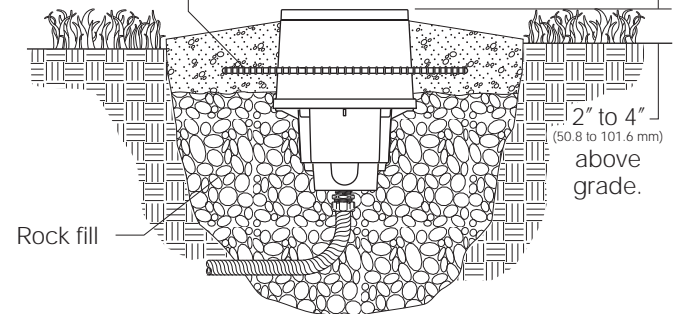

**NOTE:** Always use adequate rebar surrounding the fixture to prevent cracking of the concrete due to heat expansion.

### In Paved Areas

When in-grade luminaires are installed in paving, it is usually required that the lens frame be flush with finished grade. To make this installation easier, Kim offers an optional grout mask (page 3) to support the fixture at the proper height during the concrete pour. The grout mask is normally tied to the paving rebar for support.

#### Advantages

- Supports fixture at proper height during concrete pour.
- Provides 2" grout space for finishing.
- Easily adapts to any paving material; concrete, brick, stone, etc.
- Provides maximum drive-over durability.

### Paved Area Installation

Optional grout mask supports fixture during concrete pour.

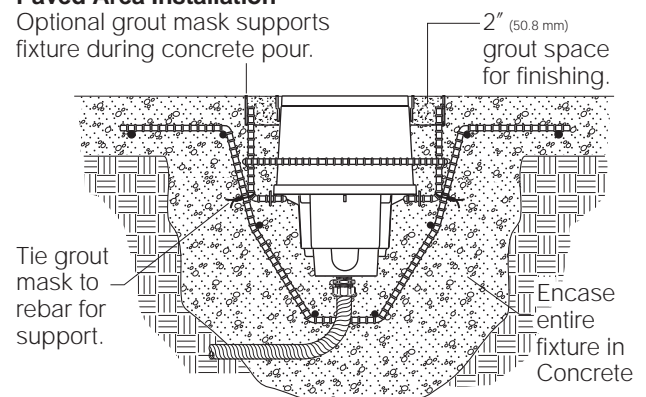

**NOTE:** See safety and warranty information on page 6.



Type:

Job:

Page: 6 of 6

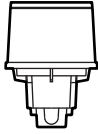

## Safety and Warranty Information

### Safety and Maintenance Warning

1. Fixtures must be grounded in accordance with national, state, and/or local codes. Failure to do so may result in serious personal injury.
2. Extreme caution should be taken when fixtures are used in paved areas. High temperature lenses can burn feet, hands or objects inadvertently placed on top of fixtures. If fixtures must be used in paved areas, locate them away from normal pedestrian traffic, and use the lowest wattage lamp possible.
3. It is recommended that all conduit entries be sealed with RTV silicone to maintain a clean, dry splice compartment.
4. To maintain light efficiency and prevent fixture overheating, lenses must be kept clean and free of dirt, dust, leaves, and trash.
5. Lightvault fixtures are not approved for any submersible installations including fountains, ponds, reflecting ponds or swimming pools.

### 25/7 Year Limited Warranty

When installed according to Kim Installation Instructions and accepted trade practices, the solid bronze trim rings on LTV Series Kim products are warranted for 25 years, and the composite housings are warranted for 7 years, from date of sale, against manufacturing defects and failure due to corrosion. All other fixture components (excluding lamps) are warranted to be free of defects in material and workmanship for 1 year from date of sale. During the warranty periods, with proof of purchase, Kim will repair or replace with the same or similar product, at Kim's option, without charge. Labor costs are the owner's responsibility and are excluded from this warranty. This warranty is void if the product is modified, tampered with, misapplied, poorly installed, improperly maintained or subjected to abnormal conditions.

Repair or replacement as provided under this warranty is the exclusive remedy of the purchaser. This warranty is in lieu of all other warranties, expressed or implied, including any implied warranty of fitness for the particular application. Kim Lighting shall not be liable to the purchaser for indirect or consequential damages.