



Type:
Job:
Ordering Example:

2B / AR3 / 250HPS277 / WH-P / AA05 /
Mounting Fixture Electrical Module Finish Options

Ordering Information

Always refer to the specific luminaire catalog, and the ordering information page within that catalog. Place the optional Architectural Arm catalog number as an "Option" following the Fixture catalog numbers.

Approvals:

Date:
Page: 1 of 3

Specifications

AA05
Large

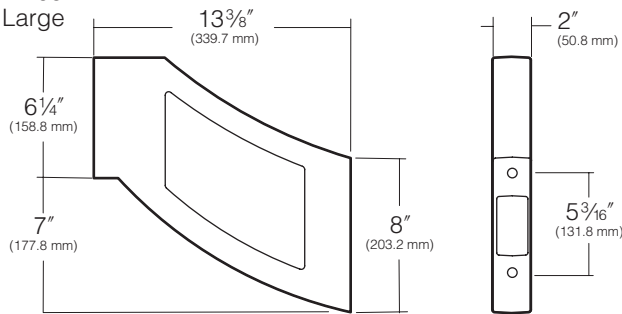

AA06
Small

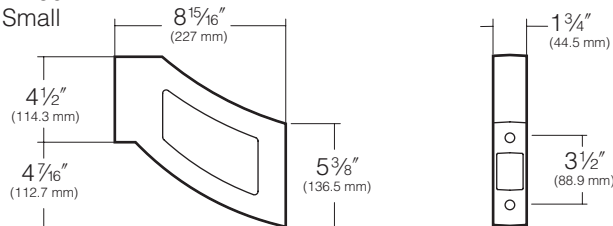

Arm: One-piece casting of 356 alloy, low-copper (<0.6% Cu) aluminum. Bottom of arm is open for access to mounting hardware and wiring, enclosed by a flush mounted cast aluminum cover retained by a single stainless steel screw. Attachment to pole is by concealed 3/8" stainless steel hex head bolts threaded into a pole backing plate located inside the pole. Pole backing plate is heavy gauge zinc plated steel, and includes a wire strain relief and ground connection. For round poles, arm is circular cut for the specific pole diameter. Arm-to-luminaire attachment is by concealed 3/8" galvanized rods threaded into the arm, projecting into the fixture where 3/8" nuts and washers secure the mounting.

Finish: Kim's premium Super TGIC thermoset polyester powder coat, 2.5 mil nominal thickness, applied over a titanated zirconium conversion coating. Arm color is always provided to match the selected fixture color.

























KIM LIGHTING RESERVES THE RIGHT TO CHANGE SPECIFICATIONS WITHOUT NOTICE.

Type:

Job:

Page: 2 of 3

Architectural Arm	Luminaire Type	Mounting Configurations					
AA05 EPA:	AR ET STL STX	 A	 B	 L	 T	 Y ¹	 C
		1.7	3.4	2.5	4.2	4.2	4.9
		2.2	4.4	3.0	4.8	4.6	5.4
		2.4	4.8	3.0	5.4	5.4	5.7
	3.3	6.6	4.3	7.6	7.6	7.9	
	CC/VL17 CC/VL21 CC/VL25 CC/VL29 AC21 AC27	 A	 B	 L	 T	 Y ¹	 C
		1.5	3.0	2.2	3.7	3.7	4.0
		1.8	3.6	2.8	4.6	4.6	5.1
		1.9	3.8	3.1	5.1	5.1	5.7
		2.2	4.4	3.7	5.9	5.9	6.6
		2.2	4.4	3.2	4.8	4.8	5.0
		2.9	5.8	3.8	6.3	6.3	6.7
	MX21	 A	 B	 L	 T		 C
		2.4	4.8	4.1	5.7	---	6.6
	AA06 EPA:	SAR SET STS	 A	 B	 L	 T	 Y ¹
1.0			2.0	1.5	2.5	2.5	3.0
1.2			2.4	1.7	2.9	2.7	3.2
1.1			2.2	1.5	2.6	2.6	2.7 Same as Standard Arm

Note: Y mounting configuration is available for round poles only.

Type:

Job:

Page: 3 of 3

Optional Features

Wall Mounting Cat. No. 1W

Mounting Plate: A cast mounting plate of 356 alloy, low-copper (<0.6% Cu) aluminum, is mounted to the wall with bolts (by others). Fixture and arm are mounted to a cast 356 alloy aluminum cover plate before attaching to the wall mounting plate. The fixture-arm-cover plate assembly is hooked to the wall mounting plate, and secured with stainless steel screws provided. After mounting to the wall, field splices are made at the opening in the cover plate, then covered by a cast 356 alloy aluminum plate that blends with the cover plate design. Complete fixture-arm-cover plate assembly can therefore be mounted before field splices are made. Cover plate is finished to match arm and fixture powder coat color.

CAUTION: Structural integrity of mounting plate attachment to wall is by others.

