

Structural™

F u l l C u t o f f L u m i n a i r e

70 - 1000 Watt

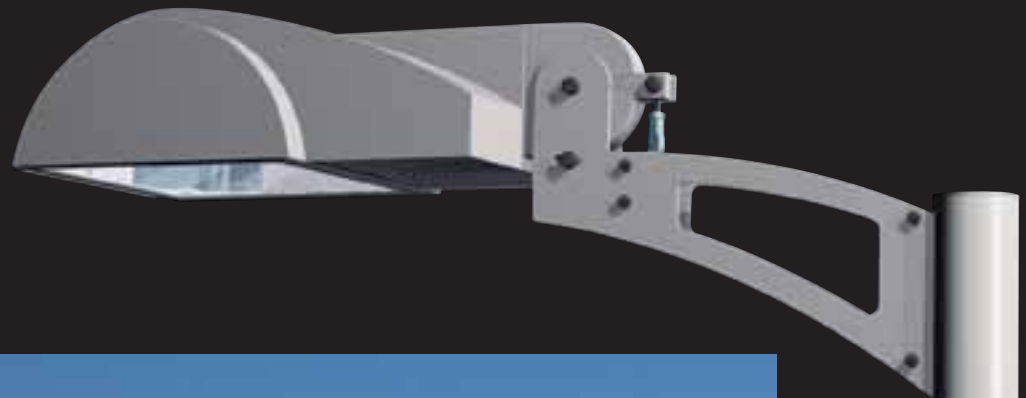

KIM LIGHTING

Structural™

Table of Contents

Relativity	2-3
Horizontal Lamp	4
Optical System Features	6
Mechanical Design Features	8
Installation and Maintenance	9
STX Ordering Information	12-13
STL Ordering Information	14-15
STS Ordering Information	16-17
Luminaire Specifications	18
Option Specifications	19
Pole Mounted and Wall Mount Option Specifications	22-25
Proportion Guide	27
Lamp and Electrical Guide	28-29



**SITE / AREA
PARKING STRUCTURE
ROADWAY
ARCHITECTURAL FLOOD
ACCENT
LANDSCAPE**

MAILING ADDRESS:
P.O. BOX 60080
CITY OF INDUSTRY, CA
91716-0080

BUSINESS ADDRESS:
16555 EAST GALE AVENUE
CITY OF INDUSTRY, CA 91745
U.S.A.

PHONE 626 / 968 - 5666
FAX 626 / 369 - 2695

ENTIRE CONTENTS
© COPYRIGHT 2010 KIM LIGHTING INC.
ALL RIGHTS RESERVED
REPRODUCTION IN WHOLE OR IN PART
WITHOUT PERMISSION IS STRICTLY PROHIBITED.
U.S. PATENTS D439,695, D440,704,
D440,705, D441,130 AND D465,302S

www.kimlighting.com

Star View.
compliant



**Hubbell
Lighting, Inc.**

Printed in U.S.A.
5505310288
Version 2.1 (10/10)

Structural™ represents a breakthrough concept. Never before has a Site / Area luminaire offered such versatility in complementing architectural design. Structural's elegant form is an orchestrated combination of simple shapes in a dynamic architectural luminaire. The addition of optional structural elements produces a beautiful enhancement to today's structurally expressive architecture. Functionally, Structural combines state-of-the-art optics, materials, and ergonomics to create glare free, low maintenance lighting solutions. The **STX** (1000W Structural) is available in HID lamp modes to 1000 watts. The **STL** (Large Structural) is available in HID lamp modes to 400 watts. The **STS** (Small Structural) is available to 175 watts, and is perfectly scaled for pathways and courtyards. When used together, they provide a logical scale transition from parking lot to building entrance.





Kim Lighting's Theory of Relativity

The Relationship of Outdoor Lighting to Site and Architecture



STX 1000W Structural™
STL Large Structural™



STS Small Structural™



VRB Vandal Resistant Bollard



LTV Lightvault®

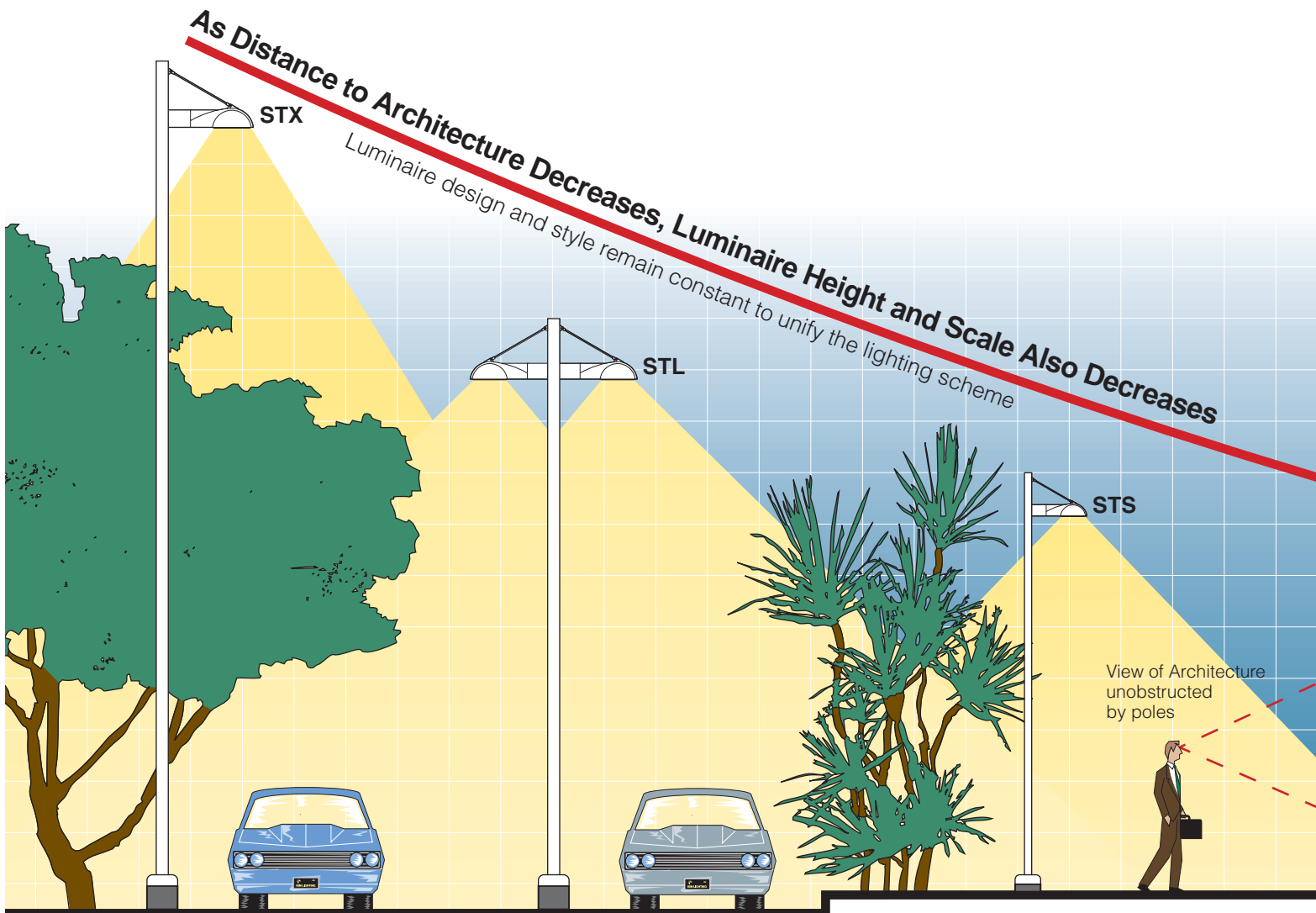

SITE / ROADWAY ZONE

Parking lots and roadways require luminaires on 20' - 40' poles to efficiently light these large areas. Therefore, this lighting becomes dominant and sets the design and style for all other lighting as you progress towards the building.

PEDESTRIAN ZONE

As you leave the parking lot and transition to pedestrian areas, poles should decrease in height to 10' - 16'. In addition, luminaires should decrease in scale, and can have more decorative features to be appreciated at the pedestrian level.



AFL Architectural Floodlight



LLF Low Level Floodlight



STS Small Structural™



WD Wall Director®

KIM LIGHTING'S THEORY OF RELATIVITY

The purpose of this guideline is to bring a cohesive look to outdoor lighting, maximizing lighting efficiency while preserving the architectural experience. Simply stated, the Kim Theory of Relativity says "Poles belong in parking lots. And, once you leave the parking lot, the outdoor lighting should become less and less conspicuous until it becomes an integral part of the architecture." In addition, the luminaire style and geometry should remain consistent. If this guideline is utilized, the outdoor lighting will enhance the site and architecture, bringing unity to the outdoor lighting scheme.

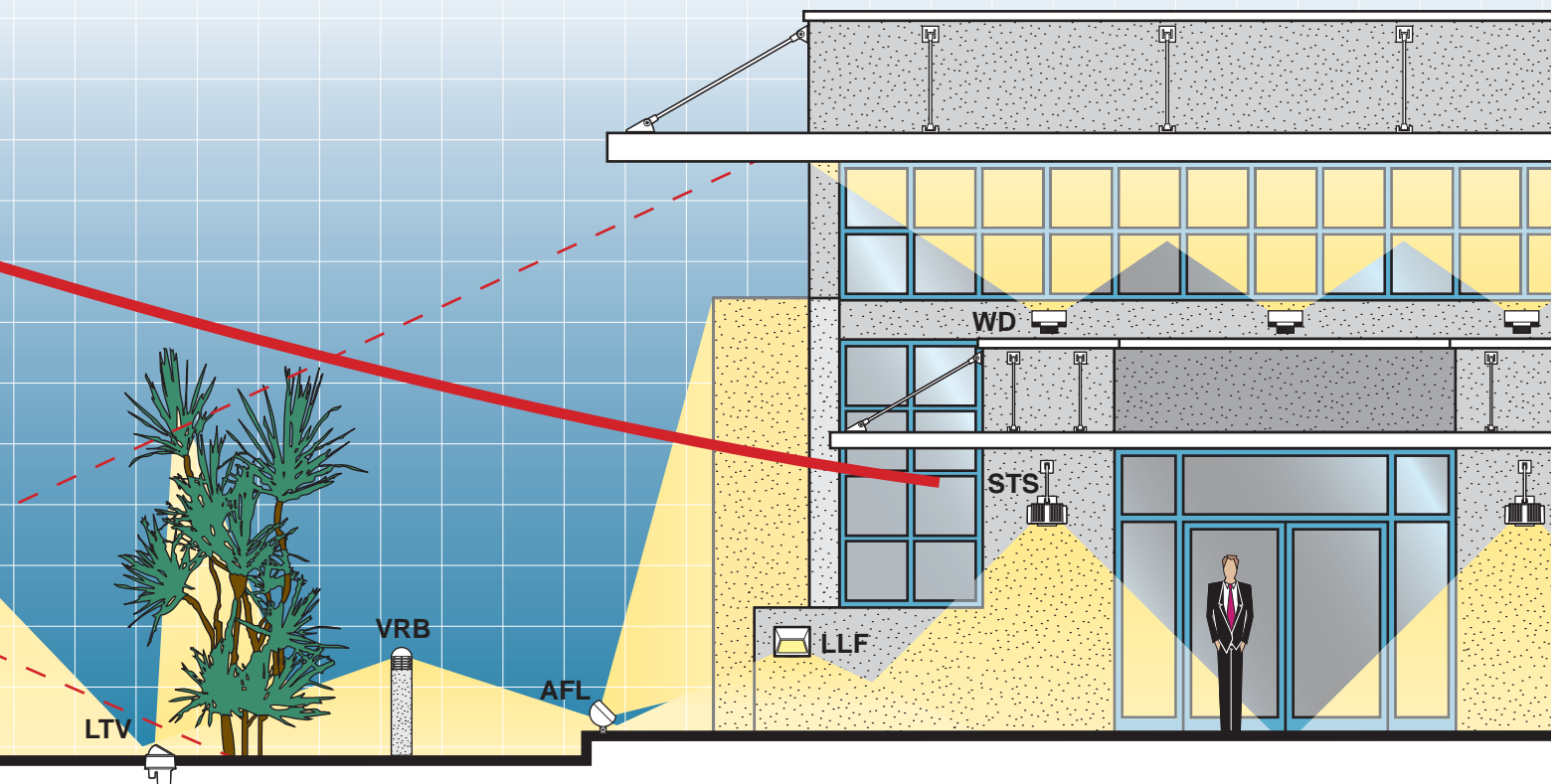

LANDSCAPE / PATH ZONE

Near the building, luminaires should begin to disappear, blending into the landscape and hardscape elements.

BUILDING / PERIMETER ZONE

No pole mounted luminaires should ever be used near the building, as they will dominate the architecture. The only exception would be the use of decorative luminaires to delineate entrances to the structure. Building mounted, architecturally compatible fixtures should be almost invisible.

Horizontal Lamp

See the **Kim Site / Roadway Optical Systems Catalog** for complete details and explanation of optical system features.

Horizontal Lamp

Available in **Type II, Type III, Type IV, and Type V Square** distributions, this flat lens system provides **full cutoff control** and very good uniformity.

Sealed optics and performance reflector technology allow this horizontal lamp optical system to maximize lamp output. An optional houseside shield is available for Types II, III, and IV distributions.

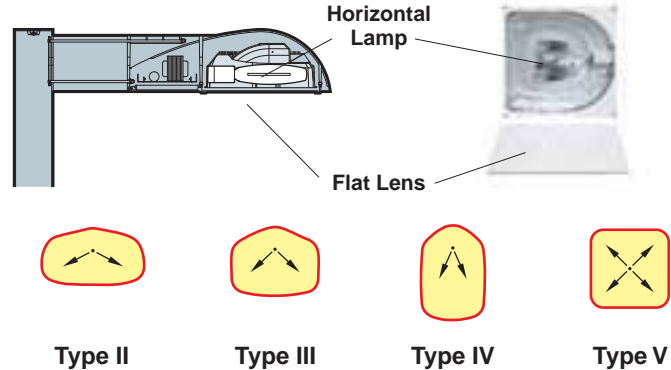

An **optional convex lens** offers increased lens presence, a subtle improvement in uniformity, and increased effectiveness of houseside shielding. Changes light distribution from Full Cutoff to Cutoff.

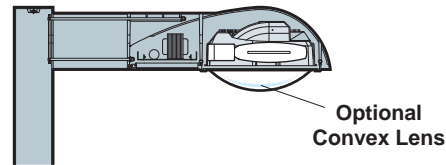

Full Cutoff

Structural™ luminaire utilizes a horizontal lamp orientation with a flat glass lens to produce full cutoff with zero light above 90° horizontal. In addition, the reflector system has been carefully engineered to provide maximum pole spacing with outstanding visual uniformity. The primary reflector panels are highly specular to achieve precise lamp arc reflections toward the proper areas on the ground. Excessive straight-down illumination is avoided by the elimination of downward reflecting surfaces.

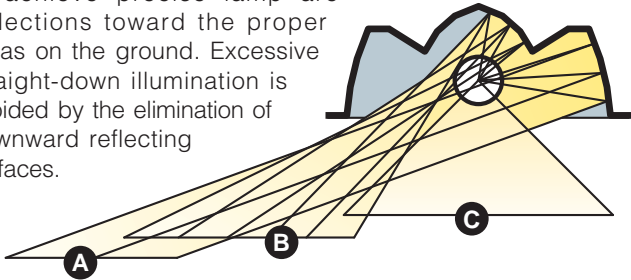

- A.** High-angle maximum candlepower and full cutoff are produced by the smooth specular side panels.
- B.** A specular peened upper reflector spreads light into the mid-range, gradually increasing the intensity toward higher angles while avoiding any low-angle reflections.
- C.** At low angles, bare lamp illumination is more than adequate. The elimination of downward reflecting surfaces greatly increases uniformity.

Structural is StarView™ Compliant.

Kim Lighting's StarView products are designated for luminaires that meet IES full cutoff requirements for use where light pollution or light trespass may be a concern and to promote the enjoyment of celestial visibility at night.

StarView™
compliant

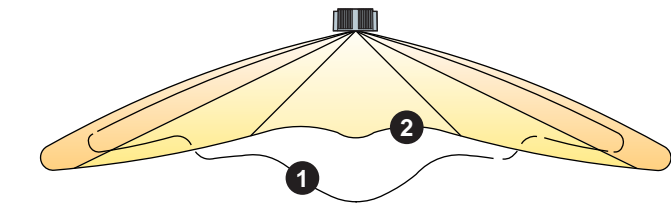

1. Typical horizontal lamp luminaires produce excessive straight-down illumination in relation to the side throw. This causes poor uniformity.
2. Kim Lighting's Structural reflectors have reduced straight-down illumination with increased side throw. This produces excellent pole spacing and uniformity.



StarView™
compliant



Optical System Features

Rotatable Optics

Structural™ reflectors are die-cast and field rotatable in 90° increments. This allows design flexibility in producing very high illumination levels for special applications or for maintaining a consistent fixture orientation throughout the site. Each reflector is labeled to show the orientation of the light pattern, and can be field adjusted.

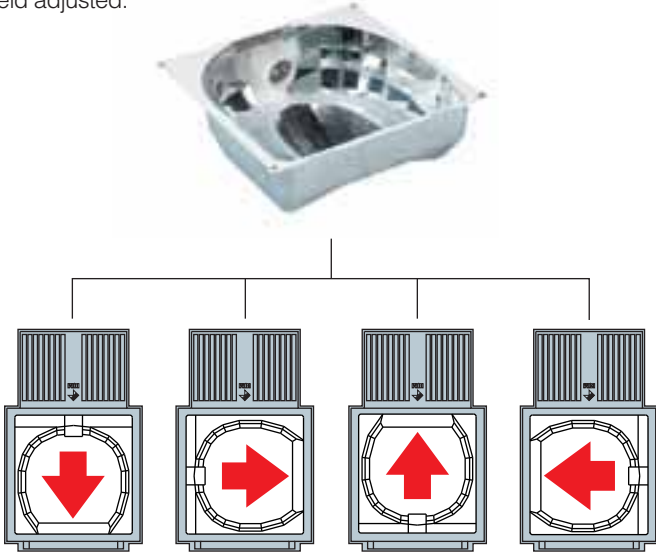

Rotatable reflectors offer refinement of fixture orientation to suit unique site requirements.

When twin-mounted luminaires are used for site lighting using Types II, III or IV distributions, the combined effect from the twin mount is a rectangular light pattern.

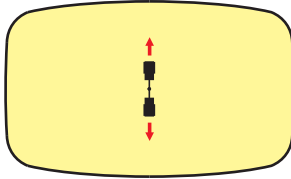

An identical light pattern can be achieved, with the luminaires rotated 90°, by rotating the reflectors as shown.

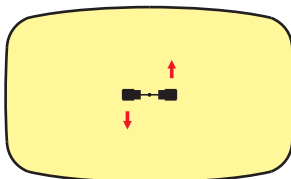

For applications requiring high light levels, such as tennis courts and automobile dealerships, reflectors can be aimed in parallel to double illumination levels.

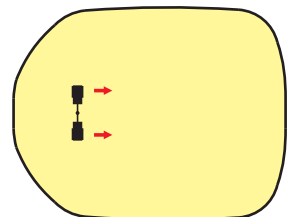

Totally Sealed Optics

Kim Lighting's optical systems stay clean for two reasons. First, only one-piece silicone gaskets are used, which have high memory retentive qualities and very low outgassing. Second, the optical chamber is completely sealed from all moisture, air, and insect entry both externally and internally. The optical chamber has an IP66 rating.

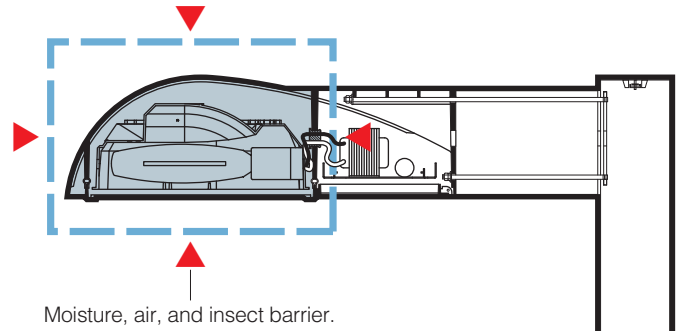

Four Light Distributions

Site geometry determines the specific light distribution or combination of light distributions that will efficiently light the areas. Twenty-five years of cutoff lighting experience has shown us that four light distributions will satisfy any site requirement, from parking lots and roadways to pathways and courtyards.

Structural is available in four highly efficient light patterns as shown at right. Combine these with seven mounting arrangements and rotatable optics and you have an incredibly versatile lighting system that will efficiently light any site. In addition, houseside shields are available for locations where spill light must be restricted from adjacent property.

Seven Mounting Arrangements

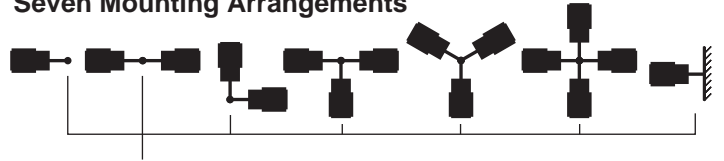

Seven mounting configurations are available using one to four fixtures per pole, plus single wall mounting.

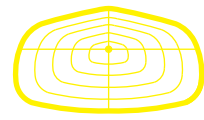

Type II

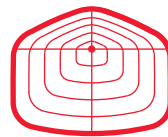

Type III

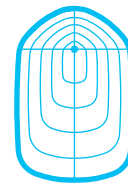

Type IV
Forward Throw



Type V
Square

Houseside shields available on Types II, III, and IV distributions only.



Mechanical Design Features

Structural Options

Four Structural™ elements are available to complement similar architectural features. All Structural options are constructed of aluminum, attached to fixture and pole with cast fittings and stainless steel fasteners. While these options do add strength, the primary mounting arm is engineered to handle all static and wind load stresses.



Single or Double Tension Rods



Truss



Arm Gusset



Die-Cast Housing and Lens Frame

Precision, strength, and clean detailing are achieved by die-casting these primary components. Integral cooling fins substantially reduce operating temperatures on heat-sensitive electrical components, promoting extended life.



Standard Support Arm

The extruded mounting support arm is an extension of the housing, with internal bolt tracks to align and conceal the fixture-to-pole mounting hardware.

Optional Support Arms

See photos on page 21 and refer to Kim Lighting's **Architectural Arms** Catalog for complete selection and details.

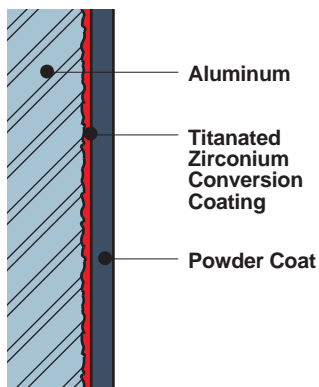

Durable Powder Coat Finish

Kim Lighting's state-of-the-art powder coat paint system is engineered to provide the highest quality finish with absolute paint adhesion under weather extremes. The Super TGIC thermoset polyester powder coat finish is applied over a titanated zirconium conversion coating. This finish system has exceeded the A.S.T.M. 2500 hour salt spray test.

Eight Stage Finish

1. Power wash and degrease.
2. Detergent tank bath.
3. Clear water rinse bath.
4. Premium titanated zirconium conversion coating as used in the automobile industry.
5. Clear water rinse bath.
6. Dry off oven.
7. Powder coating, 2.5 mil nominal thickness.
8. Bake for 20 minutes at 410°F.

Standard Arm Mount Installation

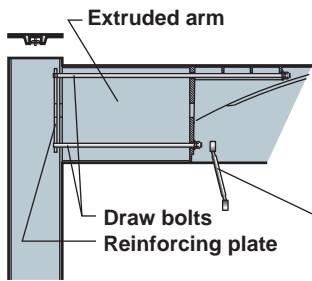

Arm Mount installations utilize a draw-bolt system concealed within the arm's internal centering guides.

Easy socket wrench access through housing

Optional Vertical Slipfitter Installation

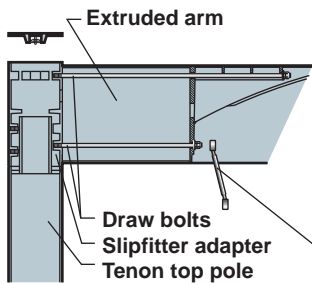

Vertical Slipfitter installations utilize a slipfitter adapter to which the fixture arm is bolted. Adapter slipfits tenon and is held in place by four set screws. One set screw is drilled into the tenon to eliminate rotation.

Easy socket wrench access through housing

Optional Horizontal Slipfitter Installation

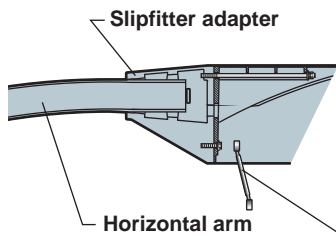

Horizontal Slipfitter installations utilize a slipfitter adapter to which the fixture housing is bolted. Adapter slipfits to horizontal arm. Six stainless steel set screws secure adapter to arm, one set screw is drilled into the arm to prevent fixture rotation.

Easy socket wrench access through housing

Optional Wall Mount Installation - see page 18 for details.



Easy Installation

The Structural™ arm connection is both clean and strong, utilizing an internal draw-bolt system.

Inside the pole top, a reinforcing plate receives the draw-bolts. A strain relief is provided for securing the field wires. The one-piece arm extrusion has internal bolt guides which position the arm during mounting. Final securing is accomplished inside the fixture using a socket wrench. Ample access is provided because the ballast module and lens frame snap out.

Ballast components are tray mounted to provide a removable electrical module. Electrical modules can be easily removed and replaced without tools, with quick-disconnect plugs for ease of maintenance.



Lens Frame

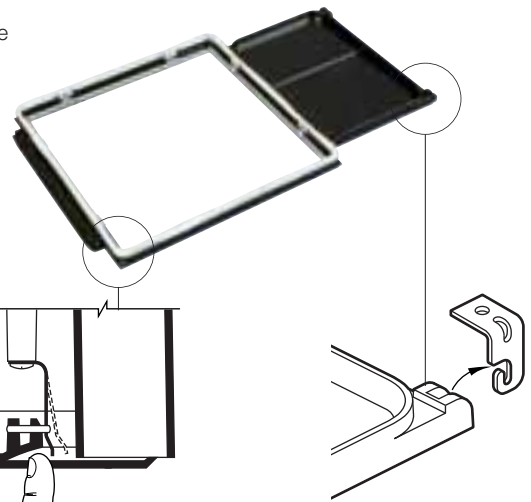

Thumb-latch Detail

Hanger Hook Hinge Detail

No-Tool Maintenance

To reduce expensive lift-truck rental time, relamping is quickly accomplished without tools. The lens frame is opened by two thumb latches located at the front corners of the lens frame. The entire electrical module snaps out without tools and includes quick-disconnect plugs on all wiring. A spare module can be quickly inserted to eliminate downtime, while the old module is repaired and stored for future use.

The lens frame is also removable without tools, providing easy lens replacement in the unusual event that breakage occurs. For additional safety during relamping, the door frame is prevented from lifting out of its hinges when hanging in the normal down position.





Ordering Information

1000W Structural

STX
Mogul Base
600 to 1000 Watt

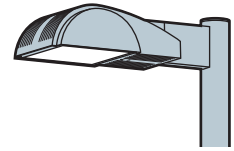

Ordering Example:

For Fixture,
Structural Option and Pole

Mounting	Fixture	Electrical Module	Finish	Options	Structural Option ¹	Pole
2B	/STX3/	1000MH277/	PS	/AA09/	TSN /	LTRA30-8156-TS / PS
1	2	3	4	5-11	12	13

¹See notes on page 13 for option #12.

See separate Kim Pole Catalog. Omit for 1W Wall Mount.

1 Mounting:

3Y configuration is available for round poles only.

Plan View:



EPA:	3.5	7.0	4.5	8.0	8.0	8.5	—
Cat. No.:	1A	2B	2L	3T	3Y	4C	1W

2 Fixture:

Cat. No. designates **STX** fixture and light distribution.

See the Kim Site/Roadway Optical Systems Catalog for detailed information on reflector design and application.

Horizontal Lamp Flat Lens



Light Distribution:



Type II
Full Cutoff



Type III
Full Cutoff



Type IV
Forward Throw
Full Cutoff
STX4



Type V
Square
Full Cutoff
STX5

Cat. No.:

STX2

STX3

STX4

STX5

3 Electrical Module:

PMH = Pulse Start
Metal Halide

MH = Metal Halide

HPS = High Pressure Sodium

See lamp and electrical data on pages 28 - 29 for ballast types and characteristics.

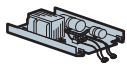

Lamp Watts	Lamp Type	Line Volts
1000	MH	277

Pulse Start
Metal Halide

750PMH120
750PMH208
750PMH240
750PMH277
750PMH347
750PMH480
1000PMH120
1000PMH208
1000PMH240
1000PMH277
1000PMH347
1000PMH480

Metal Halide

1000MH120
1000MH208
1000MH240
1000MH277
1000MH347
1000MH480

High Pressure Sodium

600HPS120 **1000HPS120**
600HPS208 **1000HPS208**
600HPS240 **1000HPS240**
600HPS277 **1000HPS277**
600HPS347 **1000HPS347**
600HPS480 **1000HPS480**
750HPS120
750HPS208
750HPS240
750HPS277
750HPS347
750HPS480

4 Finish:

Super TGIC powder coat paint over titanated zirconium conversion coating.

Color:	Black	Dark Bronze	Light Gray	Platinum Silver	White	Custom Colors
Cat. No.:	BL	DB	LG	PS	WH	CC

Consult representative for custom colors.

5 Optional Photocell Receptacle:

Receptacle provided for NEMA base photocells (by others).

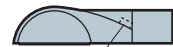

Receptacle

Cat. No.: **A-25**

For multiple mounting configurations, each fixture is supplied with an individual Photocell Receptacle.

6 Optional Convex Glass Lens:



Convex Lens

Cat. No.: **CGL**

Tempered convex glass lens replaces standard flat lens.

NOTE: Brightness control goes from Full Cutoff to Cutoff.

7 Optional Houseside Shield:

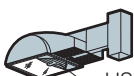

HS for flat lens only

Cat. No.: **HS**

Not recommended for use with HPS lamps due to arc tube length. Recommended for use with clear lamps only. Effectiveness is reduced with coated lamps. Not for use with Type V light distribution.



HSC for convex lens

Cat. No.: **HSC**

For fixtures with optional convex glass lens. Not recommended for HPS lamps due to arc tube length. Recommended for use with clear lamps only. Effectiveness is reduced with coated lamps. Not for use with Type V light distribution.

8 Optional Vertical Slipfitter Mounts:

Mounting Configuration
 1XA - Single arm mount
 2XB - 2 at 180°
 2XL - 2 at 90°
 3XT - 3 at 90°
 3XY - 3 at 120°
 4XC - 4 at 90°

For existing pole installation or for use with poles provided by others.

For Standard Fixtures

Cat. No.:
VSF-1XA
VSF-2XB
VSF-2XL
VSF-3XT
VSF-3XY
VSF-4XC 4" Round



Cat. No.:
SVSF-1XA
SVSF-2XB
SVSF-2XL
SVSF-3XT
SVSF-4XC 4" Square



NOTE: For Fixtures with Structural Options Only

Cat. No.:
STRF-1XA
STRF-2XB
STRF-2XL
STRF-3XT
STRF-3XY
STRF-4XC 4" Round



Cat. No.:
STSF-1XA
STSF-2XB
STSF-2XL
STSF-3XT
STSF-4XC 4" Square

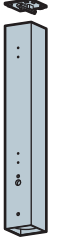

Allows fixture, arm, and Structural Option (when applicable) to be mounted to steel poles having a steel 2" pipe-size tenon (2 3/8" O.D. x 4 1/2" min. length). Not available for **GS** Gusset.

9 Optional Support Arm:

NOTE: Refer to Kim Lighting's Architectural Arms Catalog for complete details.

Optional Support Arm **cannot be used with #12** Pole Mounted Structural Option.

Refer to Architectural Arms Catalog for wall mounting feature.

Arm Cat. No.:

AA01

AA03

AA05

AA07

AA09

AA11

Mounting:

Optional Support Arm:
 Swept Solid Arm

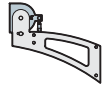
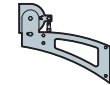

Mounting:	Optional Support Arm:	AA01	AA03	AA05	AA07	AA09	AA11
1A	EPA for fixture and arm:	3.1	2.7	3.3	2.8	3.5	3.5
2B		6.2	5.4	6.6	5.6	7.0	7.0
2L		4.1	3.7	4.3	3.8	4.5	4.5
3T		7.2	6.4	7.6	6.6	8.0	8.0
3Y		7.2	6.4	7.6	6.6	8.0	8.0
4C		7.7	6.9	7.9	6.9	8.5	8.5

10 Optional Horizontal Slipfitter Mount:

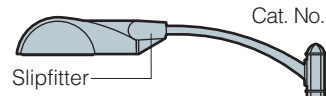

Cat. No.: **HSF**

Replaces standard mounting arm with a slipfitter for mounting to a horizontal pole davit-arm with 2" pipe-size mounting end (2 3/8" O.D.). Provides ±5° vertical fixture adjustment.

11 Special Options for Street Lighting:

Cat. No.: **TB**

Terminal Block located inside the fixture electrical compartment.

Cat. No.: **AF**

Air Filter to allow ventilation through the optical chamber.

12 Structural Option:

NOTE: For use with Standard Straight Arm Only.

Pole Mounted Structural Option **cannot be used with #9** Optional Support Arm.

Pole Mounted Structural Options

Single Tension

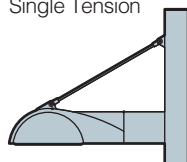

Cat. No.:
TSP - Rod and clevis painted to match fixture.
TSN - Stainless steel rod with nickel plated clevis.

Double Tension

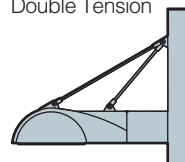

Cat. No.:
TDP - Rod and clevis painted to match fixture.
TDN - Stainless steel rod with nickel plated clevis.

Truss

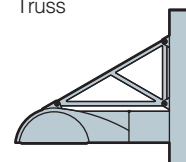

Cat. No.:
TR

Gusset

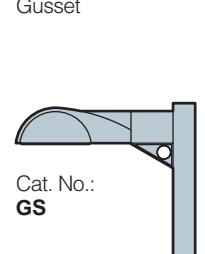

Cat. No.:
GS

Wall Mounted Structural Options

Single Tension

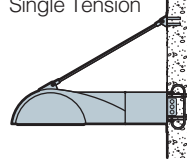

Cat. No.:
TSP-W - Rod and clevis painted to match fixture.
TSN-W - Stainless steel rod with nickel plated clevis.

Double Tension

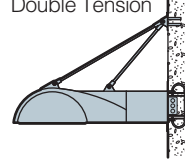

Cat. No.:
TDP-W - Rod and clevis painted to match fixture.
TDN-W - Stainless steel rod with nickel plated clevis.

Truss

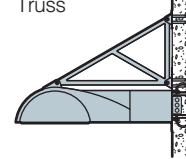

Cat. No.:
TR-W

Gusset

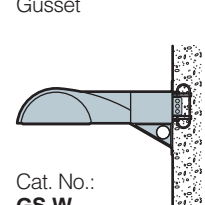

Cat. No.:
GS-W

13 Poles:

See Kim Pole Catalog for a complete selection of round and square poles in aluminum or steel.

9 Optional Vertical Slipfitter Mounts:

Mounting Configuration
 1A - Single arm mount
 2B - 2 at 180°
 2L - 2 at 90°
 3T - 3 at 90°
 3Y - 3 at 120°
 4C - 4 at 90°

For existing pole installation or for use with poles provided by others.

For Standard Fixtures

Cat. No.:
VSF-1A
VSF-2B
VSF-2L
VSF-3T
VSF-3Y
VSF-4C



4" Round

Cat. No.:
SVSF-1A
SVSF-2B
SVSF-2L
SVSF-3T
SVSF-4C



4" Square

NOTE: For Fixtures with Structural Options Only

Cat. No.:
STRF-1A
STRF-2B
STRF-2L
STRF-3T
STRF-3Y
STRF-4C



4" Round

Cat. No.:
STSF-1A
STSF-2B
STSF-2L
STSF-3T
STSF-4C

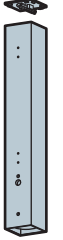

4" Square

Allows fixture, arm, and Structural Option (when applicable) to be mounted to steel poles having a steel 2" pipe-size tenon (2 $\frac{3}{8}$ " O.D. x 4 $\frac{1}{2}$ " min. length). Not available for **GS** Gusset.

10 Optional Support Arm:

NOTE: Refer to Kim Lighting's Architectural Arms Catalog for complete details.

Optional Support Arm **cannot be used with #13 Pole Mounted Structural Option.**

Refer to Architectural Arms Catalog for wall mounting feature.

Arm Cat. No.:

AA01

AA03

AA05

AA07

AA09

AA11

Mounting:

Optional Support Arm:



Swept Solid Arm



Swept Hollow Arm



Upsweep Solid Arm



Upsweep Hollow Arm

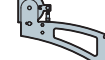

Uplift Adjustable Aluminum Arm



Uplift Adjustable Stainless Steel Arm

1A

EPA for fixture

2.2

1.8

2.4

1.9

2.6

2.6

2B

and arm:

4.4

3.6

4.8

3.8

5.2

5.2

2L

2.8

2.4

3.0

2.5

3.2

3.2

3T

5.0

4.2

5.4

4.4

5.8

5.8

3Y

5.0

4.2

5.4

4.4

5.8

5.8

4C

5.3

4.5

5.7

4.7

6.1

6.1

11 Optional Horizontal Slipfitter Mount:

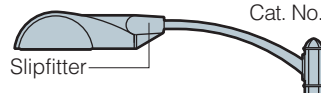

Cat. No.: **HSF**

Replaces standard mounting arm with a slipfitter for mounting to a horizontal pole davit-arm with 2" pipe-size mounting end (2 $\frac{3}{8}$ " O.D.). Provides $\pm 5^\circ$ vertical fixture adjustment.

12 Special Options for Street Lighting:

Cat. No.: **TB**

Terminal Block located inside the fixture electrical compartment.

Cat. No.: **AF**

Air Filter to allow ventilation through the optical chamber.

13 Structural Option:

NOTE: For use with Standard Straight Arm Only.

Pole Mounted Structural Option **cannot be used with #10 Optional Support Arm.**

Pole Mounted Structural Options

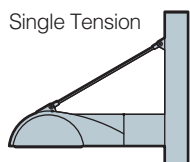

Cat. No.:
TSP - Rod and clevis painted to match fixture.
TSN - Stainless steel rod with nickel plated clevis.

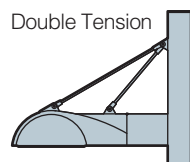

Cat. No.:
TDP - Rod and clevis painted to match fixture.
TDN - Stainless steel rod with nickel plated clevis.

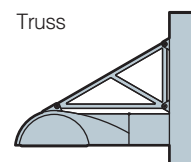

Cat. No.:
TR

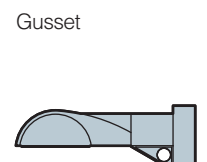

Cat. No.:
GS

Wall Mounted Structural Options

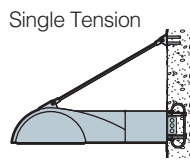

Cat. No.:
TSP-W - Rod and clevis painted to match fixture.
TSN-W - Stainless steel rod with nickel plated clevis.

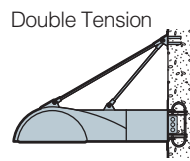

Cat. No.:
TDP-W - Rod and clevis painted to match fixture.
TDN-W - Stainless steel rod with nickel plated clevis.

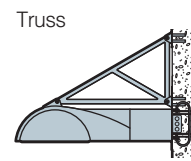

Cat. No.:
TR-W

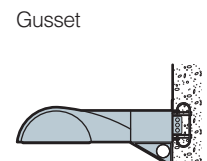

Cat. No.:
GS-W

14 Poles:

See Kim Pole Catalog for a complete selection of round and square poles in aluminum or steel.

Ordering Information

175W Small Structural

STS
Medium Base
70 to 175 Watt

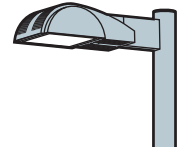

	Mounting	Fixture	Electrical Module	Finish	Options	Structural Option ¹	Pole	
Ordering Example: For Fixture, Structural Option and Pole	1SA/STS3/175MH277/		WH	/AA10/	TSN /	PRA12-34188-TS/WH		
	1	2	3	4	5-13	14	15	
						¹ See notes on page 17 for option #14.	See separate Kim Pole Catalog. Omit for 1W Wall Mount.	
1 Mounting: 3SY configuration is available for round poles only.	Plan View:							
	EPA:	1.1	2.2	1.5	2.6	2.6	2.7	—
	Cat. No.:	1SA	2SB	2SL	3ST	3SY	4SC	1SW
2 Fixture: Cat. No. designates STS fixture and light distribution. See the Kim Site/Roadway Optical Systems Catalog for detailed information on reflector design and application.	Horizontal Lamp Flat Lens							
	Light Distribution:		Type II Full Cutoff	Type III Full Cutoff	Type IV Forward Throw Full Cutoff	Type V Square Full Cutoff		
	Cat. No.:		STS2	STS3	STS4	STS5		
3 Electrical Module: PMH = Pulse Start Metal Halide MH = Metal Halide HPS = High Pressure Sodium PL = Compact Fluorescent Triple Tube IF = Induction Fluorescent See lamp and electrical data on pages 28 - 29 for ballast types and characteristics.	Pulse Start Metal Halide		Metal Halide	High Pressure Sodium		Compact Fluorescent	Induction Fluorescent	
	50PMH120	100PMH120	175MH120	70HPS120	150HPS120	42PL120	55IF120	
	50PMH208	100PMH208	175MH208	70HPS208	150HPS208	42PL208	55IF208	
	50PMH240	100PMH240	175MH240	70HPS240	150HPS240	42PL240	55IF240	
	50PMH277	100PMH277	175MH277	70HPS277	150HPS277	42PL277	55IF277	
	50PMH347	100PMH347	175MH347	70HPS347	150HPS347	57PL120		
	70PMH120	100PMH480	175MH480	70HPS480	150HPS480	57PL208		
	70PMH208	150PMH120		100HPS120		57PL240		
	70PMH240	150PMH208		100HPS208		57PL277		
	70PMH277	150PMH240		100HPS240		60PL120		
	70PMH347	150PMH277		100HPS277		60PL208		
	70PMH480	150PMH347		100HPS347		60PL240		
		150PMH480		100HPS480		60PL277		
	Lamp Watts	Lamp Type	Line Volts					
	175	MH	277					
4 Finish: Super TGIC powder coat paint over titanated zirconium conversion coating.	Color:	Black	Dark Bronze	Light Gray	Platinum Silver	White	Custom Colors	
	Cat. No.:	BL	DB	LG	PS	WH	CC	
							Consult representative for custom colors.	
5 Optional Base Socket:			Cat. No.:	G12	Optional G12 base socket available for 70W and 150W Pulse Start Metal Halide lamps only.			
6 Optional Photocell Control:		Cat. No. and Line Volts:	A-30 120V A-31 208V A-32 240V A-33 277V A-35 347V	Mounting Configuration	* – Fixture with Photocell Sensor s – slave unit(s) No fixture wattage limit.			
					1SA or 1SW 2SB 3ST, 3SY 4SC			
7 Optional Convex Glass Lens:		Cat. No.:	CGL	Tempered convex glass lens replaces standard flat lens. NOTE: Brightness control goes from Full Cutoff to Cutoff.				
8 Optional Polycarbonate Lens:		Cat. No.:	LS	Polycarbonate Lens replaces standard tempered glass lens. 250 Watt Maximum. May be used with 400HPS in outdoor locations where ambient air temperature during fixture operation will not exceed 85°F. Changes light distribution from Full Cutoff to Cutoff. See "CAUTION" on page 19.				
9 Optional Houseside Shield:		Cat. No.:	HS	Recommended for use with clear lamps only. Effectiveness is reduced with coated lamps. Not for use with Type V light distribution.				
		Cat. No.:	HSC	For fixtures with optional convex glass lens. Recommended for use with clear lamps only. Effectiveness is reduced with coated lamps. Not for use with Type V light distribution.				

10 Optional Vertical Slipfitter Mounts:

Mounting Configuration
 1SA - Single arm mount
 2SB - 2 at 180°
 2SL - 2 at 90°
 3ST - 3 at 90°
 3SY - 3 at 120°
 4SC - 4 at 90°

For existing pole installation or for use with poles provided by others.

For Standard Fixtures

Cat. No.
VSF-1SA
VSF-2SB
VSF-2SL
VSF-3ST
VSF-3SY
VSF-4SC



4" Round

Cat. No.
SVSF-1SA
SVSF-2SB
SVSF-2SL
SVSF-3ST
SVSF-4SC



4" Square

NOTE: For Fixtures with Structural Options Only

Cat. No.
STRF-1SA
STRF-2SB
STRF-2SL
STRF-3ST
STRF-3SY
STRF-4SC



4" Round

Cat. No.
STSF-1SA
STSF-2SB
STSF-2SL
STSF-3ST
STSF-4SC

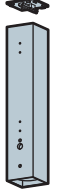

4" Square

Allows fixture, arm, and Structural Option (when applicable) to be mounted to steel poles having a steel 2" pipe-size tenon (2 $\frac{3}{8}$ " O.D. x 4 $\frac{1}{2}$ " min. length). Not available for **GS** Gusset.

11 Optional Support Arm:

NOTE: Refer to Kim Lighting's Architectural Arms Catalog for complete details.

Optional Support Arm **cannot be used with #14 Pole Mounted Structural Option.**

Refer to Architectural Arms Catalog for wall mounting feature.

Arm Cat. No.:

AA02

AA04

AA06

AA08

AA10

AA12

Mounting:

Optional Support Arm:



Swept Solid Arm



Swept Hollow Arm



Upsweep Solid Arm



Upsweep Hollow Arm



Uplift Adjustable Aluminum Arm



Uplift Adjustable Stainless Steel Arm

1SA

2SB

2SL

3ST

3SY

4SC

EPA for fixture and arm:

1.0

2.0

1.4

2.4

2.4

2.5

0.9

1.8

1.3

2.2

2.2

2.3

1.1

2.2

1.5

2.6

2.6

2.7

1.0

2.0

1.4

2.4

2.4

2.5

1.3

2.6

1.8

3.1

3.1

3.5

1.3

2.6

1.8

3.1

3.1

3.5

12 Optional Horizontal Slipfitter Mount:

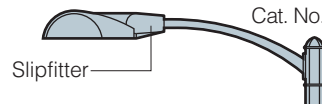

Cat. No.: **HSF**

Slipfitter

Replaces standard mounting arm with a slipfitter for mounting to a horizontal pole davit-arm with 2" pipe-size mounting end (2 $\frac{3}{8}$ " O.D.). Provides $\pm 5^\circ$ vertical fixture adjustment.

13 Special Options for Street Lighting:

Cat. No.: **AF**

Air Filter to allow ventilation through the optical chamber.

14 Structural Option:

NOTE: For use with Standard Straight Arm Only.

Pole Mounted Structural Option **cannot be used with #11 Optional Support Arm.**

Pole Mounted Structural Options

Single Tension

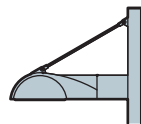

Cat. No.:

TSP - Rod and clevis painted to match fixture.

TSN - Stainless steel rod with nickel plated clevis.

Double Tension

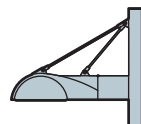

Cat. No.:

TDP - Rod and clevis painted to match fixture.

TDN - Stainless steel rod with nickel plated clevis.

Truss

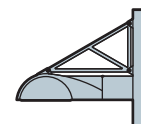

Cat. No.:

TR

Gusset

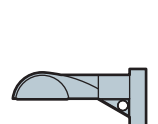

Cat. No.:

GS

Wall Mounted Structural Options

Single Tension

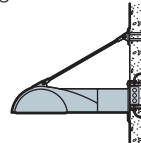

Cat. No.:

TSP-W - Rod and clevis painted to match fixture.

TSN-W - Stainless steel rod with nickel plated clevis.

Double Tension

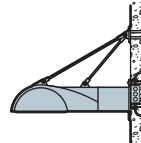

Cat. No.:

TDP-W - Rod and clevis painted to match fixture.

TDN-W - Stainless steel rod with nickel plated clevis.

Truss

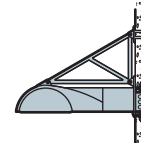

Cat. No.:

TR-W

Gusset

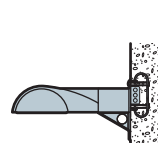

Cat. No.:

GS-W

15 Poles:

See Kim Pole Catalog for a complete selection of round and square poles in aluminum or steel.

Luminaire Specifications

Structural™ Models

Dimensions

STX Model

600 to 1000 watt
Mogul Base Lamps

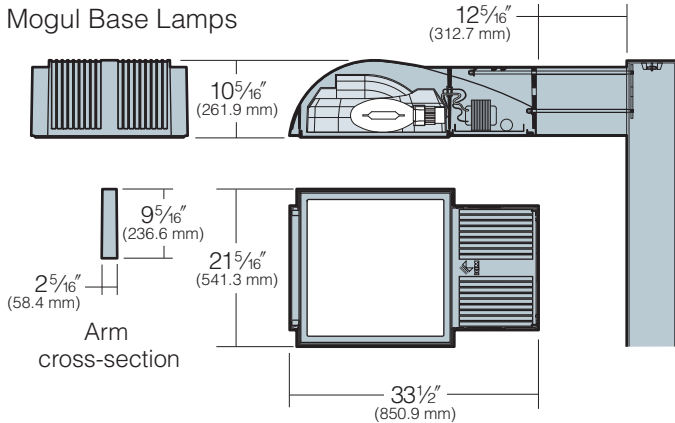

STL Model

150 to 400 watt
Mogul Base Lamps

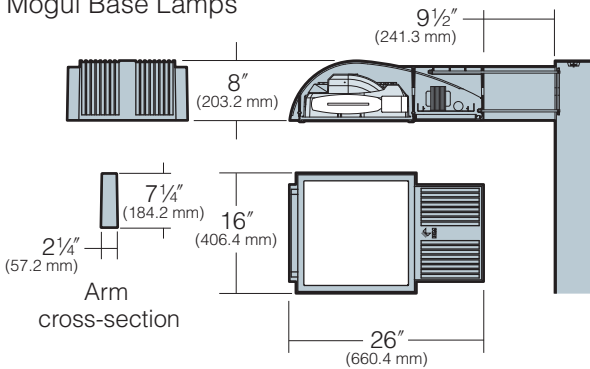

STS Model

70 to 175 watt
Medium Base Lamps

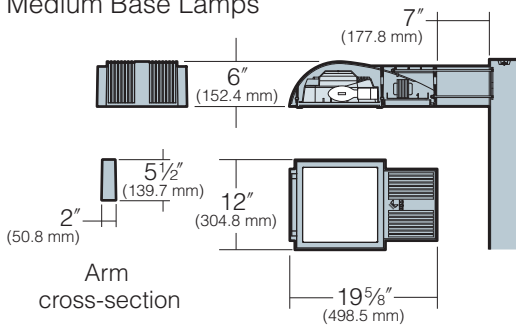

Housing: One-piece die-cast, low copper alloy (<0.6% Cu) aluminum with integral cooling fins on top surfaces above the optical chamber and electrical compartment. A solid barrier wall separates the optical and electrical compartments with gasketed wire penetrations. A double-thick wall with gussets is provided on the support arm mounting end. All hardware is stainless steel.

Lens Frame: One-piece die-cast, low copper alloy (<0.6% Cu) aluminum with a 1" minimum thickness around the gasket flange for rigidity. Integral hinges with stainless steel pins provide no-tool mounting and removal from the housing. Two stainless steel thumb-latches are recessed into the front corners, concealed from normal view. Lens frame seals against the housing by a one-piece extruded silicone gasket with vulcanized end closure. Clear 3/16" thick tempered flat glass is retained in the frame by eight clips with full silicone gasketing around the perimeter.

Reflector Module: Specular Alzak® optical segments are rigidly mounted in a die-cast, low copper alloy (<0.6% Cu) aluminum frame which attaches to the housing as a one-piece module with captive stainless steel screws. Reflector module is field-rotatable in 90° increments. For the 1000W STX model, all HPS and MH lamps are braced with a lamp vibration clamp and use 5KV mogul base sockets. For the Large STL model, all HPS and pulse start lamps use 4KV mogul base sockets, while HOR-MH lamps use pin-oriented mogul base sockets with a molded silicone lamp stabilizer. For all Small STS models, sockets are 4KV medium base. All sockets are factory prewired with a quick-disconnect plug for the ballast module, with wires passing through a silicone gasket in the housing barrier wall. Four light distributions are available and interchangeable within the same housing size.

Electrical Module: All electrical components are UL and CSA recognized, mounted on a single plate and factory prewired with quick-disconnect plugs. Electrical module attaches to the housing with no-tool hinges and latches, accessible by opening the lens frame. All ballasts are high power factor with starting temperatures of -40°F for HPS and -20°F for MH lamp modes. See lamp and electrical data on pages 28 - 29 for ballast types and characteristics.

Support Arm: One-piece extruded aluminum with internal bolt guides. Luminaire-to-pole attachment is by internal draw bolts, and includes a pole reinforcing plate with wire strain relief. For mounting to round poles, arm is circular cut for precise mating to the pole diameter.

Finish/Color: Finish is Super TGIC thermoset polyester powder coat paint, 2.5 mil nominal thickness, applied over a titanated zirconium conversion coating; A.S.T.M. 2500 hour salt spray test endurance rating. Standard colors are Black, Dark Bronze, Light Gray, Platinum Silver, or White. Custom colors are available.

CAUTION: Fixtures must be grounded in accordance with national, state and/or local electrical codes. Failure to do so may result in serious personal injury.

Listings and Ratings

UL cUL 1598 ¹	—	25C Ambient
IP66 Rated	CE	
Full-Cutoff ² with flat glass lens Cutoff with convex glass lens		

¹Suitable for wet locations

²Dark Sky Legislation Compliant

Optional Wall Mounts

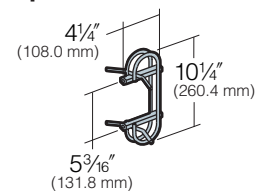

The wall embedment bracket (included with all wall mounted luminaires) provides 3/8"-16 bolt receptacles welded in a galvanized re-bar cage for casting into poured-in-place concrete walls. Bolt receptacles receive fixture attachment bolts.

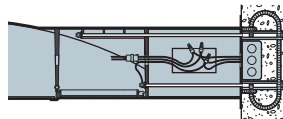

STX / STL Large Structural model is mounted to wall using 3/8"-16 arm draw bolts threaded into the wall embedment bracket. Aluminum bearing plate provided, finished to match fixture.

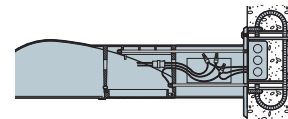

STS Small Structural model is mounted to wall using 3/8"-16 arm draw bolts threaded into the wall embedment bracket. Aluminum bearing plate provided, finished to match fixture.

NOTE: Optional Support Arms - See photos on page 21 and refer to Kim Lighting's "Architectural Arms" Catalog for complete selection and details.

Option Specifications

See pages 12-17 for complete ordering information

Photocell Control: 1000W STX and Large STL models supplied with a fully gasketed receptacle above the electrical compartment for NEMA base photocell (by others). **STX:** Every fixture has a photocell receptacle. **STL:** For multiple-fixture pole mountings with two or three fixtures, one fixture has a receptacle to operate the others. Four fixtures (250 watt or less) require one fixture with a receptacle. Four fixtures (400 watt) require two fixtures with receptacles. **STS:** Small STS models supplied with an internal photocell with the sensor on the housing side wall. For multiple-fixture pole mountings, one fixture has a photocell to operate the others.

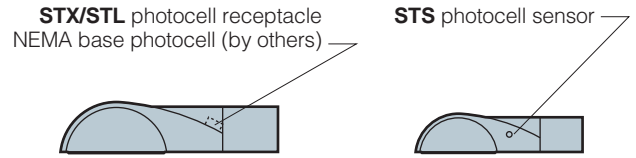

Convex Glass Lens (CGL): The 3/16" thick clear convex tempered glass lens replaces the standard flat glass lens. Gives increased lens presence and provides a subtle improvement in uniformity where pole spacing is extreme. Increases effectiveness of houseside shielding.

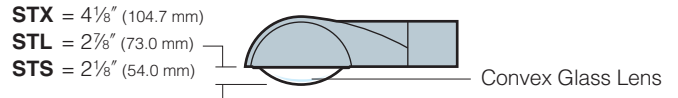

Polycarbonate Lens (LS): STL/STS only. One-piece vacuum formed, clear, UV stabilized convex polycarbonate, fully gasketed, replacing the standard tempered glass lens. 250 watt maximum in STL models, 400 watt HPS may be used in outdoor locations where ambient air temperature during fixture operation will not exceed 85°F.

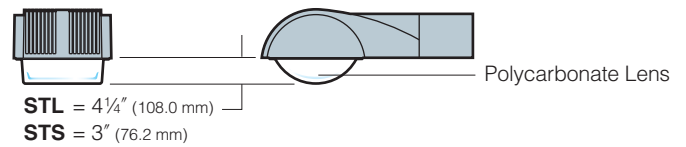

CAUTION: Use only when vandalism is anticipated to be high. Useful life is limited by UV discoloration from sunlight and metal halide lamps.

Houseside Shield (HS/HSC): Types II, III, and IV only. Fixtures with the standard flat glass lens are available with stamped aluminum louvers that pass streetside light and block houseside light, also a black panel is added to the reflector to reduce houseside reflections. Fixtures with the optional convex glass lens are available with a formed aluminum shield that passes streetside light and blocks houseside light, also with a black panel added to the reflector to reduce houseside reflections. Use with clear lamps only, as coated lamps reduce effectiveness.

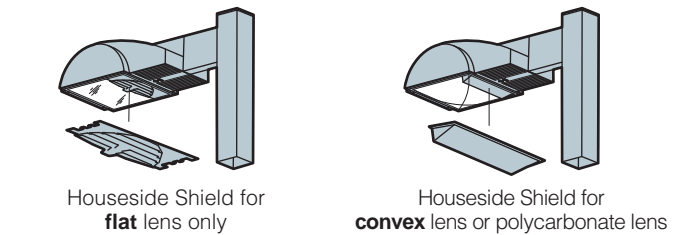

Horizontal Slipfitter Mount (HSF): Replaces standard mounting arm with a slipfitter which allows STX, STL, or STS models to be mounted to a horizontal pole davit-arm with 2" pipe-size mounting end (2 3/8" O.D.). Cast aluminum slipfitter with set screws providing ±5° vertical fixture adjustment. Bolts to housing from inside the electrical compartment using mounting holes for the standard support arm. Davit-arm must be field drilled at a set screw location to insure against fixture rotation. Finished to match fixture.

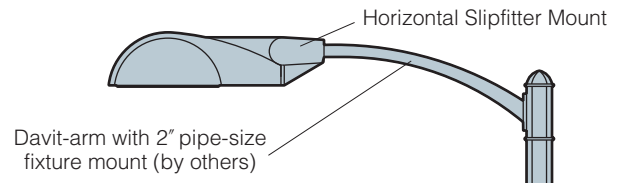

Special Options for Street Lighting

Air Filter (AF): Allows for ventilation through the optical chamber, filtering all air particles above 500 microns. Multi-layer disc assembly mounted on solid wall between optical and front compartments.

Terminal Block (TB): For field wire connections in STX/STL models only. 85AMP, 600V box clamp terminal block mounted to the housing inside the electrical compartment. Each port accepts wire sizes #14AWG through #4AWG. Factory prewired to electrical module quick-disconnect plug.

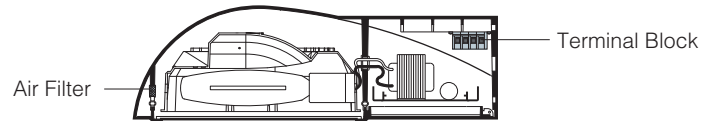

Vertical Slipfitter Mounts

For standard fixtures (VSF): Allows STX, STL, or STS models with standard support arm to be mounted to steel poles having a steel 2" pipe-size tenon (2 3/8" O.D. x 4 1/2" min. length). 4" round or square cast aluminum with flush cap, secured to pole tenon by four 3/8" stainless steel set point allen screws. Finished to match fixture and arm.

For fixtures with Structural Options (STRF/STSF): Allows STX, STL, or STS models with structural options to be mounted to steel poles having a steel 2" pipe-size tenon (2 3/8" O.D. x 4 1/2" min. length). 4" round or square extruded aluminum with internal cast aluminum reinforcement, flush cap, secured to pole tenon by four 3/8" stainless steel set point allen screws. Finished to match fixture and arm.

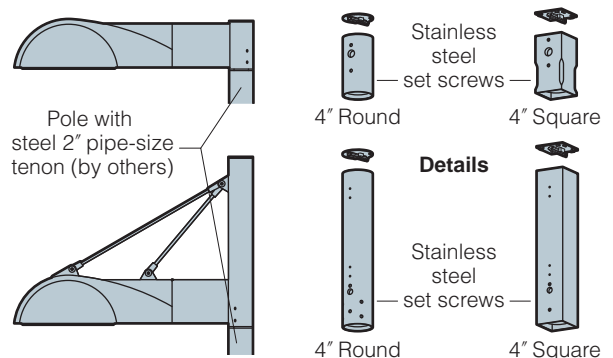

Pole Mounted Structural Options

See pages 12-17 for complete ordering information.

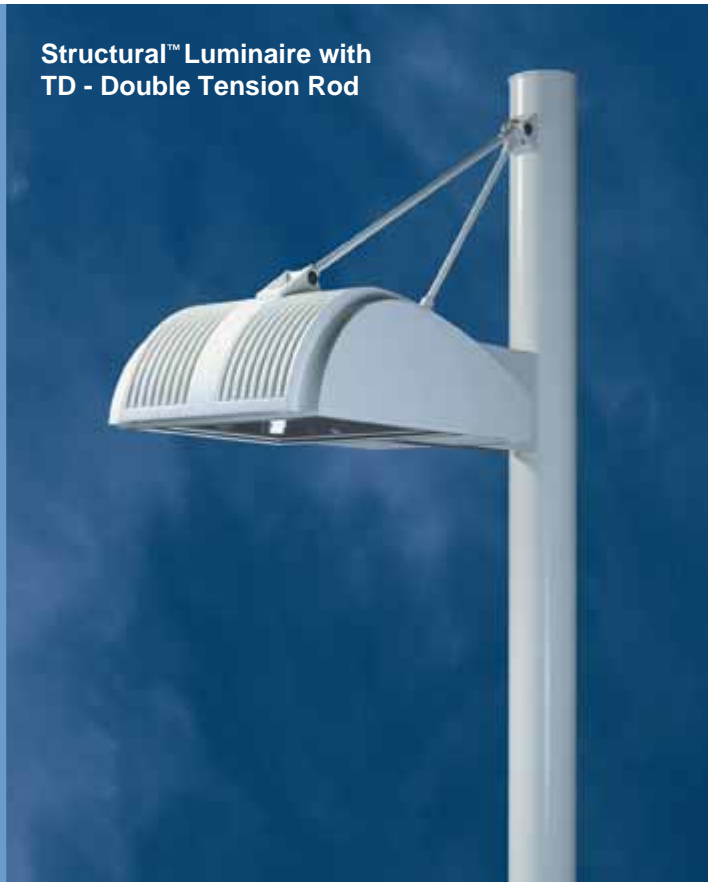
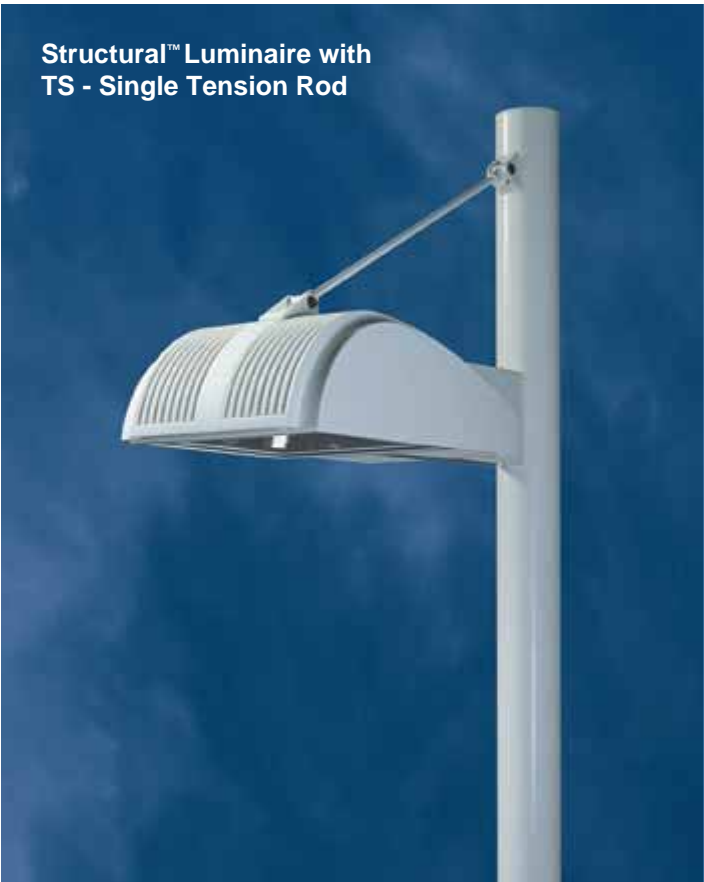

Optional Support Arms

Refer to Kim Lighting's **Architectural Arms** Catalog for complete selection and details.

Structural™ Luminaire with
AA01 - Swept Solid Arm

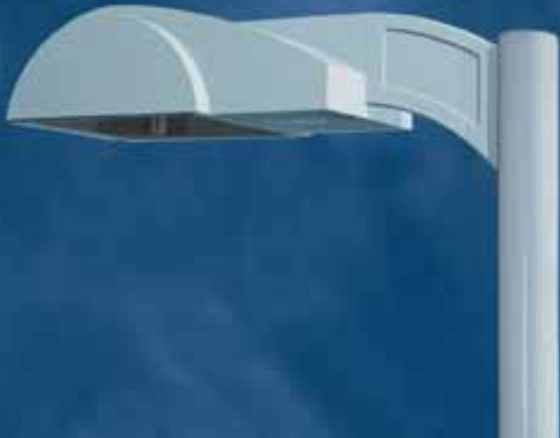

Structural™ Luminaire with
AA03 - Swept Hollow Arm

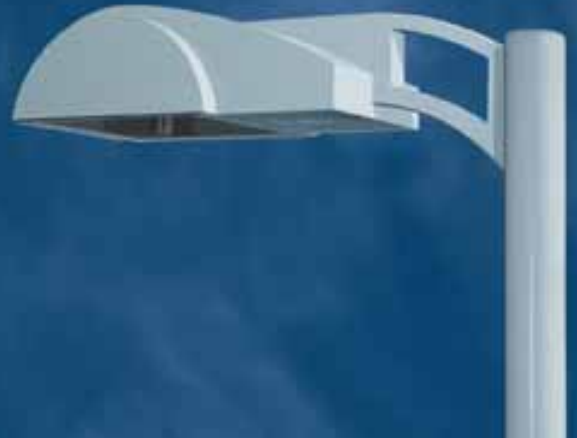

Structural™ Luminaire with
AA05 - Upsweep Solid Arm



Structural™ Luminaire with
AA07 - Upsweep Hollow Arm



Structural™ Luminaire with
AA09 - Uplift Adjustable Arm
(Aluminum)



Structural™ Luminaire with
AA11 - Uplift Adjustable Arm
(Stainless Steel)

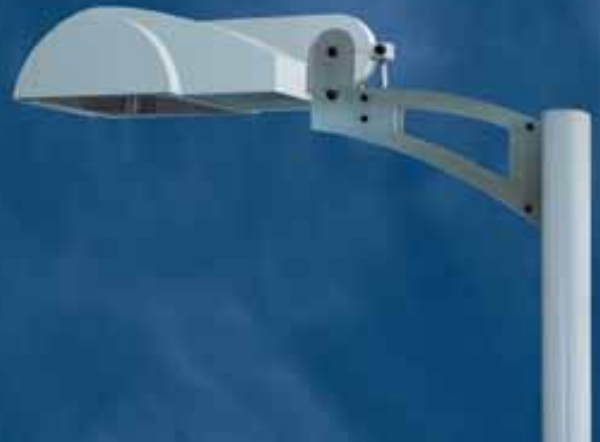

STX (1000W)

Pole Mounted Structural Option Specifications

See pages 12-13 for complete ordering information

TS - Single Tension Rod: Rod has die-cast aluminum clevis which fasten to die-cast aluminum cleats. Fixture cleat is factory mounted. Pole cleat is field mounted and is circular cut for precise mating to round poles. Rod diameter is .500". All fasteners are blackened stainless steel. **TSP** - Structural option rod and clevis detail is finished to match fixture. **TSN** - Structural option rod is stainless steel with nickel plated clevis. All Kim poles are pre-drilled to accept fixture arm and tension rod cleat.

Plan View:



Mounting:	1A	2B	2L	3T	3Y	4C
EPA:	3.6	7.2	4.6	8.2	8.2	8.7

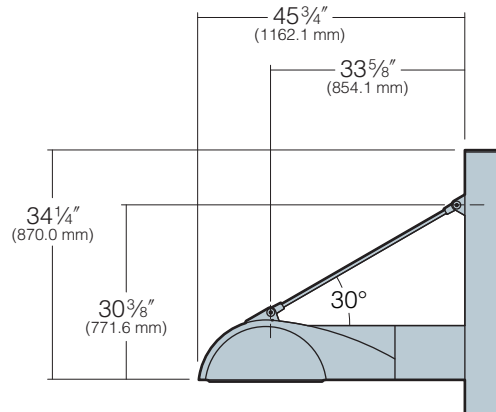

TD - Double Tension Rods: Rods have die-cast aluminum end brackets which fasten to die-cast aluminum cleats. Fixture cleats are factory mounted. Pole cleat is field mounted, and is circular cut for precise mating to round poles. Rod diameter is .500". All fasteners are blackened stainless steel. **TDP** - Structural option rod and clevis details are finished to match fixture. **TDN** - Structural option rod is stainless steel with nickel plated clevis. All Kim poles are pre-drilled to accept fixture arm and tension rod cleats.

Plan View:



Mounting:	1A	2B	2L	3T	3Y	4C
EPA:	3.65	7.3	4.65	8.3	8.3	8.8

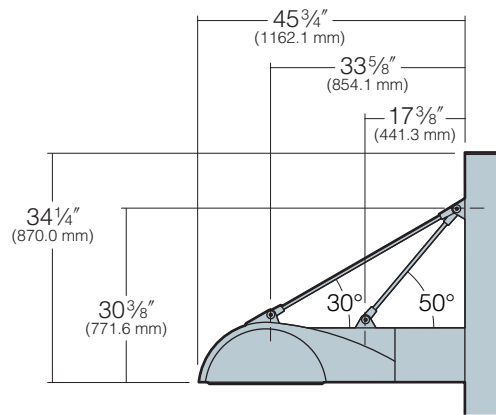

TR - Truss: Cast aluminum truss is fastened to die-cast aluminum cleats. Fixture cleat is factory mounted. Pole cleats are field mounted, and are circular cut for precise mating to round poles. Truss members are 1" square. All fasteners are blackened stainless steel. Structural option is finished to match fixture. All Kim poles are pre-drilled to accept fixture arm and truss cleats.

Plan View:



Mounting:	1A	2B	2L	3T	3Y	4C
EPA:	3.9	7.8	5.2	8.9	8.9	9.7

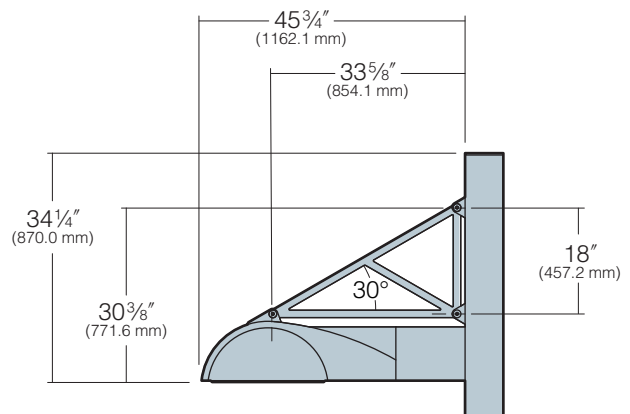

GS - Gusset: Cast aluminum gusset is field mounted to the fixture arm, and circular cut for precise mating to round poles. Gusset is finished to match fixture and arm.

Plan View:



Mounting:	1A	2B	2L	3T	3Y	4C
EPA:	3.75	7.5	4.8	8.55	8.55	9.05

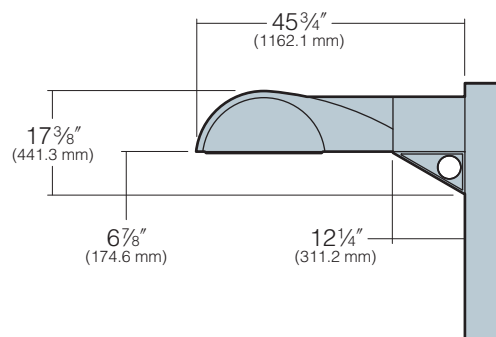

Wall Mount Option Specifications

See pages 12-13 for complete ordering information

Wall Mounting: Modified support arm with side access to allow field splices within the arm, for poured concrete walls only. An electro-zinc plated steel wall embedment bracket is provided to accept draw-bolts. Trim plate provided to cover junction box, finished to match fixture and arm.

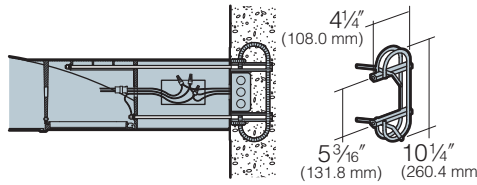

Wall embedment bracket provides 3/8"-16 bolt receptacles welded in a galvanized re-bar cage for casting into poured-in-place concrete walls. Bolt receptacles receive standard draw bolts inside fixture arm, or any 3/8"-16 bolt (by others).

TS-W - Single Tension Rod: Rod has die-cast end brackets which fasten to die-cast aluminum cleats. Fixture cleat is factory mounted. Wall cleat is mounted with two 10-32 stainless steel screws (anchors in wall by others), and includes an aluminum bearing plate. Rod diameter is .500". All fasteners are blackened stainless steel. **TSP-W** - Structural option rod and clevis detail is finished to match fixture. **TSN-W** - Structural option rod is stainless steel with nickel plated clevis.

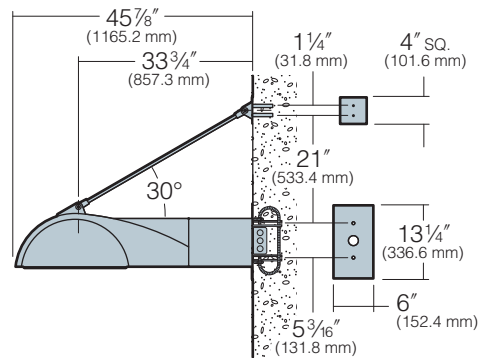

NOTE: To retro-fit existing walls, see wall mounting feature in Architectural Arms Catalog.

TD-W - Double Tension Rods: Rods have die-cast end brackets which fasten to die-cast aluminum cleats. Fixture cleats are factory mounted. Wall cleat is mounted with two 10-32 stainless steel screws (anchors in wall by others), and includes an aluminum bearing plate. Rod diameter is .500". All fasteners are blackened stainless steel. **TDP-W** - Structural option rods and clevis details are finished to match fixture. **TDN-W** - Structural option rods are stainless steel with nickel plated clevis.

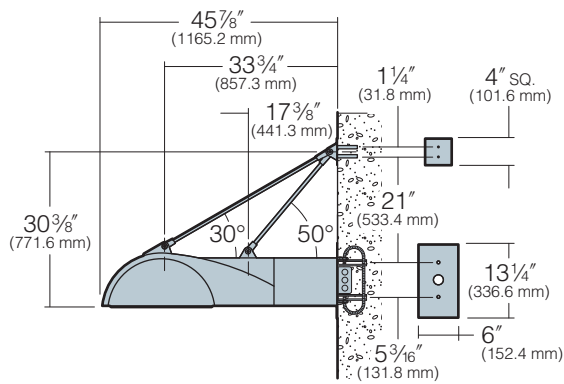

NOTE: To retro-fit existing walls, see wall mounting feature in Architectural Arms Catalog.

TR-W - Truss: Cast aluminum truss is fastened to die-cast aluminum cleats. Fixture cleat is factory mounted. Top wall cleat is mounted with two 10-32 stainless steel screws (anchors in wall by others), and includes an aluminum bearing plate. Lower wall cleat is factory mounted to an extended wall bearing plate. Truss members are 1" square. All fasteners are blackened stainless steel. Structural option is finished to match fixture.

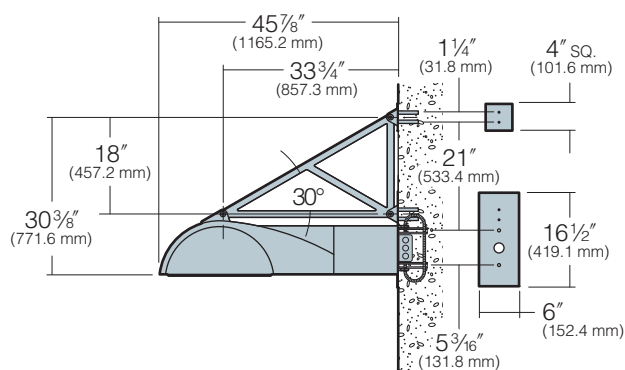

NOTE: To retro-fit existing walls, see wall mounting feature in Architectural Arms Catalog.

GS-W - Gusset: Cast aluminum gusset is field mounted to the fixture arm, and finished to match fixture and arm. An extended wall bearing plate provides visual backing for the gusset.

NOTE: To retro-fit existing walls, see wall mounting feature in Architectural Arms Catalog.

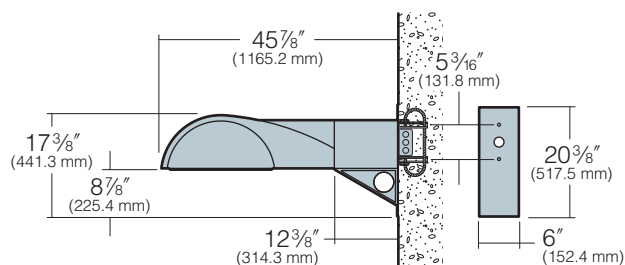

NOTE: Luminaires are designed for downlight aiming only - do not mount inverted, in upright position.

STL (400W) and STS (175W) Pole Mounted Structural Option Specifications

See pages 14-15 and 16-17 for complete ordering information

TS - Single Tension Rod: Rod has die-cast aluminum clevis which fasten to die-cast aluminum cleats. Fixture cleat is factory mounted, and includes a silicone gasket. Pole cleat is field mounted, and is circular cut for precise mating to round poles. Rod diameter is .500" for STL Large Structural, and .406" for STS Small Structural. All fasteners are blackened stainless steel. **TSP** - Structural option rod and clevis detail is finished to match fixture. **TSN** - Structural option rod is stainless steel with nickel plated clevis. All Kim poles are pre-drilled to accept fixture arm and tension rod cleat.

Plan View:



Mounting:	1A	2B	2L	3T	3Y	4C
STL EPA:	2.3	4.6	2.9	5.2	5.2	5.5
Mounting:	1SA	2SB	2SL	3ST	3SY	4SC
STS EPA:	1.2	2.4	1.6	2.8	2.8	2.9

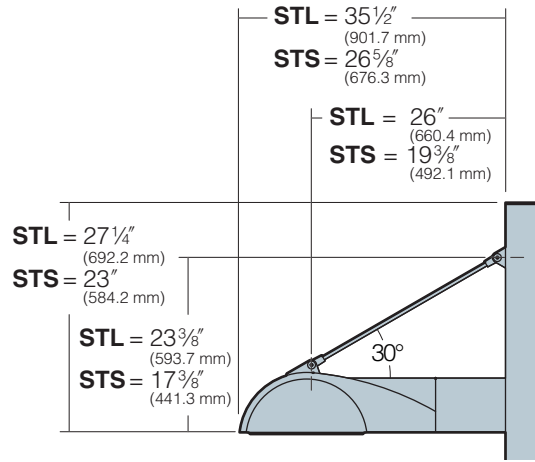

TD - Double Tension Rods: Rods have die-cast aluminum end brackets which fasten to die-cast aluminum cleats. Fixture cleats are factory mounted, and include silicone gaskets. Pole cleat is field mounted, and is circular cut for precise mating to round poles. Rod diameter is .500" for STL Large Structural, and .406" for STS Small Structural. All fasteners are blackened stainless steel. **TDP** - Structural option rod and clevis details are finished to match fixture. **TDN** - Structural option rod is stainless steel with nickel plated clevis. All Kim poles are pre-drilled to accept fixture arm and tension rod cleats.

Plan View:



Mounting:	1A	2B	2L	3T	3Y	4C
STL EPA:	2.35	4.7	2.95	5.3	5.3	5.6
Mounting:	1SA	2SB	2SL	3ST	3SY	4SC
STS EPA:	1.25	2.5	1.65	2.9	2.9	3.0

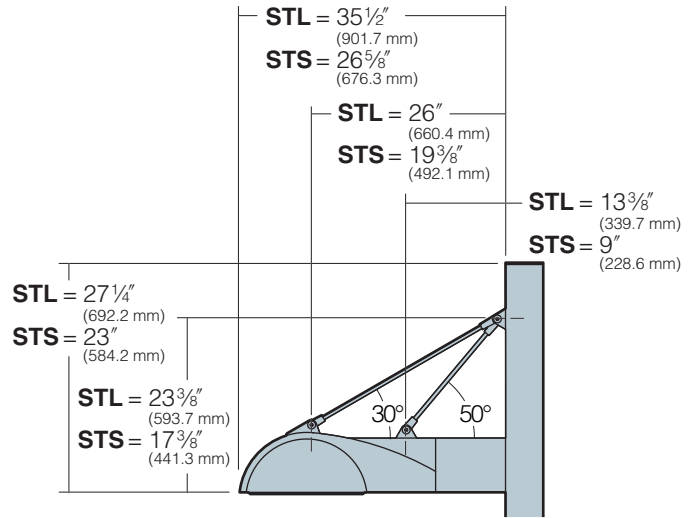

TR - Truss: Cast aluminum truss is fastened to die-cast aluminum cleats. Fixture cleat is factory mounted, and includes a silicone gasket. Pole cleats are field mounted, and are circular cut for precise mating to round poles. Truss members are 1" square for STL Large Structural, and 3/4" square for STS Small Structural. All fasteners are blackened stainless steel. Structural option is finished to match fixture. All Kim poles are pre-drilled to accept fixture arm and truss cleats.

Plan View:



Mounting:	1A	2B	2L	3T	3Y	4C
STL EPA:	2.6	5.2	3.3	5.9	5.9	6.2
Mounting:	1SA	2SB	2SL	3ST	3SY	4SC
STS EPA:	1.4	2.8	1.9	3.3	3.3	3.4

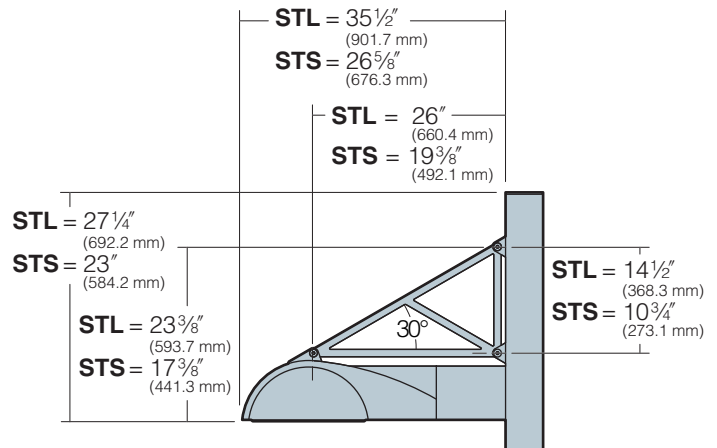

GS - Gusset: Cast aluminum gusset is field mounted to the fixture arm, and circular cut for precise mating to round poles. Gusset is finished to match fixture and arm.

Plan View:



Mounting:	1A	2B	2L	3T	3Y	4C
STL EPA:	2.45	4.9	3.1	5.55	5.55	5.85
Mounting:	1SA	2SB	2SL	3ST	3SY	4SC
STS EPA:	1.25	2.5	1.7	2.95	2.95	3.05

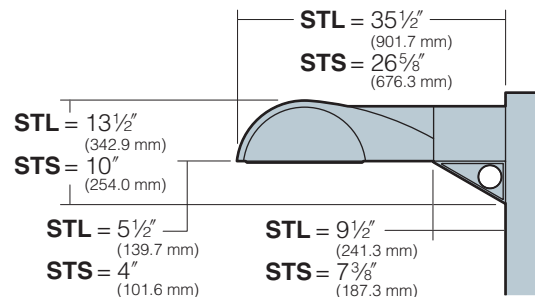

STL (400W) and STS (175W) Wall Mount Option Specifications

See pages 14-15 and 16-17 for complete ordering information

Wall Mounting: Modified support arm with side access to allow field splices within the arm, for poured concrete walls only. An electro-zinc plated steel wall embedment bracket is provided to accept draw-bolts. Trim plate provided to cover junction box, finished to match fixture and arm.

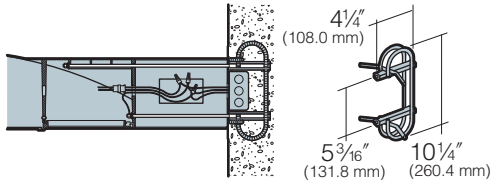

Wall embedment bracket provides 3/8"-16 bolt receptacles welded in a galvanized re-bar cage for casting into poured-in-place concrete walls. Bolt receptacles receive standard draw bolts inside fixture arm, or any 3/8"-16 bolt (by others).

TS-W - Single Tension Rod: Rod has die-cast end brackets which fasten to die-cast aluminum cleats. Fixture cleat is factory mounted, and includes a silicone gasket. Wall cleat is mounted with two 10-32 stainless steel screws (anchors in wall by others), and includes an aluminum bearing plate. Rod diameter is .500" for STL Large Structural, and .406" for STS Small Structural. All fasteners are blackened stainless steel. **TSP-W** - Structural option rod and clevis detail is finished to match fixture. **TSN-W** - Structural option rod is stainless steel with nickel plated clevis.

NOTE: To retro-fit existing walls, see wall mounting feature in Architectural Arms Catalog.

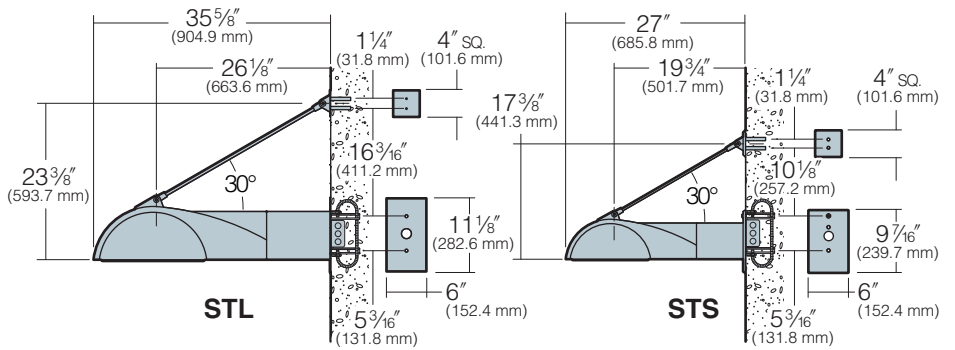

TD-W - Double Tension Rods: Rods have die-cast end brackets which fasten to die-cast aluminum cleats. Fixture cleats are factory mounted, and include silicone gaskets. Wall cleat is mounted with two 10-32 stainless steel screws (anchors in wall by others), and includes an aluminum bearing plate. Rod diameter is .500" for STL Large Structural, and .406" for STS Small Structural. All fasteners are blackened stainless steel. **TDP-W** - Structural option rods and clevis details are finished to match fixture. **TDN-W** - Structural option rods are stainless steel with nickel plated clevis.

NOTE: To retro-fit existing walls, see wall mounting feature in Architectural Arms Catalog.

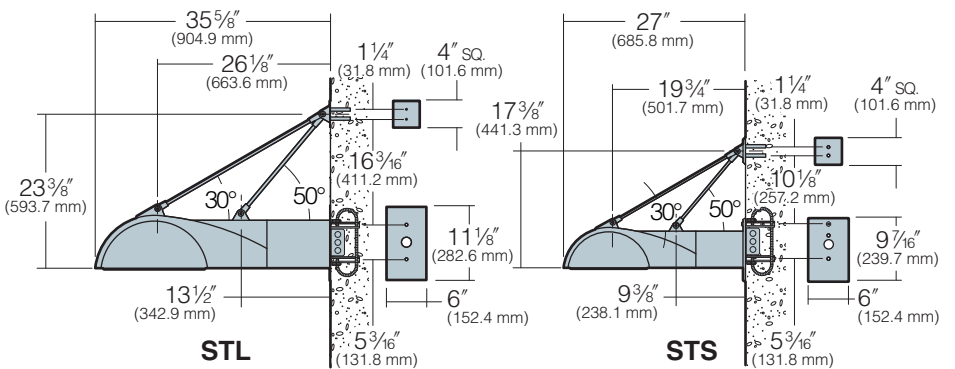

TR-W - Truss: Cast aluminum truss is fastened to die-cast aluminum cleats. Fixture cleat is factory mounted, and includes a silicone gasket. Top wall cleat is mounted with two 10-32 stainless steel screws (anchors in wall by others), and includes an aluminum bearing plate. Lower wall cleat is factory mounted to an extended wall bearing plate. Truss members are 1" square for STL Large Structural, and 3/4" square for STS Small Structural. All fasteners are blackened stainless steel. Structural option is finished to match fixture.

NOTE: To retro-fit existing walls, see wall mounting feature in Architectural Arms Catalog.

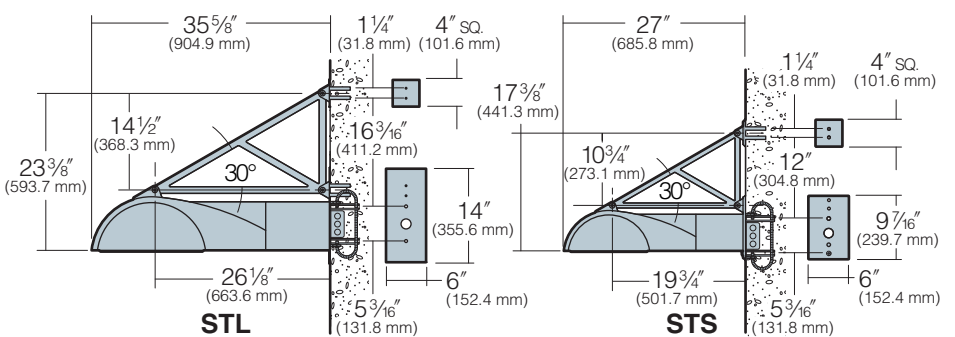

GS-W - Gusset: Cast aluminum gusset is field mounted to the fixture arm, and finished to match fixture and arm. An extended wall bearing plate provides visual backing for the gusset.

NOTE: To retro-fit existing walls, see wall mounting feature in Architectural Arms Catalog.

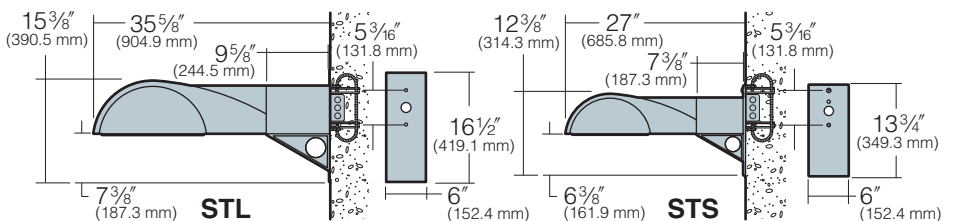

NOTE: Luminaires are designed for downlight aiming only - do not mount inverted, in upright position.



Proportion Guide

70 to 1000 Watt / 10' to 39' Poles

40'

38'

36'

34'

32'

30'

28'

26'

24'

22'

20'

18'

16'

14'

12'

10'

8'

6'

4'

2'

GRADE

This proportion diagram is intended to help visualize and select the best Structural™ models to satisfy aesthetic requirements. Remember, the pole height also affects performance; the higher the fixture is mounted, the greater the light throw. If poles are mounted on concrete pedestals such as in parking lots, the height of the pedestal must be considered in selecting the pole height.

See Architectural Arms Catalog for proportion drawings of Structural luminaire with optional Architectural Arms.

STL Models:
150 to 400 Watt
19½' to 30' poles

STX Models:
600 to 1000 Watt
35' to 39' poles

8.5" x 3.6"
Tapered
Pole

9" x 3.5"
Tapered
Pole

STS Models:
70 to 175 Watt
10' to 16' poles

3⅜"

3⅜"

4"

4"

5"

6"

6"



Lamp and Electrical Guide³

Lamp Watts	Lamp Type	System Watt	Bulb Type	Initial Lumens	Life (Hours)	ANSI Code	Starting Temp	Circuit Type	Voltage	Operating Amps.	Open Circuit Amps.	Starting Amps.	Min. Fuse Amps.
PULSE START METAL HALIDE													
50	PMH	67	Clear, ED17, Medium Base	4000	20000+	M110 M148	-30C	HX-HPF	120	0.62	1.16	0.87	2
									208	0.40	0.67	0.51	1
									240	0.35	0.57	0.47	1
									277	0.32	0.50	0.32	1
									347	0.24	0.48	0.21	1
70	PMH	90	Clear, ED17, Medium Base	6200	16000	M98 M143	-30C	HX-HPF	120	0.85	1.90	0.80	4
									208	0.52	1.00	0.50	3
									240	0.44	0.90	0.43	2
									277	0.39	0.80	0.39	2
									347	0.28	0.70	0.20	2
100	PMH	129	Clear, ED17, Medium Base	9000	16000	M140	-30C	HX-HPF	480*	0.23	0.50	0.26	2
									120	1.15	2.30	1.20	6
									208	0.66	1.40	0.80	4
									240	0.58	1.15	0.65	3
									277	0.50	1.00	0.60	3
150	PMH	185	Clear, ED17, Medium Base	14000	16000	M102 M142	-30C	HX-HPF	347	0.40	1.00	0.40	2
									480*	0.30	0.55	0.30	2
									120	1.60	3.65	1.75	10
									208	1.00	2.10	1.30	5
									240	0.80	1.80	0.85	5
200	PMH	240	Clear, T15, Mogul Base	19000	15000	M136	-30C	Super CWA	277	0.70	1.58	0.77	4
									347	0.55	1.25	0.65	3
									480*	0.42	0.81	0.45	3
									120	2.00	2.00	0.75	6
									208	1.20	1.20	0.40	4
250	PMH	295	Clear, BT28, Mogul Base	22500	11250	M138 M153	-30C	CWA	240	1.00	1.00	0.35	3
									277	0.85	0.85	0.30	3
									347	0.70	0.65	0.25	2
									480	0.50	0.50	0.18	2
									120	2.50	1.40	2.30	8
320	PMH	368	Clear, BT28, Mogul Base	30000	20000	M132 M154 M170	-30C	Super CWA	208	1.45	0.80	1.30	5
									240	1.25	0.70	1.15	5
									277	1.10	0.60	1.00	3
									347	0.95	0.75	0.45	3
									480	0.57	0.48	0.21	2
350	PMH	400	Clear, BT28, Mogul Base	33000	20000	M131 M171	-30C	Super CWA	120	3.25	2.30	1.80	8
									208	1.90	1.35	1.05	6
									240	1.65	1.15	0.90	5
									277	1.40	1.00	0.80	3
									347	1.10	0.80	0.70	3
400	PMH	452	Clear, BT28, Mogul Base	40000	20000	M135 M155 M172	-30C	Super CWA	480	0.80	0.60	0.45	5
									120	4.00	2.20	3.50	10
									208	2.30	1.50	2.00	7
									240	2.00	1.10	1.75	5
									277	1.75	0.95	1.50	5
750	PMH	820	Clear, BT37, Mogul Base	68000	12000+	M149	-30C	CWA	347	1.35	0.75	1.10	4
									480	1.00	0.60	0.75	3
									120	7.00	3.60	5.60	20
									208	4.00	2.00	3.30	10
									240	3.50	1.80	2.80	10
1000	PMH	1080	Clear, BT37, Mogul Base	107800	9000+	M141	-30C	CWA	277	3.00	1.80	2.20	8
									347	2.45	1.45	1.65	7
									480	1.75	1.00	1.25	5
									120	9.00	4.50	7.80	20
									208	5.20	2.70	4.00	15
METAL HALIDE													
175	MH	210	Clear, ED17, Medium Base Clear, BT28, Mogul Base	14400 15000	7000 10000+	M57 M57	-30C	CWA	240	0.90	0.90	0.65	3
									277	0.80	0.80	0.55	2
									347	0.65	0.65	0.50	2
									480*	0.45	0.45	0.35	2
									120	2.60	2.60	1.00	8
250	MH	295	Clear, BT28 or ED18 Mogul Base	23000	7000	M58	-30C	CWA	208	1.50	1.50	0.60	5
									240	1.30	1.30	0.50	5
									277	1.10	1.10	0.45	3
									347	0.85	1.05	0.35	3
									480	0.65	0.65	0.30	2
400	MH	458	Clear, BT28, Mogul Base	40000	15000	M59	-30C	CWA	120	4.50	3.20	2.50	10
									208	2.30	1.80	1.40	7
									240	2.00	1.60	1.20	5
									277	1.70	1.50	1.00	5
									347	1.35	1.35	0.80	4
1000	MH	1080	Clear, BT37, Mogul Base	107800	9000+	M47	-30C	CWA	480	1.00	0.75	0.90	3
									120	9.00	4.50	7.80	20
									208	5.20	2.70	4.00	15
									240	4.50	2.30	3.70	10
									277	3.90	2.20	3.20	10
									347	3.20	1.70	2.50	8
									480	2.25	1.20	1.90	6

Lamp and Electrical Guide¹

Lamp Watts	Lamp Type	System Watt	Bulb Type	Initial Lumens	Life (Hours)	ANSI Code	Starting Temp	Circuit Type	Voltage	Operating Amps.	Open Circuit Amps.	Starting Amps.	Min. Fuse Amps.
HIGH PRESSURE SODIUM													
70	HPS	91	Clear, ED17, Medium Base	6300	24000	S62	-40C	HX-HPF	120	0.81	1.45	0.75	6
									208	0.47	0.85	0.45	4
									240	0.40	0.75	0.37	3
									277	0.35	0.65	0.35	3
									347	0.30	0.55	0.30	2
									480 ⁴	0.21	0.36	0.21	2
100	HPS	130	Clear, ED17, Medium Base	9500	24000	S54	-40	HX-HPF	120	1.15	2.20	1.30	7
									208	0.67	1.25	0.75	5
									240	0.58	1.10	0.65	3
									277	0.50	0.85	0.60	3
									347	0.39	0.70	0.45	3
									480 ⁴	0.29	0.55	0.21	3
150	HPS	188	Clear, ED17, Medium Base Clear, E18, Mogul Base	16000 20000	24000 24000	S55 S55	-40	HX-HPF	120	1.65	2.80	2.00	10
									208	0.95	1.60	1.15	5
									240	0.83	1.40	1.00	5
									277	0.72	1.25	0.85	4
									347	0.56	0.92	0.52	3
									480 ⁴	0.42	0.70	0.50	2
250	HPS	295	Clear, E18, Mogul Base	29000	24000	S50	-40	CWA	120	2.50	1.70	1.65	7
									208	1.50	1.00	0.95	4
									240	1.30	0.85	0.80	4
									277	1.10	0.75	0.70	3
									347	0.93	0.70	0.60	2
									480	0.63	0.45	0.40	2
400	HPS	464	Clear, E18, Mogul Base	51000	24000	S51	-40	CWA	120	3.80	2.00	3.30	10
									208	2.20	1.20	1.80	6
									240	1.90	0.95	1.50	5
									277	1.70	0.85	1.40	5
									347	1.32	0.70	1.00	5
									480	0.97	0.55	0.75	3
600	HPS	670	Clear, T16, Mogul Base	90000	24000+	S106	-40	CWA	120	5.50	3.00	5.25	15
									208	3.25	1.75	3.00	9
									240	2.85	1.60	2.60	8
									277	2.50	1.40	2.15	7
									347	2.00	1.10	1.70	5
									480	1.43	0.75	1.20	4
750	HPS	840	Clear, BT37, Mogul Base	110000	24000+	S111	-40	CWA	120	6.75	3.00	6.30	20
									208	4.00	1.75	3.70	10
									240	3.50	1.60	3.20	10
									277	3.10	1.50	3.00	10
									347	2.50	1.20	2.30	10
									480	1.78	0.90	1.65	5
1000	HPS	1100	Clear, E25, Mogul Base	140000	24000+	S52	-40	CWA	120	9.50	4.80	6.40	25
									208	5.50	2.70	3.80	15
									240	4.75	2.40	3.20	10
									277	4.15	2.20	2.80	10
									347	3.30	1.10	2.20	10
									480	2.30	0.90	1.60	6
COMPACT FLUORESCENT													
42	PL	46	Coated, GX24q-4 Base	3200	12000	N/A	-18C	Electronic	120	-	-	0.39	2
									208	-	-	0.23	2
									240	-	-	0.20	2
									277	-	-	0.17	2
									277	-	-	0.17	2
57	PL	59	Coated, GX24q-5 Base	4300	12000	N/A	-10C	Electronic	120	-	-	0.80	2
									208	-	-	0.40	2
									240	-	-	0.20	2
									277	-	-	0.21	2
									277	-	-	0.21	2
60	PL	70	Coated, 2G8-1 Base	4000	20000	N/A	-30C	Electronic	120	-	-	0.59	2
									208	-	-	0.40	2
									240	-	-	0.32	2
									277	-	-	0.26	2
									277	-	-	0.26	2
INDUCTION FLUORESCENT													
55	IF	N/A	Induction Lamp	3500	100000	N/A		Electronic	120	-	-	-	2
									208	-	-	-	2
									240	-	-	-	2
									277	-	-	-	2
									277	-	-	-	2
85	IF ²	N/A	Induction Lamp	6000	100000	N/A		Electronic	120	-	-	-	3
									208	-	-	-	3
									240	-	-	-	3
									277	-	-	-	3
									277	-	-	-	3

¹ Multiple CFL lamp configurations (ie, two 42W lamps) are possible with certain optical systems. Consult factory for details.

² 85W IF lamps available for STL only.

³ Lamp and electrical data supplied for reference purposes only. All initial lumen values shown may vary from one manufacturer to another. Consult lamp manufacturer's data for exact lumen and life data.

⁴ 480 volt with medium base lamp sockets may require approval by the local building code authority.

WARNING: Fixtures must be installed and grounded in accordance with national, state and/or local electrical codes. Failure to do so may result in serious personal injury.

For lamp/ballast information outside of the U.S.A. and Canada, please consult your local Kim representative.

Lamps by others.

Structural™

F U L L C u t o f f L u m i n a i r e



Because of a continuing product improvement program, Kim Lighting reserves the right to change specifications without notice.

How may we serve you better?
Let us know by visiting our web site at:
www.kimlighting.com

Your input is valuable to us.



KIM LIGHTING

www.kimlighting.com

