

Era[®]

Heritage Style Luminaire

70 - 400 Watt



KIM LIGHTING

Heritage Style Cutoff Luminaires

Table of Contents

Relativity	2-3
Style and Performance	4
Integrated Design	6
Design Features	8-9
Optical System Features	10-11
Mounting Configurations	12-13
Luminaire	
Ordering Information	16-17
Luminaire Specifications	18
Option Specifications	19
Options for Wall Mounting	20
Integrated Pole Ordering Information / Specifications	22-27
Wind Map	28
Proportion Guide	29
Lamp and Electrical Guide	30-31
Application Engineering Services	31



SITE / AREA
PARKING STRUCTURE
ROADWAY
ARCHITECTURAL FLOOD
ACCENT
LANDSCAPE

MAILING ADDRESS:
P.O. BOX 60080
CITY OF INDUSTRY, CA
91716-0080

BUSINESS ADDRESS:
16555 EAST GALE AVENUE
CITY OF INDUSTRY, CA 91745
U.S.A.

PHONE 626 / 968 - 5666
FAX 626 / 369 - 2695

ENTIRE CONTENTS
© COPYRIGHT 2010 KIM LIGHTING, INC.
ALL RIGHTS RESERVED
REPRODUCTION IN WHOLE OR IN PART
WITHOUT PERMISSION IS STRICTLY PROHIBITED.
U.S. PATENT D430,687

www.kimlighting.com



HUBBELL LIGHTING, INC.

Printed in U.S.A.
5503310306
Version 1.1 (11/10)



Era®

Inspired by the growth of the "Heritage Style" in design, the Era adds a new dimension to applying the superior performance of Kim optical systems.

Optically identical to other Kim Site / Roadway systems, the Era offers an alternative to rectilinear shapes, without compromising performance.

A wide range of integrated pole designs further expands application flexibility.

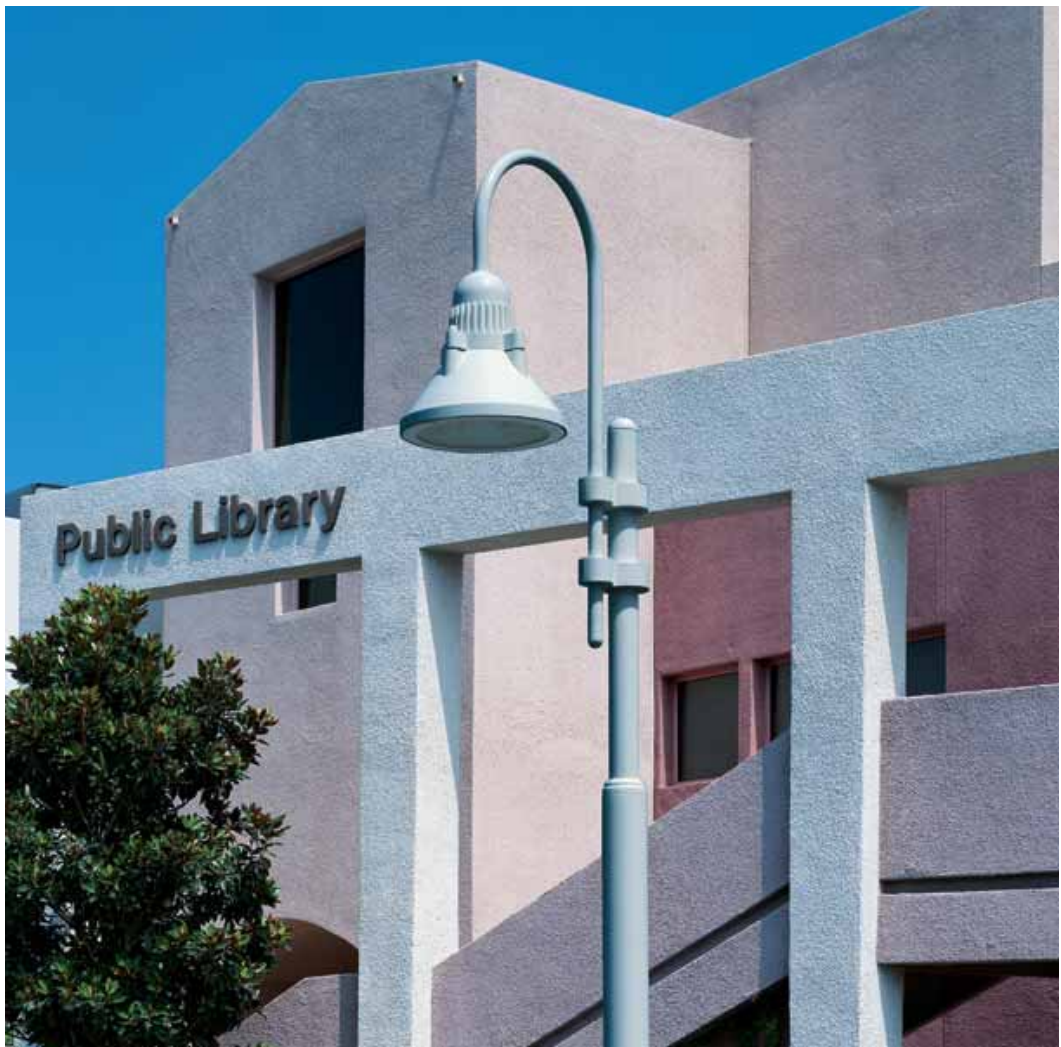



Kim Lighting's Theory of Relativity

The Relationship of Outdoor Lighting to Site and Architecture



RA25 Large Era®



RA17 Small Era®



VRB Vandal Resistant Bollard



LTV Lightvault®

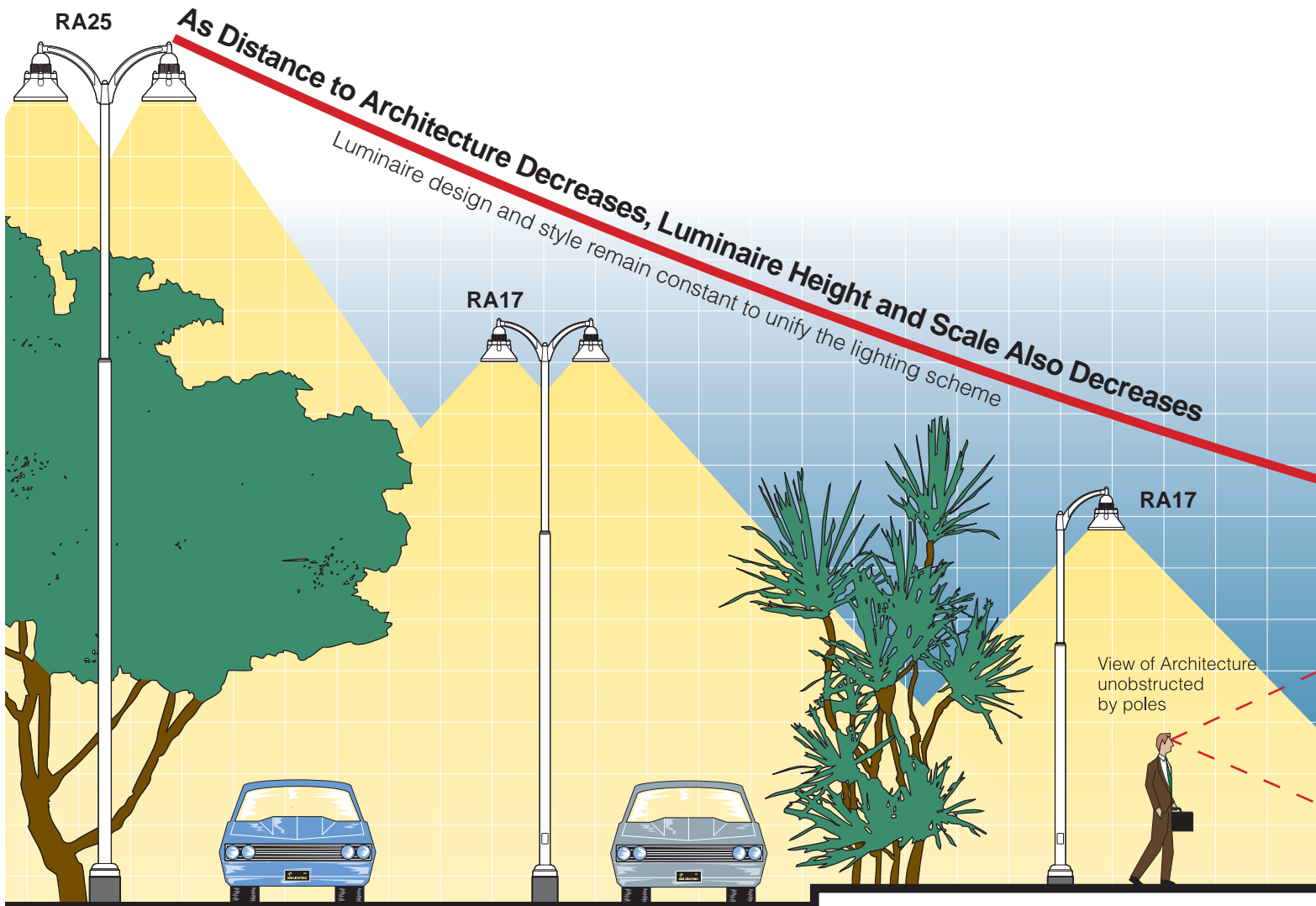

SITE / ROADWAY ZONE

Parking lots and roadways require luminaires on 20' - 40' poles to efficiently light these large areas. Therefore, this lighting becomes dominant and sets the design and style for all other lighting as you progress towards the building.

PEDESTRIAN ZONE

As you leave the parking lot and transition to pedestrian areas, poles should decrease in height to 10' - 16'. In addition, luminaires should decrease in scale, and can have more decorative features to be appreciated at the pedestrian level.



AFL Architectural Floodlight



WF Wall Forms®



WF Wall Forms®



WD Wall Director®

KIM LIGHTING'S THEORY OF RELATIVITY

The purpose of this guideline is to bring a cohesive look to outdoor lighting, maximizing lighting efficiency while preserving the architectural experience. Simply stated, the Kim Theory of Relativity says "Poles belong in parking lots. And, once you leave the parking lot, the outdoor lighting should become less and less conspicuous until it becomes an integral part of the architecture." In addition, the luminaire style and geometry should remain consistent. If this guideline is utilized, the outdoor lighting will enhance the site and architecture, bringing unity to the outdoor lighting scheme.

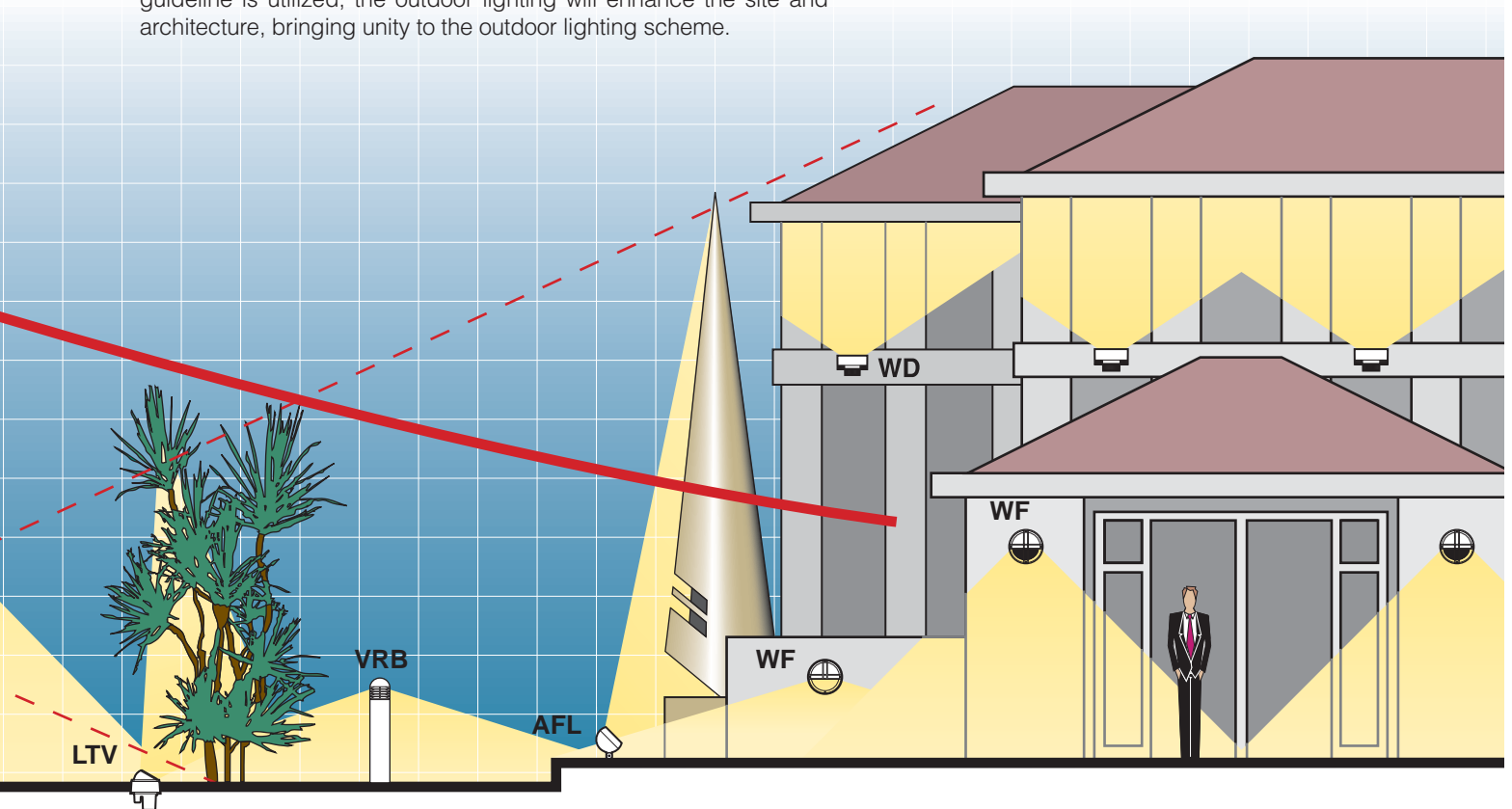

LANDSCAPE / PATH ZONE

Near the building, luminaires should begin to disappear, blending into the landscape and hardscape elements.

BUILDING / PERIMETER ZONE

No pole mounted luminaires should ever be used near the building, as they will dominate the architecture. The only exception would be the use of decorative luminaires to delineate entrances to the structure. Building mounted, architecturally compatible fixtures should be almost invisible.

Style and Performance

Aesthetics without Compromise

Approach

Unlike most Kim product innovations that have a singular design theme, Era[®] is unique. We wanted to develop a luminaire that was equally at home in either a traditional or contemporary setting; an international style fixture capable of establishing a visual unity with many architectural themes. To accomplish this, Era combines basic design elements of both traditional and contemporary luminaires, skillfully orchestrated into a cohesive product design with appealing proportions and elegant detailing.

Era incorporates Kim's most up-to-date optical systems, with four horizontal lamp reflectors and two vertical lamp reflectors. Sacrificing performance to include style of this caliber is no longer required.

Performance

In every respect, Era is optically equal to any Kim Site / Roadway luminaire. The reflectors used are the same as those available in the extensive Kim Site / Roadway product line. Incorporating fully rotatable orientation and sealed optical chambers, Era offers an alternative to rectilinear designs without sacrificing illumination performance.

Robust Components

Castings and extrusions are used to produce precise and durable detailing. Tight fitment and rigid construction insure clean component attachment and tight sealing against intrusion of contaminants.

1W Wall Mount arm not included and must be ordered separately. See p. 20 for ordering.





Integrated Design

Complementary Detailing

Integration

Era design approaches all detailing as integral pieces of the whole. From the use of its clean bell shape for the Optical Housing and exposed cooling surfaces on the Ballast Housing, to the detailing of the mounting arms and poles, Era is complete.

Combining proven mechanical features with a highly styled package without sacrificing either performance or aesthetic design is a difficult task. Era answers this challenge, with flexibility to satisfy a wide range of architectural tastes.

The luminaire, mounting arms, and poles were developed with shared detailing and complementary mating components. This approach produces a complete design that is robust in style and mechanical integrity.

HA01S/HA01L

Post Top Crook Arm



HA02S/HA02L

Side Mount Crook Arm



HA03S/HA03L

Post Top Swept Cast Arm



1W Wall Mount



RA17 shown with **HA02SW** wall mount option. Wall mount arm is **not** included and must be ordered separately. See page **20** for ordering.



Design Features

Precision and Durability

Die-Cast Aluminum Components

The Era housing and door frame are die-cast, low copper (<0.6%) aluminum for precision and repeatability. The two piece housing is reinforced and sealed with a continuous O-ring silicone gasket.



The precision of die-casting produces clean detailing and elegant proportions. Ballast housing ribs aid component cooling.



Die-cast lower body produces durable, smooth detail. Rigid component insures trouble free seal to ballast housing.



The door frame is extra rigid for dependable sealing of the optical chamber through uniform gasket pressure.

Extruded Aluminum Arms



The crook arms are formed from an aluminum extrusion specifically designed to dampen oscillations due to wind. The structural integrity of this extrusion also resists the "sagging" look that develops from vibration and weight, commonly found in other luminaires of this type.

Durable Powder Coat Finish

Kim's state-of-the-art powder coat paint system is engineered to provide the highest quality finish with absolute paint adhesion under weather extremes. The Super TGIC thermoset polyester powder coat finish is applied over a titanated zirconium conversion coating. This finish system exceeds the A.S.T.M. 1000 hour salt spray test, enduring over 2500 hours without failure.

Eight Stage Finish

1. Power wash and degrease.
2. Detergent tank bath.
3. Clear water rinse bath.
4. Premium Titanated Zirconium conversion coating as used in the automobile industry.
5. Clear water rinse bath.
6. Dry off oven.
7. Powder coating, 2.5 mil nominal thickness.
8. Bake for 20 minutes at 410°F.

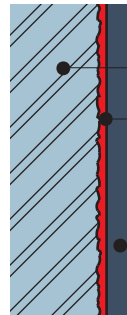

Standard Super TGIC Colors

- BL Black
- DB Dark Bronze
- SG Stealth Gray™
- LG Light Gray
- PS Platinum Silver
- WH White

Strong Universal Mount

Era luminaires incorporate a strong double-bolt mount, universal to every arm configuration.

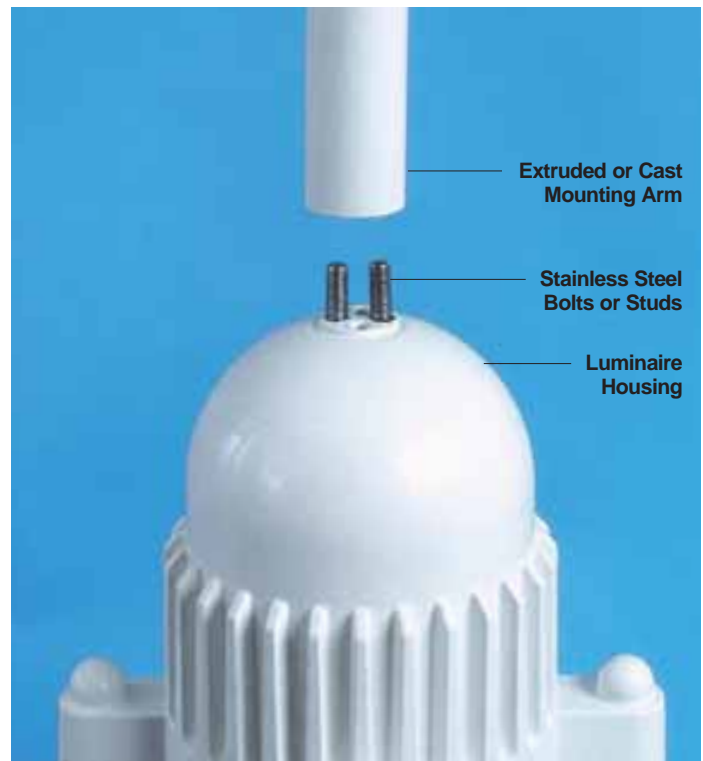

Sealed Optical System

The optical compartment is completely sealed from outside and inside including wire entries to the socket. The tempered clear glass lens is sealed by molded silicone gaskets at the optical compartment. By eliminating the intrusion of moisture, dust, and insects, the efficiency of the optical system is maintained. This assures maximum light output between standard maintenance intervals.

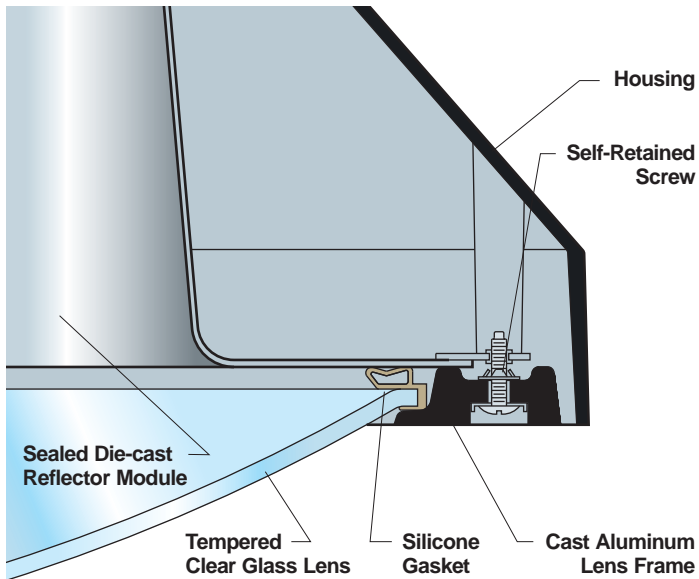

Optional Glow Ring

The optional glow ring receives illumination from a sealed window in the optical system. This produces just the right amount of accent light, while maintaining the integrity of the sealed optical chamber.



Ventilated Ballast Compartment

The ballast housing of the Era luminaire draws ventilation air from around the sealed optical assembly to maintain the lowest possible operating temperature.

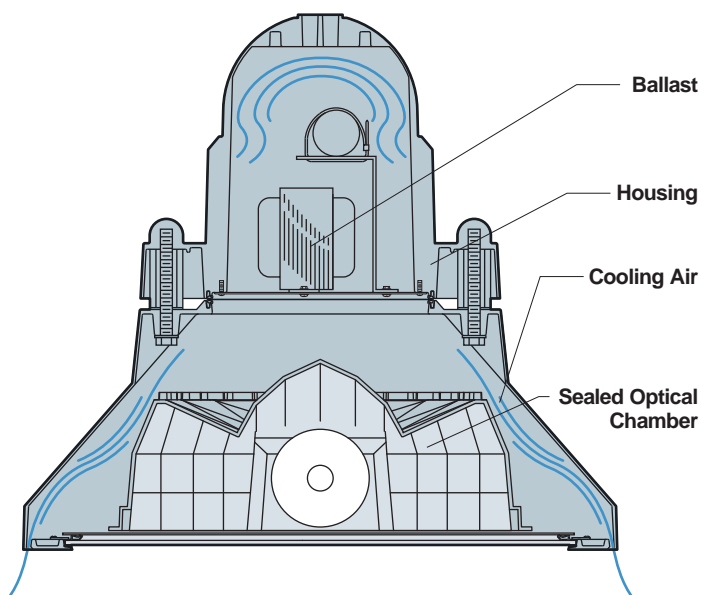

Optical System Features

Horizontal or Vertical Lamp

See the **Kim Site / Roadway Optical Systems Catalog** for complete details and explanation of optical system features.

Horizontal Lamp

Available in **Type II, Type III, Type IV,** and **Type V Square** distributions. This flat lens system provides **full cutoff control** and very good uniformity.

Sealed optics and performance reflector technology allow this horizontal lamp optical system to maximize lamp output. An optional houseside shield is available for Types II, III, and IV distributions.

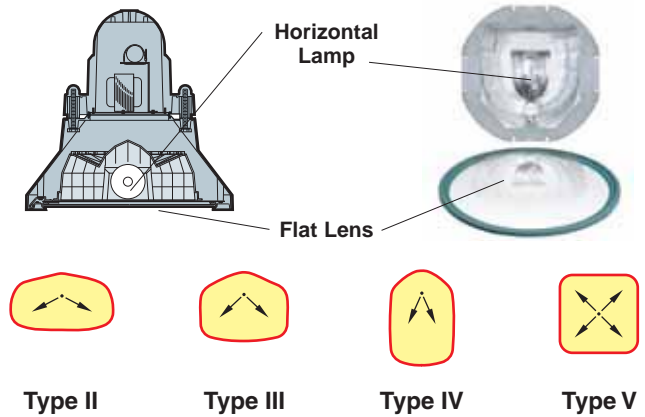

Optional Convex Lens

An optional convex lens offers increased lens presence, a subtle improvement in uniformity and increased effectiveness of houseside shielding.

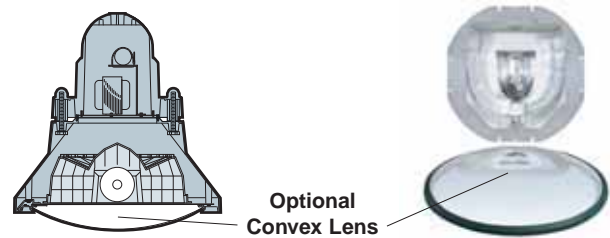

Vertical Lamp

Available in **Asymmetric** and **Symmetric** distributions in wide range. Provides vertical lamp performance in a compact luminaire profile with excellent uniformity.

The reflector utilizes Kim's split beam reflector technology, optimizing lamp output and life (see below). An optional houseside shield is available for the Asymmetric distribution.

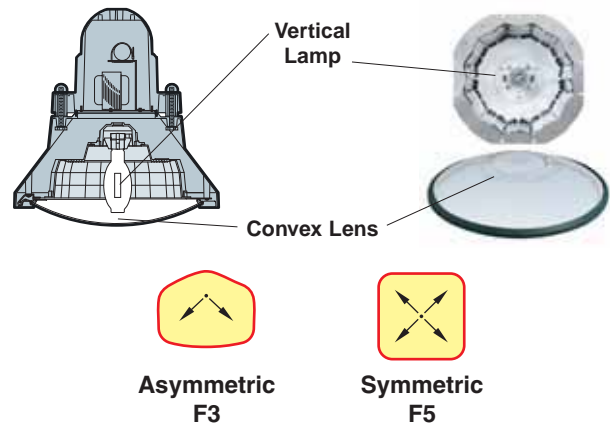

Split Beam Reflector Geometry

Wide-beam vertical lamp reflectors will redirect light back into the lamp unless properly designed. Kim reflectors are precision engineered to avoid this by using split-beam reflector geometry.

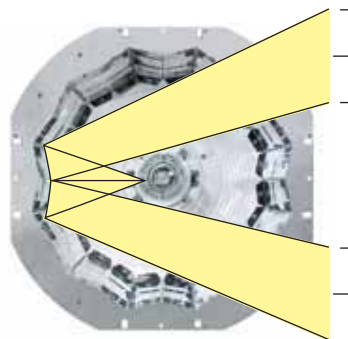

Reflected light does not pass through the lamp envelope, which otherwise will reduce lamp life and efficiency.

Split beams of reflected light pass freely and efficiently out of the luminaire.

Rotatable Optics

All asymmetric reflectors are field rotatable in 90° increments. This allows design flexibility in producing very high illumination levels for special applications or for maintaining a consistent fixture orientation throughout the site. To facilitate field rotation, each reflector is labeled to show the orientation of the light pattern.



Horizontal Lamp

Type II
Type III
Type IV



Vertical Lamp

Asymmetric
F3

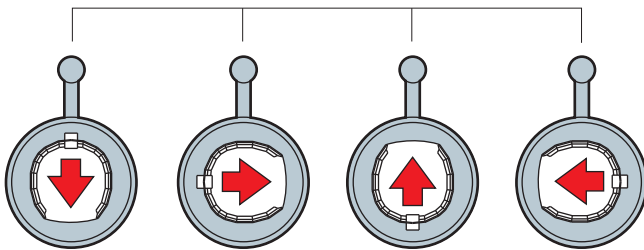

Rotatable reflectors offer a degree of refinement in fixture orientation when the architecture and site demand perfection.

When the twin-mounted luminaires are used for site lighting using Types II, III or IV distributions, the combined effect from the twin mount is a rectangular light pattern.

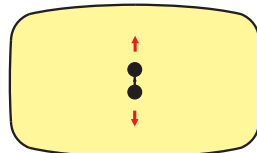

To change the orientation of the rectangular pattern, you normally change the orientation of the twin mount. An alternative to this is shown at right, where the fixture orientation remains constant and the internal reflectors rotate to change the orientation of the rectangular light pattern. This can maintain identical fixture orientations throughout the site.

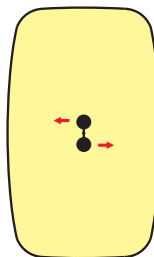

For applications demanding high light levels, such as tennis courts and automobile dealerships, reflectors can be rotated in parallel to double the light levels. Houseside shields can be added to the fixtures for reducing spill light into unwanted areas behind the luminaires. See page 19.

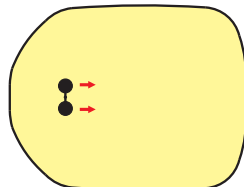

Cutoff Control

Luminaires with good cutoff characteristics produce less light pollution and distribute a greater portion of their output into usable lighting zones. This is not only more efficient, it produces a more conscientious and environmentally friendly lighting design.

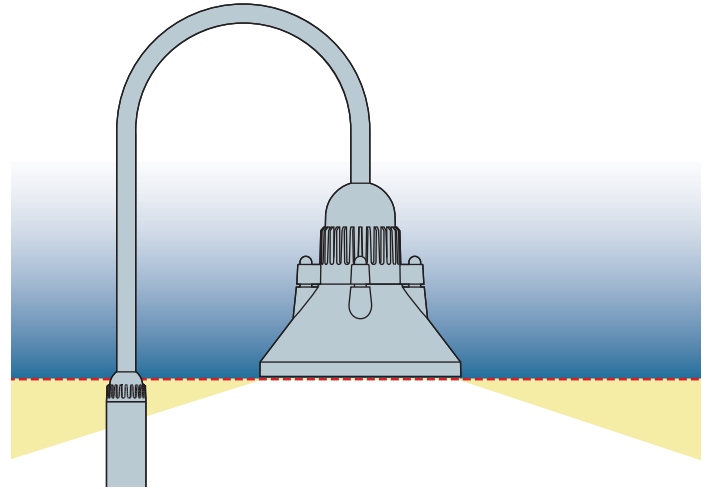

Mounting Configurations

Crook Arms

HA01S/HA01L

Post Top Crook Arm

Extruded Crook Arm

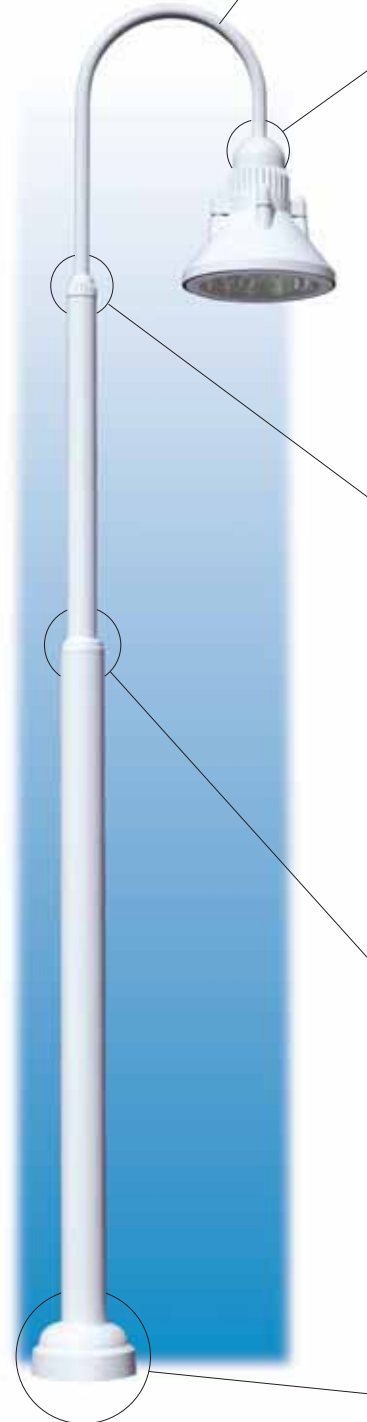

The luminaire head is bolted to the crook arm with two large stainless steel bolts.



The crook arm slip fits and is bolted into the pole top.



The pole step transition is reinforced and fully welded.

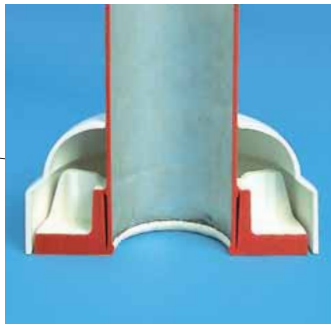

Available Configurations



1A

HA02S/HA02L

Side Mount Crook Arm

Extruded Crook Arm

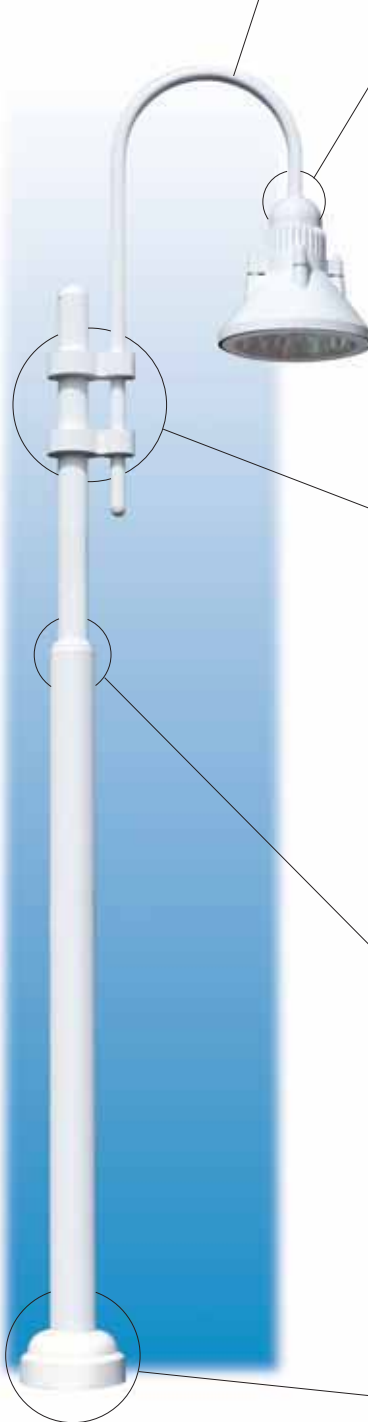

The luminaire head is bolted to the crook arm with two large stainless steel bolts.

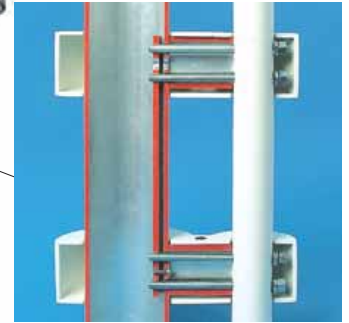

The crook arm is securely bolted to the pole under decorative covers.



The pole step transition is reinforced and fully welded.

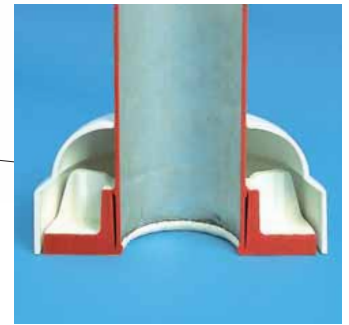

Available Configurations



1W



1A



2B



3Y



4C

The pole base is double welded and includes a full cast cover.

Swept Arm

HA03S/HA03L
 Post Top Swept Cast Arm
 Heavy Cast Arm

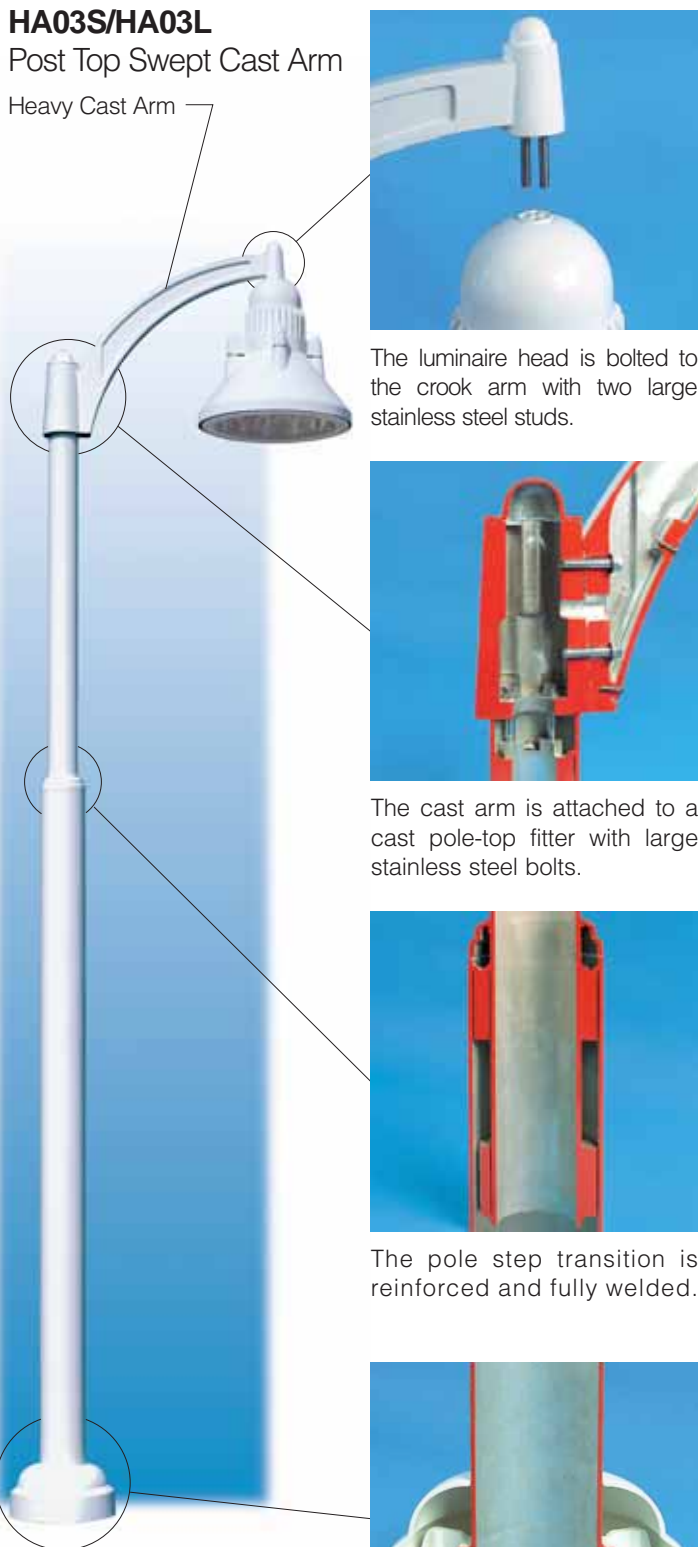

The luminaire head is bolted to the crook arm with two large stainless steel studs.



The cast arm is attached to a cast pole-top fitter with large stainless steel bolts.







The pole step transition is reinforced and fully welded.



The pole base is double welded and includes a full cast cover.

Available Configurations

- | | |
|---|---|
|  |  |
| 1A | 2B |
|  |  |
| 3Y | 4C |







Luminaire Ordering Information

Era® Series

RA17
70 to 175 Watt
RA25
150 to 400 Watt

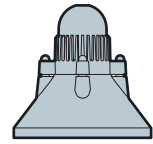

Ordering Example:

For Standard Fixture and Pole

Mounting Fixture Electrical Module Finish Options Pole Optional Arm Pole & Arm Finish

1A/RA173/150PMH277/LG/A-33/HSAS14-534188A / HA01S-TM1/ LG

1 2 3 4 5-10 11 12-14

See pages 22 - 27
Omit for 1W Wall Mount.

1 Mounting:

Plan View:

					Wall Mount
Cat. No.:	1A	2B	3Y	4C	1W
EPA 17":	0.8	1.6	2.4	2.8	n/a
EPA 25":	1.5	3.0	4.5	5.2	n/a

NOTE: 1A, 2B, 3Y, and 4C mounting arms are part of the Pole Assembly (pages 22 - 27) or Slipfitter Mount (page 19). 1W Wall Mount arm **not** included and must be ordered separately. See page 20 for styles and ordering information.

2 Fixture:

Cat. No. designates RA fixture and light distribution.

See the Kim Site/Roadway Optical Systems Catalog for detailed information on reflector design and application.

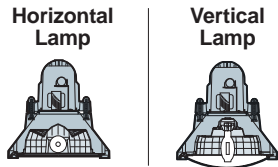

Horizontal Lamp					
Flat Lens					
Full Cutoff					
Light Distribution:	Type I	Type II	Type III	Type IV Forward Throw	Type V Square
Cat. No.:	17" 25"	RA171 RA251	RA172 RA252	RA173 RA253	RA174 RA254
Vertical Lamp					
Convex Lens					
Cutoff			Asymmetric		Symmetric Square
Light Distribution:					
Cat. No.:	17" 25"		RA17F3 RA25F3		RA17F5 RA25F5

3 Electrical Module:

PMH = Pulse Start Metal Halide
MH = Metal Halide
HPS = High Pressure Sodium

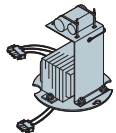

Lamp Watts	Lamp Type	Line Volts
400	HPS	277

RA17 17" Housing		RA25 25" Housing	
Pulse Start Metal Halide	High Pressure Sodium	Pulse Start Metal Halide	High Pressure Sodium
100PMH120	175PMH120 ¹	70HPS120	150HPS120
100PMH208	175PMH208 ¹	70HPS208	150HPS208
100PMH240	175PMH240 ¹	70HPS240	150HPS240
100PMH277	175PMH277 ¹	70HPS277	150HPS277
100PMH347	175PMH347 ¹	70HPS347	150HPS347
100PMH480	175PMH480 ¹	70HPS480	150HPS480
150PMH120		100HPS120	
150PMH208		100HPS208	
150PMH240		100HPS240	
150PMH277		100HPS277	
150PMH347		100HPS347	
150PMH480		100HPS480	
175PMH120 ¹		400PMH120	
175PMH208 ¹		400PMH208	
175PMH240 ¹		400PMH240	
175PMH277 ¹		400PMH277	
175PMH347 ¹		400PMH347	
175PMH480 ¹		400PMH480	
		150HPS120	400HPS120
		150HPS208	400HPS208
		150HPS240	400HPS240
		150HPS277	400HPS277
		150HPS347	400HPS347
		150HPS480	400HPS480
		250HPS120	
		250HPS208	
		250HPS240	
		250HPS277	
		250HPS347	
		250HPS480	

¹ 175PMH lamp not for use in horizontal lamp reflectors.

NOTE: Due to the Energy Independence and Security Act (EISA) of 2007, Kim Lighting can no longer supply probe start metal halide ballasts with its luminaires, effective January 1, 2009. Contact Kim Lighting for availability of replacement ballasts for warranty service claims.

(Visit www.aboutlightingcontrols.org or the Library of Congress website for more details).

4 Finish:

Super TGIC powder coat paint over titanated zirconium conversion coating.

Color:	Black	Dark Bronze	Light Gray	Stealth™ Gray	Platinum Silver	White	Custom Colors
Cat. No.:	BL	DB	LG	SG	PS	WH	CC
							Consult representative for custom colors.

5 Optional Glow Ring:

Cat. No.:	GR	Diffuse tempered glass securely held between the Ballast Housing and the Reflector Housing with stainless steel fasteners and silicone gaskets.	Glow Ring
-----------	-----------	---	-----------

6 Optional Photocell:

One per fixture required.

Line Volts:	120V	208V	240V	277V	480V	347V
Cat. No.:	A-30	A-31	A-32	A-33	A-34	A-35

7 Optional Convex Glass Lens:

For Horizontal Lamp Optical Systems.

Cat. No.:	CGL	Tempered convex glass lens replaces standard flat lens. For horizontal lamp Type II, Type III, Type IV, and Type V distributions. Changes light distribution from Full Cutoff to Cutoff.	Convex Lens
		NOTE: Convex lens is standard on all Vertical Lamp Optical Systems.	

8 Optional Polycarbonate Lens:

Cat. No.: **LS** Polycarbonate Lens replaces standard tempered glass lens. 250 watt maximum. May be used with 400HPS in outdoor locations where ambient air temperature during fixture operation will not exceed 85°F. Changes light distribution on horizontal lamp models from Full Cutoff to Cutoff. See **"CAUTION"** on page 19.

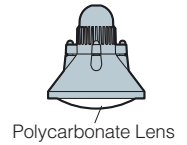

9 Optional Houseside Shield:

Cat. No.: **HS** Recommended for use with clear lamps only. Effectiveness is reduced for coated lamps. Not for use with Type V (horizontal lamp) or symmetric (vertical lamp) light distributions.

Cat. No.: **HSC** For use with all fixtures with convex glass lens. Not for use with Type V or symmetric light distributions.

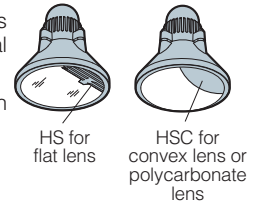

10 Optional Fusing:

Line Volts:	120V	208V	240V	277V	347V	480V
Cat. No.:	SF	DF	DF	SF	SF	DF

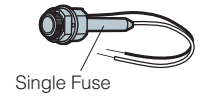

11 Poles:

See pages 22 - 27 for complete ordering and specification information.

12 Optional Slipfitter Arm Mounting for Poles by others:

See page 19 for complete details and configurations available.

NOTE: Arm assemblies for Kim poles are shown in Poles section.

RA17	Post Top Crook Arm	Side Mount Crook Arm	Post Top Swept Cast Arm
Configuration:	1SA HA01S-TM	1SA HA02S-TM1	1SA HA03S-TM1
and Cat. No.:	2SB HA02S-TM2	2SB HA03S-TM2	
Requires 2" (2 3/8" O.D.) Steel Tenon	3SY HA02S-TM3	3SY HA03S-TM3	
	4SC HA02S-TM4	4SC HA03S-TM4	
RA25	Post Top Crook Arm	Side Mount Crook Arm	Post Top Swept Cast Arm
Configuration:	1A HA01L-TM	1A HA02L-TM1	1A HA03L-TM1
and Cat. No.:	2B HA02L-TM2	2B HA03L-TM2	
Requires 2 1/2" (2 7/8" O.D.) Steel Tenon	3Y HA02L-TM3	3Y HA03L-TM3	
	4C HA02L-TM4	4C HA03L-TM4	

13 Optional Support Arm:

Drawings not to scale

RA17 RA25	RA17 RA25	RA17 RA25	RA17 RA25	RA17 RA25	RA17 RA25	
Cat. No.:	HA01S HA01L	HA02S HA02L	HA03S HA03L	HA11S HA11L	HA12S HA12L	HA14S HA14L
EPA for Fixture and Arm						
Mounting:	RA17 RA25	RA17 RA25	RA17 RA25	RA17 RA25	RA17 RA25	RA17 RA25
1SA/1A	1.1 1.8	1.3 1.9	1.3 1.9	1.5 2.3	1.4 2.0	1.7 2.6
2SB/2B	– –	2.6 3.8	2.6 3.8	3.0 4.8	2.8 4.0	3.4 5.2
3SY/3Y	– –	3.5 5.1	3.4 5.0	3.8 5.8	3.6 5.2	4.2 6.4
4SC/4C	– –	3.9 5.9	3.7 5.5	4.1 6.3	3.9 5.7	4.5 6.9
RA17 RA25	RA17 RA25	RA17 RA25	RA17 RA25	RA17 RA25		
Cat. No.:	HA31S HA31L	HA33S HA33L	HA35S HA35L	HA37S HA37L	HA38S HA38L	
EPA for Fixture and Arm						
Mounting:	RA17 RA25	RA17 RA25	RA17 RA25	RA17 RA25	RA17 RA25	
1SA/1A	1.7 2.6	1.8 2.8	1.6 2.6	1.8 2.8	2.0 3.0	
2SB/2B	3.3 5.2	3.6 5.6	3.4 5.2	3.6 5.6	4.0 6.0	
3SY/3Y	4.0 6.2	4.4 6.8	4.3 6.6	4.5 6.9	4.9 7.4	
4SC/4C	4.3 6.7	4.7 7.3	4.6 7.1	4.8 7.4	5.2 7.9	

NOTE: Refer to Kim Lighting's **Arms & Poles Selection Guide** for dimensions and details. See p. 20 for wall mounting feature.

14 Optional Arm Finial:

Cat. No.: **HAF2** Traditional style finial available to close off mounting hub opposite the fixture. Available only on selected Era arms. Refer to Kim **Arms and Poles Selection Guide** for a complete selection of heritage style finials.



Luminaire Specifications

Era® Models

Dimensions

RA17

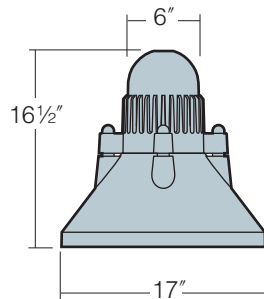

RA17
with optional
Glow Ring
and Convex Lens

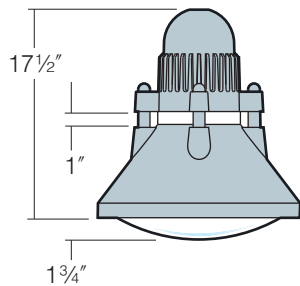

RA25

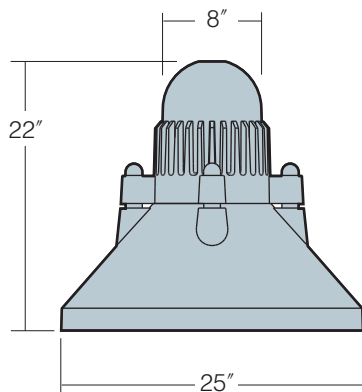

RA25
with optional
Glow Ring
and Convex Lens

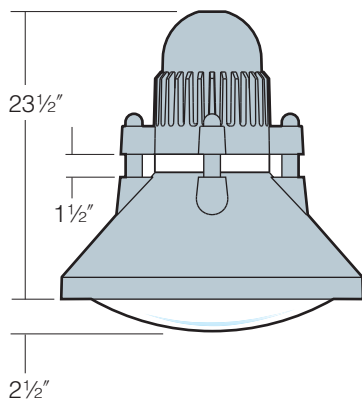

Housing: The Ballast Housing is a one piece die-cast, low copper (<0.6% Cu) aluminum¹ component with integral cooling fins. The Reflector Housing is one piece die-cast, low copper (<0.6% Cu) aluminum¹. The Ballast Housing attaches to the Reflector Housing with stainless steel fasteners and is sealed with a silicone gasket.

Lens Frame: One piece die-cast, low copper (<0.6% Cu) aluminum¹. Stainless steel hinges provided for attachment to the Reflector Housing. Stainless steel threaded fasteners provide easy access, concealed from normal view. The 3/16" thick clear flat or convex tempered glass lens seals against the reflector flange by a one piece extruded silicone gasket with fused seam, to produce a fully sealed optical chamber.

¹The aluminum material used in the die-castings is a customized 360 aluminum alloy. Additional silicone is added to the composition to allow improved molten flow characteristics that provide greater detailing and shaping.

Mounting: Stainless steel bolts are provided to attach the luminaire to the crook arm or swept arm mounting.

Reflector Module: Specular Alzak® optical segments are rigidly mounted within a die-cast, low copper (<0.6% Cu) aluminum¹ enclosure (spun for 17" vertical reflector) which attaches to the Reflector Housing as a one piece module. Reflectors are field rotatable in 90° increments. All sockets are factory prewired with a quick-disconnect plug for the ballast module, with wires passing through a silicone gasket to maintain sealed optical chamber integrity. The optical segments are positioned so that reflected light does not pass through the lamp arc tube. For the RA17, the reflector modules are equipped with medium base sockets rated 4KV. For the RA25, the horizontal metal halide lamp reflectors are equipped with a pin-oriented mogul base socket with a molded silicone lamp stabilizer. All vertical reflectors, HPS horizontal reflectors, and Pulse Start reflectors are equipped with a mogul base socket rated 4KV. All optical systems are interchangeable within the housing.

Electrical Module: All electrical components are UL and CSA recognized, mounted on a single plate and factory prewired with quick-disconnect plugs for attachment to the incoming wires and the socket wires. The module attaches inside the housing using keyhole slots. All ballasts are high power factor with starting temperatures of -40°F for HPS and -20°F for MH lamp modes. See lamp and electrical data on pages 30 - 31 for ballast types and characteristics.

Finish: Super TGIC thermoset polyester powder coat paint, 2.5 mil nominal thickness, applied over a Titanated Zirconium conversion coating; A.S.T.M. 2500 hour salt spray test endurance rating. Standard colors are Black, Dark Bronze, Light Gray, Platinum Silver, or White. Custom colors are available and subject to additional charges, minimum quantities and longer lead times. Consult representative.

Certification: UL Listed to U.S. and Canadian safety standards for wet locations. Fixture manufacturer shall employ a quality program that is certified to meet the ISO 9001:2000 standard.

CAUTION: Fixtures must be grounded in accordance with local codes or the National Electrical Code. Failure to do so may result in serious personal injury.

See pages 16-17 for complete ordering information

Wall Mounting: Cast aluminum wall mounting plate pre-attaches to wall with bolts (by others). A cast cover with crook attachments hangs on mounting plate during field wiring and fastening. Splice cover supplied. See photo on page 4. **1W** Wall Mount arm **not** included. See page 20 for ordering.

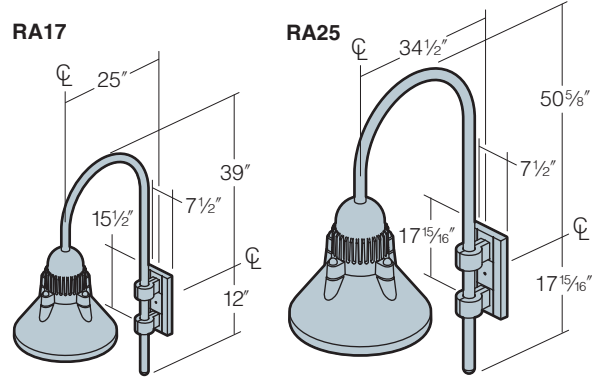

Glow Ring: Diffuse tempered glass securely held between the Ballast Housing and Reflector Housing with stainless steel fasteners and silicone gaskets. Extruded aluminum spacers extend Ballast Housing to Reflector Housing connections. See photo on page 9.

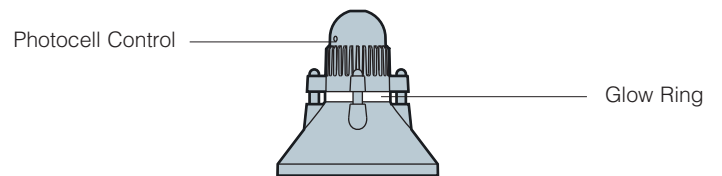

Photocell Control: Factory installed fully gasketed sensor.

Convex Glass Lens: The 3/16" thick clear convex tempered glass lens replaces the standard flat glass lens in horizontal lamp fixtures. Provides increased lens presence and provides a subtle improvement in uniformity where pole spacing is extreme.

NOTE: Convex Lens is standard on all Vertical Lamp Optical Systems.

Polycarbonate Lens: One piece vacuum formed, clear, UV stabilized convex polycarbonate, fully gasketed, replacing the standard tempered glass lens. 250 watt maximum. May be used with 400 watt HPS in locations where ambient air temperature during fixture operation will not exceed 85°F.

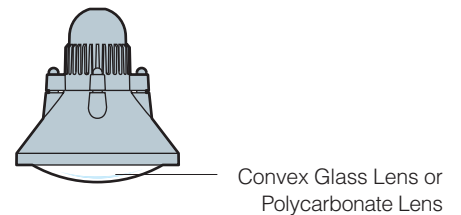

CAUTION: Use only when vandalism is anticipated to be high. Useful life is limited by UV discoloration from sunlight and metal halide lamps.

Houseside Shield: (Types II, III, IV, and Asymmetric distributions only). The cutoff horizontal reflectors are available with stamped aluminum louvers that pass streetside light and block houseside light, and a blackened panel added to the reflector to reduce houseside reflections. The vertical reflectors and horizontal reflectors with the optional convex glass lens are available with a formed aluminum shield that passes streetside light and blocks houseside light, and a blackened panel added to the reflector to reduce houseside reflections.

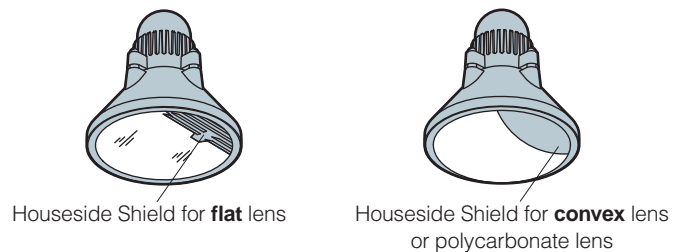

Fusing: High temperature fuse holders factory installed. Fuse is included.

Slipfitter Mounts for Poles by others:

For steel tenons only

Cast aluminum tenon adapter, bolted to extruded and formed arm. Secured by four 3/8" stainless steel set point allen screws.

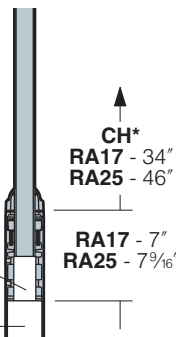

Pole Top Tenon

Pole supplied by others

HA01S fits 2" steel pipe-size tenon
HA01L fits 2 1/2" steel pipe-size tenon

Cast aluminum tenon adapter, bolted to extruded and formed arm. Secured by thru bolt and four 3/8" stainless steel set point allen screws.

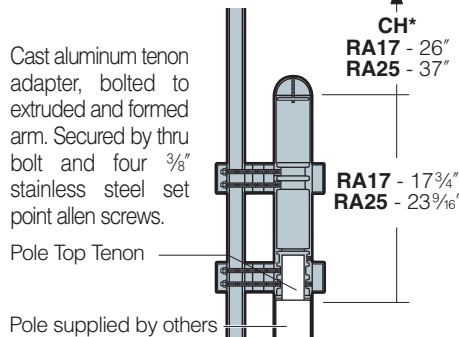

Pole Top Tenon

Pole supplied by others

HA02S fits 2" steel pipe-size tenon
HA02L fits 2 1/2" steel pipe-size tenon

Cast aluminum tenon adapter and arm. Secured by four 3/8" stainless steel set point allen screws.

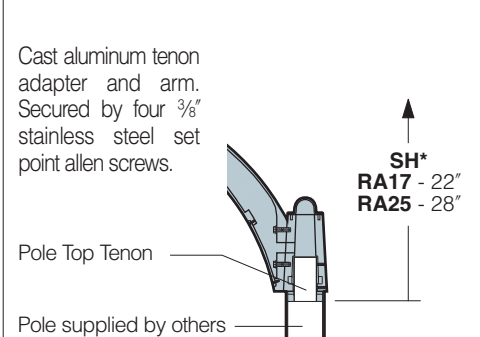

Pole Top Tenon

Pole supplied by others

HA03S fits 2" steel pipe-size tenon
HA03L fits 2 1/2" steel pipe-size tenon

*NOTE: CH and SH Detailing and Arm Spacing Dimensions match corresponding pole arm designs, see pages 22 - 26.

Wall Mounting Options

HA02LW Large Side Crook Arm Wall Mount

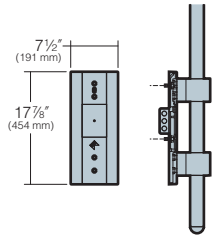

HA02SW Small Side Crook Arm Wall Mount

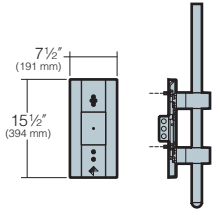

HA11LW Swept Cast Arm Wall Mount

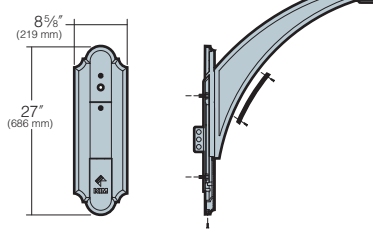

HA11SW Swept Cast Arm Wall Mount

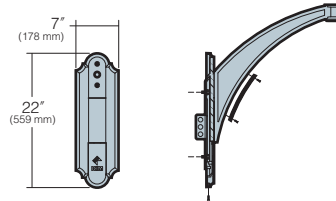

HA12LW S-Shaped Up Cast Arm Wall Mount

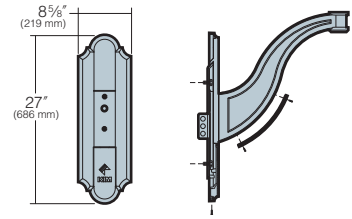

HA12SW S-Shaped Up Cast Arm Wall Mount

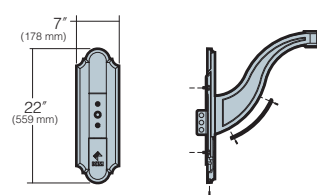

HA14LW Neo-Classic Arm Wall Mount

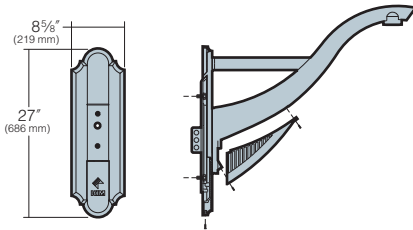

HA14SW Neo-Classic Arm Wall Mount

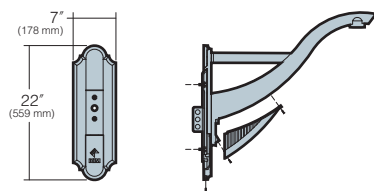

HA31LW Ribbon Arm with Top Scroll Wall Mount

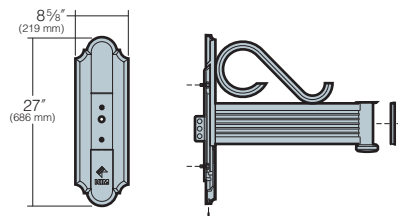

HA31SW Ribbon Arm with Top Scroll Wall Mount

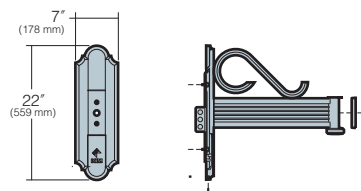

HA33LW Ribbon Arm with top Gusset Wall Mount

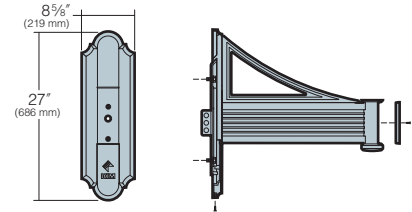

HA33SW Ribbon Arm with top Gusset Wall Mount

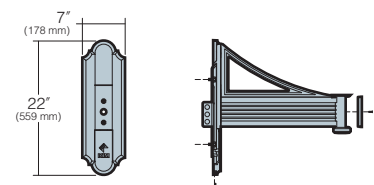

NOTE: Wall mount arm is **not** included and must be ordered separately.



Riverfront Park

WHELESTON

Riverfront Park

Riverfront Park

Riverfront Park

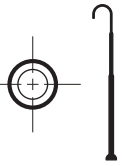

3 Pole Finish:

Super TGIC powder coat paint over Titanated Zirconium conversion coating.

Color:	Black	Dark Bronze	Light Gray	Platinum Silver	White	Custom Colors
Cat. No.:	BL	DB	LG	PS	WH	CC
						Consult representative for custom colors.

4 Optional Duplex Receptacle:

Mounted opposite the handhole in a cast aluminum box, internally welded and sealed with a gasketed self-closing cover and locking bracket.

DR Duplex Receptacle rated 15A., 125V.

DR-GFI Duplex Receptacle with Ground Fault Circuit Interrupter rated 15A., 125V.

Specifications

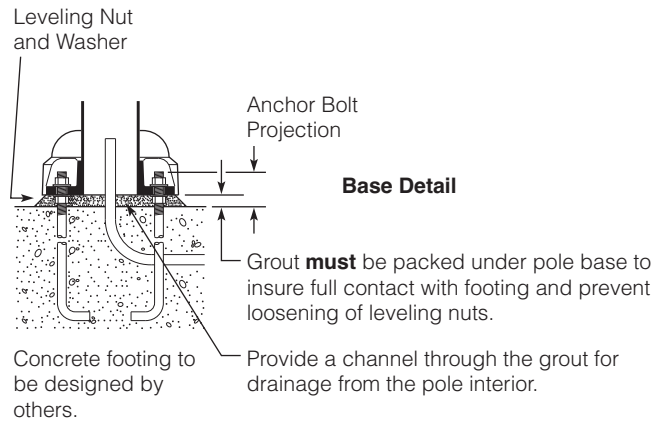
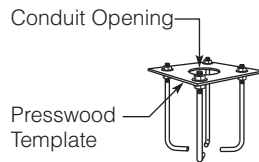
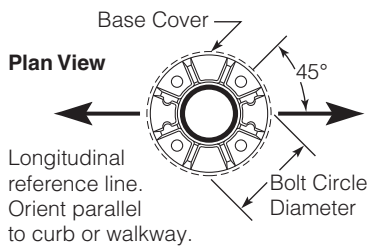

Pole Construction: Seamless round extruded aluminum tube of alloy 6063-T6, welded to top and bottom of aluminum base casting of alloy 356. Base has a two piece cast aluminum full cover of 319 alloy and is secured by stainless steel screws.

Handhole: 18" up from base, with a gasketed cover and ground lug.

Mounting Accessories: Four galvanized anchor bolts provided complete with eight nuts, eight flat washers, and a presswood template.

Strength: Poles shall withstand steady winds as listed in chart (see opposite page) when luminaires are mounted per fixture installation instructions.

CAUTION: Do not install poles without luminaires or strength guarantee is voided. Any unauthorized accessories secured to pole shall void strength guarantee.

Finish: Super TGIC thermoset polyester powder coat paint applied over a titanated zirconium conversion coating. Standard colors are Black (**BL**), Dark Bronze (**DB**), Light Gray (**LG**), Platinum Silver (**PS**), and White (**WH**). Custom colors are available and subject to additional charges, minimum quantities and longer lead times.



3 Pole Finish:

Super TGIC powder coat paint over titanated zirconium conversion coating.

Color:	Black	Dark Bronze	Light Gray	Platinum Silver	White	Custom Colors
Cat. No.:	BL	DB	LG	PS	WH	CC

Consult representative for custom colors.

4 Optional Duplex Receptacle:

Mounted opposite the handhole in a cast aluminum box, internally welded and sealed with a gasketed self-closing cover and locking bracket.

DR Duplex Receptacle rated 15A., 125V.

DR-GFI Duplex Receptacle with Ground Fault Circuit Interrupter rated 15A., 125V.

Specifications

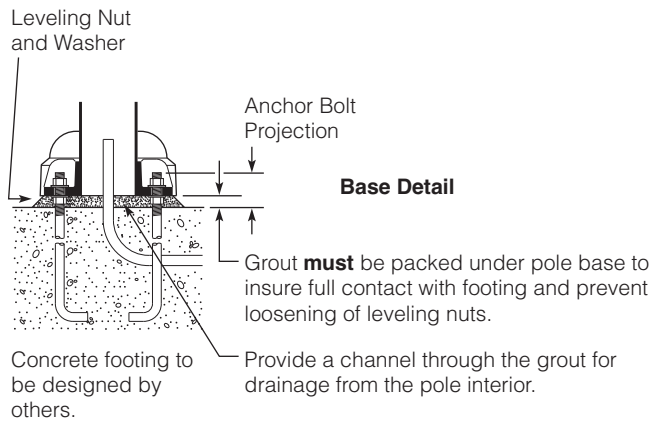
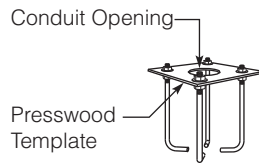
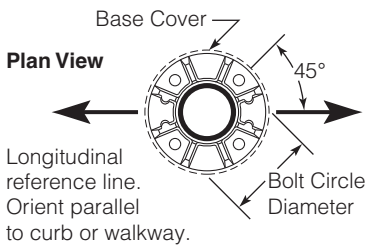

Pole Construction: Seamless round extruded aluminum tube of alloy 6063-T6, welded to top and bottom of aluminum base casting of alloy 356. Base has a two piece cast aluminum full cover of 319 alloy and is secured by stainless steel screws.

Pole Cap: A domed cast aluminum pole cap shall be provided.

Handhole: 18" up from base, with a gasketed cover and ground lug.

Mounting Accessories: Four galvanized anchor bolts provided complete with eight nuts, eight flat washers, and a presswood template.

Strength: Poles shall withstand steady winds as listed in chart (see opposite page) when luminaires are mounted per fixture installation instructions.

CAUTION: Do not install poles without luminaires or strength guarantee is voided. Any unauthorized accessories secured to pole shall void strength guarantee.

Finish: Super TGIC thermoset polyester powder coat paint applied over a Titanated Zirconium conversion coating. Standard colors are Black (**BL**), Dark Bronze (**DB**), Light Gray (**LG**), Platinum Silver (**PS**), and White (**WH**). Custom colors are available and subject to additional charges, minimum quantities and longer lead times.

3 Pole Finish:

Super TGIC powder coat paint over titanated zirconium conversion coating.

Color:	Black	Dark Bronze	Light Gray	Platinum Silver	White	Custom Colors
Cat. No.:	BL	DB	LG	PS	WH	CC
						Consult representative for custom colors.

4 Optional Duplex Receptacle:

Mounted opposite the handhole in a cast aluminum box, internally welded and sealed with a gasketed self-closing cover and locking bracket.

DR Duplex Receptacle rated 15A., 125V.

DR-GFI Duplex Receptacle with Ground Fault Circuit Interrupter rated 15A., 125V.

Specifications

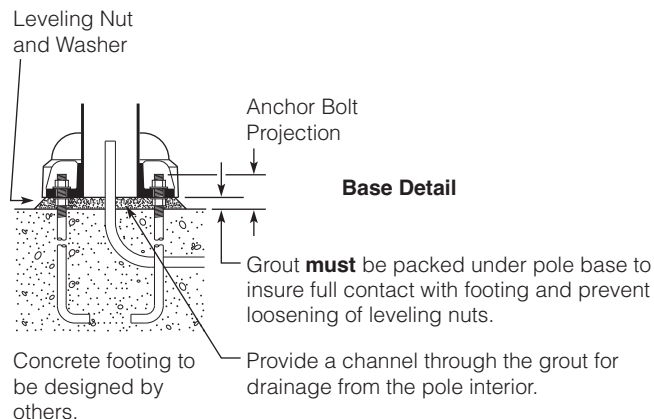
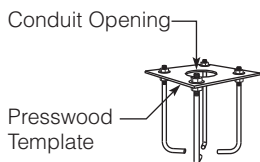
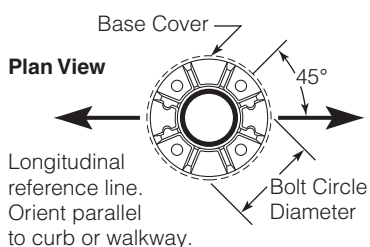

Pole Construction: Seamless round extruded aluminum tube of alloy 6063-T6, welded to top and bottom of aluminum base casting of alloy 356. Base has a two piece cast aluminum full cover of 319 alloy and is secured by stainless steel screws.

Handhole: 18" up from base, with a gasketed cover and ground lug.

Mounting Accessories: Four galvanized anchor bolts provided complete with eight nuts, eight flat washers, and a presswood template.

Strength: Poles shall withstand steady winds as listed in chart (see opposite page) when luminaires are mounted per fixture installation instructions.

CAUTION: Do not install poles without luminaires or strength guarantee is voided. Any unauthorized accessories secured to pole shall void strength guarantee.

Finish: Super TGIC thermoset polyester powder coat paint applied over a titanated zirconium conversion coating. Standard colors are Black (**BL**), Dark Bronze (**DB**), Light Gray (**LG**), Platinum Silver (**PS**), and White (**WH**). Custom colors are available and subject to additional charges, minimum quantities and longer lead times.

Wind Map

United States

EPA Information

All allowable pole and fixture EPAs (Fixture Area x Drag Factor) are derived from the AASHTO standard (American Association of State Highway and Transportation Officials). Responsibility lies with the specifier for correct pole selection based on local codes and standards for the job location.

To obtain more information on AASHTO Standards for Lighting Equipment contact:

American Association of State Highway and Transportation Officials:

444 N. Capitol Street, NW, Suite 249
Washington, DC 20001
(202) 624-5800

www.aashto.org

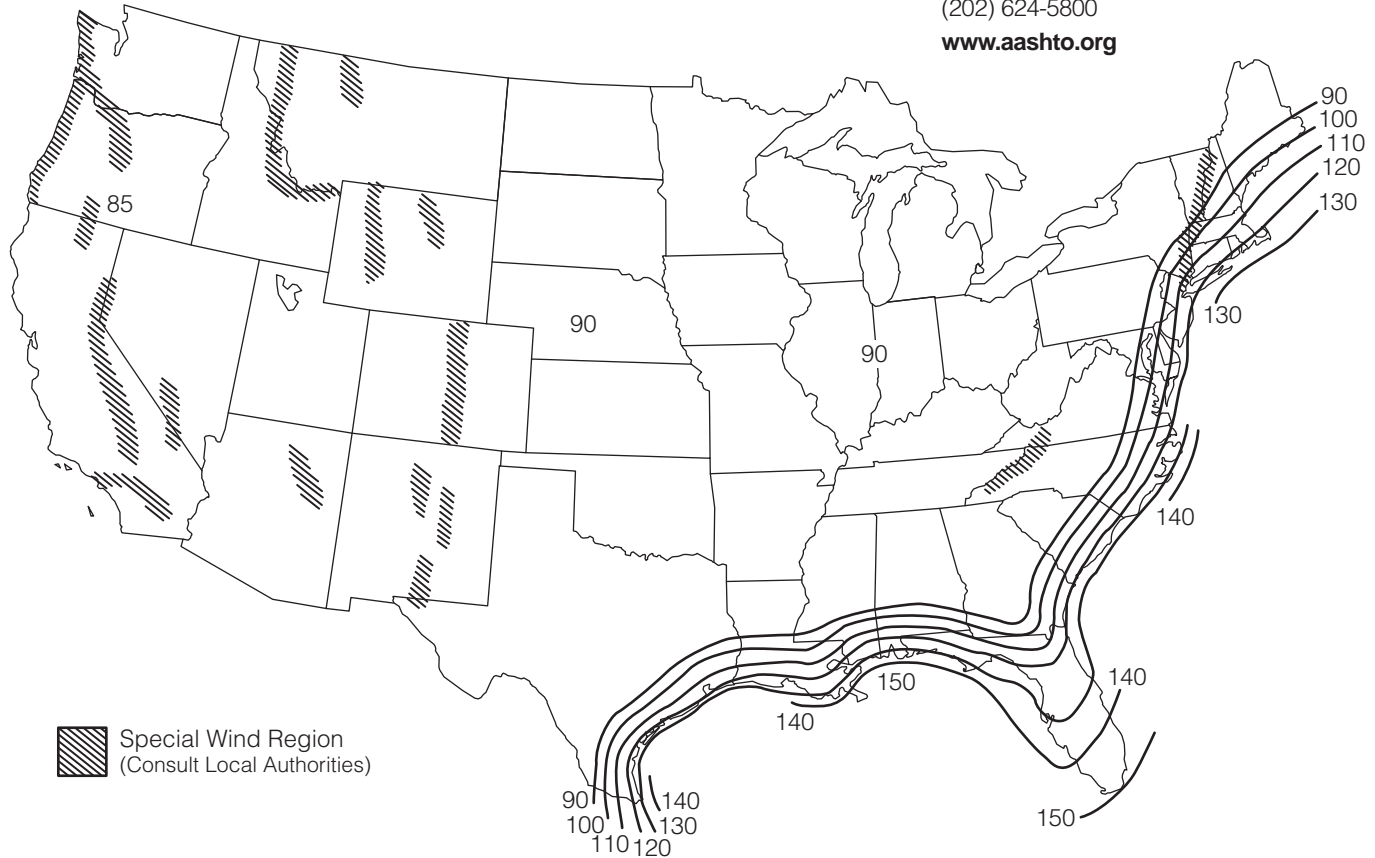

NOTES:

- Values are based on 50 year mean recurrence interval.
- Hawaii has an **105 mph** wind velocity.
- Puerto Rico has a **125 mph** wind velocity.
- Caution must be exercised in determining wind velocities in special wind areas such as:
 - Mountainous Regions
 - Areas surrounding the Great Lakes or other large bodies of water or open land.
 - Areas subject to extreme wind conditions, such as hurricanes, typhoons, cyclones, and tornadoes.
 - Areas adjacent to airports.Any specific area with a known or suspected abnormally high intermittent wind condition caused by geography, adjacent structures, or other specific local conditions that may not be recorded in National Weather Service records.
- Allowable pole EPA for jobsite wind conditions must be equal to or greater than fixture EPA. Responsibility lies with the specifier for correct pole selection based on AASHTO wind map and job location.

- The Wind Map is intended only as a general guide. Always consult local authorities to determine maximum wind velocities, gusting and unique wind conditions for each specific application.

CAUTION:

- Wind speeds and listed EPAs are for ground mounted installations. Poles mounted on structures (such as bridges and buildings) must consider coefficient of height factors beyond this general guide.
- Extreme Wind Events: Hurricanes, Typhoons, Cyclones, or Tornadoes expose poles to flying debris, wind shear, and other unpredictable aerodynamic forces not indicated by the wind velocity ratings.
- Pole Strength Limited Warranty: Standard, unmodified Kim lighting Poles installed as recommended, undamaged by corrosion, or lack of maintenance, shall withstand steady wind conditions as provided on each poles Allowable Pole EPA chart. Installation of poles without luminaires, or attachment of any unauthorized accessories to poles shall void this warranty.

Ref: AASHTO 2001

Proportion Guide

70 to 400 Watt / 10' to 30' Poles

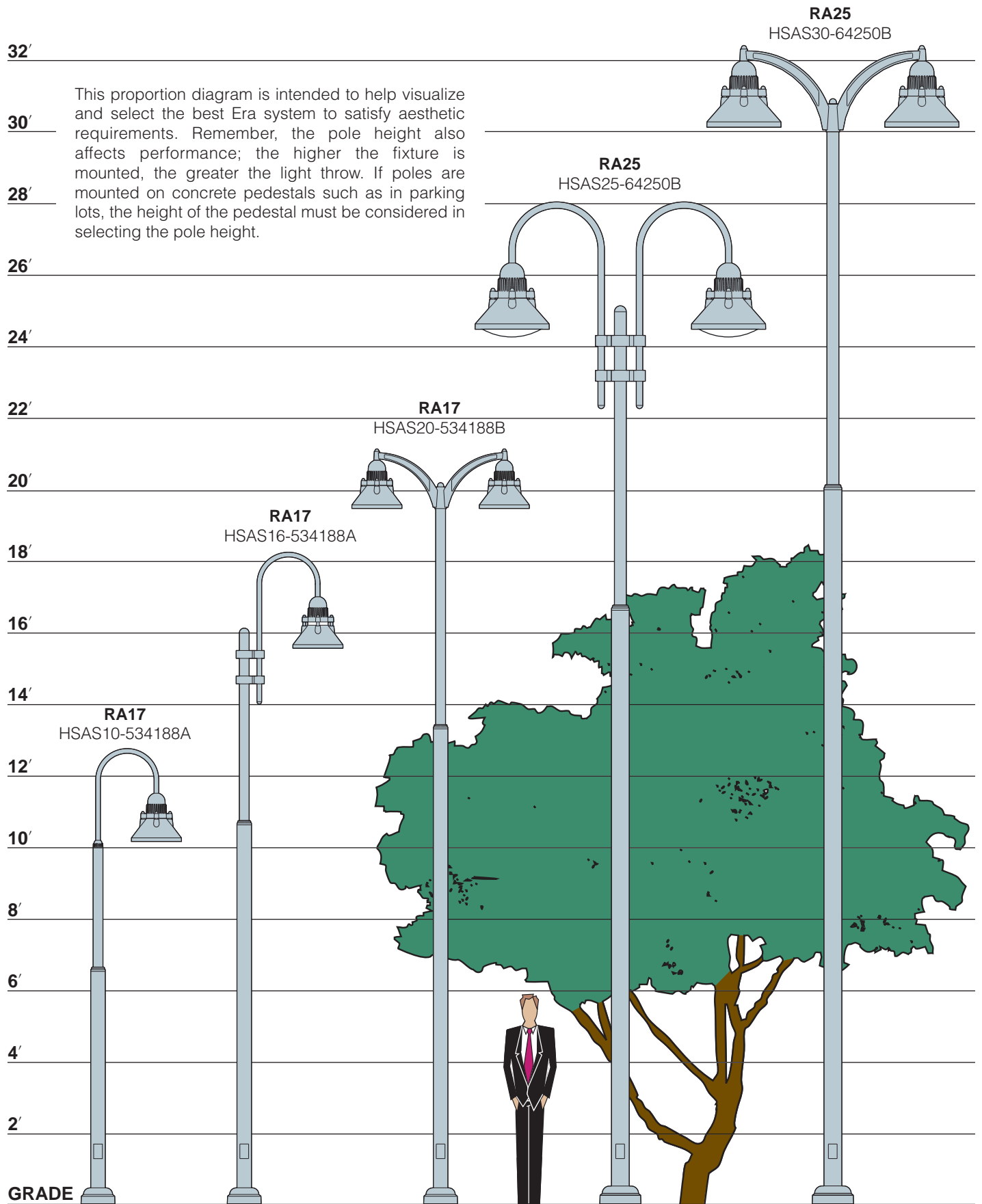

Lamp and Electrical Guide

Lamp	Lamp Watts	ANSI Ballast Type	Life (Hours)	Initial Lumens ¹	Voltage	Operating Amps.	Open Circuit	Starting Amps.	Max. Amps.
HIGH PRESSURE SODIUM									
70HPS									
ED-17 Clear Medium Base (RA17 only)	70	S-62	24000	6300	120	0.81	1.45	0.75	1.45
					208	0.47	0.85	0.45	0.85
					240	0.40	0.75	0.37	0.75
					277	0.35	0.65	0.35	0.65
					347	0.30	0.55	0.30	0.55
480*	0.21	0.36	0.21	0.36					
100HPS									
ED-17 Clear Medium Base (RA17 only)	100	S-54	24000	9500	120	1.15	2.20	1.30	2.20
					208	0.67	1.25	0.75	1.25
					240	0.58	1.10	0.65	1.10
					277	0.50	0.85	0.60	0.85
					347	0.39	0.70	0.45	0.70
480*	0.29	0.55	0.35	0.55					
150HPS									
E-23½ Clear Mogul Base (RA25 only) ED-17 Clear Medium Base (RA17 only)	150	S-55	24000	16000	120	1.65	2.80	2.00	2.80
					208	0.95	1.60	1.15	1.60
					240	0.83	1.40	1.00	1.40
					277	0.72	1.25	0.85	1.25
					347	0.56	0.92	0.52	0.92
480*	0.42	0.70	0.50	0.70					
250HPS									
E-18 Clear Mogul Base (RA25 only)	250	S-50	24000	29000	120	2.50	1.70	1.65	2.50
					208	1.50	1.00	0.95	1.50
					240	1.30	0.85	0.80	1.30
					277	1.10	0.75	0.70	1.10
					347	0.93	0.70	0.60	0.93
480	0.63	0.45	0.40	0.63					
400HPS									
E-18 Clear Mogul Base (RA25 only)	400	S-51	24000	51000	120	3.80	2.00	3.30	3.80
					208	2.20	1.20	1.80	2.20
					240	1.90	0.95	1.50	1.90
					277	1.70	0.85	1.40	1.70
					347	1.32	0.70	1.00	1.32
480	0.97	0.55	0.75	0.97					
PULSE START METAL HALIDE									
100PMH⁵									
ED-17 Clear Medium Base (RA17 only)	100	M-90	10000	7800	120	1.15	2.60	1.15	2.60
					208	0.66	1.50	0.66	1.50
					240	0.58	1.30	0.58	1.30
					277	0.50	1.15	0.50	1.15
					347	0.40	1.00	0.40	1.00
480*	0.31	0.62	0.25	0.62					
150MH⁵									
ED-17 Clear Medium Base (RA17 only)	150	M-102	15000	14400	120	1.60	3.65	0.95	3.65
					208	0.90	2.10	0.55	2.10
					240	0.80	1.80	0.50	1.80
					277	0.70	1.58	0.42	1.58
					347	0.55	1.25	0.65	1.25
480*	0.45	1.00	0.30	1.00					

⁵ **CAUTION:** All manufacturers of metal halide lamps recommend turning them off for 15 minutes once per week when under continuous operation. This will reduce the risk of arc tube rupture at end of life. Also, color temperature may differ between manufacturers of metal halide lamps. See lamp manufacturers' specification sheets.

Lamp	Lamp Watts	ANSI Ballast Type	Life (Hours)	Initial Lumens ¹	Voltage	Operating Amps.	Open Circuit	Starting Amps.	Max. Amps.
PULSE START METAL HALIDE³									
175PMH²									
ED-28 Clear Mogul Base (RA25 only)	175	M-137	15000	17500	120	1.80	1.80	0.95	1.80
					208	1.05	1.05	0.55	1.05
					240	0.90	0.90	0.45	0.90
					277	0.80	0.80	0.40	0.80
					347	0.65	0.65	0.30	0.65
ED-17 Clear Medium Base (RA17 only)					480	0.45	0.44	0.26	0.45
					120	2.50	1.40	1.90	2.50
					208	1.45	0.80	1.10	1.45
					240	1.25	0.70	0.96	1.25
					277	1.10	0.65	0.85	1.10
250PMH	250	M-138	15000	26300	347	0.90	0.50	0.62	0.90
					480	0.57	0.48	0.21	0.57
					120	4.00	3.00	3.50	4.00
					208	2.30	1.15	2.00	2.30
					240	2.00	1.00	1.75	2.00
400PMH	400	M-135	20000	44000	277	1.75	0.85	1.50	1.75
					347	1.40	0.70	1.20	1.40
					480	1.00	0.55	0.90	1.00

¹ All initial lumen values shown may vary, due to operating orientation (vertical / horizontal), and from one manufacturer to another. Consult lamp manufacturer's data for exact lumen and life data.

² 175W pulse rated lamps are for use in vertical lamp luminaires only.

³ Data provided is extracted from Venture Uni-Form product information.

⁴ 480 volt with medium base lamp sockets may require approval by the local building code authority.

NOTE: For lamp/ballast information outside of the U.S.A. and Canada, please consult your local Kim representative.

WARNING: All fixtures must be grounded in accordance with local codes or the National Electrical Code. Failure to do so may result in serious personal injury.

Lamps by others.

Application Engineering Services



Applications Assistance

Kim Lighting utilizes the latest computer technology and software to provide specifiers with reliable evaluations of lighting system performance. We can analyze a proposed luminaire layout or provide recommendations based on performance criteria.

Electronic copies of plans can be sent directly to yyeager@hubbell-ltg.com. Hard copies can be sent by fax at 864-678-1743, or they can be mailed to Applications Dept, 701 Millennium Blvd, Greenville, SC 29607.

Photometric Files

Kim Lighting .ies format photometric files are available for use in lighting calculation software. The complete IES File Library is on the internet at www.kimlighting.com.

Era[®]

Heritage Style Luminaire



Because of a continuing product improvement program, Kim Lighting reserves the right to change specifications without notice.

How may we serve you better?
Let us know by visiting our web site at:
www.kimlighting.com

Your input is valuable to us.



KIM LIGHTING

