

# **SITE / ROADWAY** **Optical Systems**

**DESIGN AND APPLICATION GUIDE**

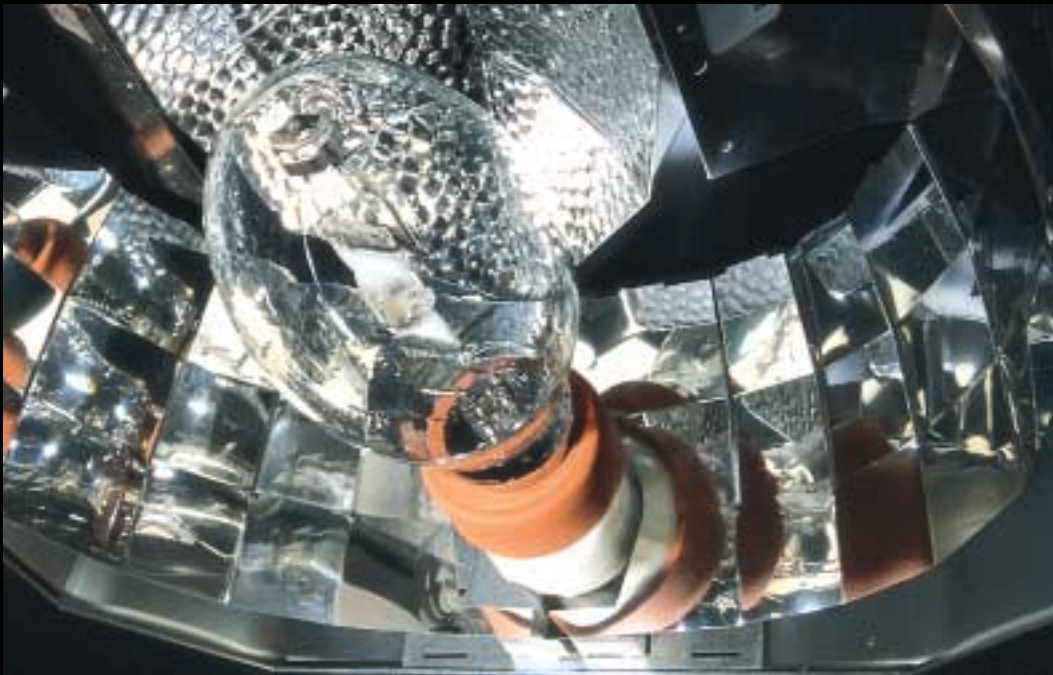

# Site / Roadway

## Optical Systems

### Table of Contents

Site Integration	2-3
Photometry Information	4-7
Distribution Types	8-10
Cutoff Description	11
Isofootcandle Plots	12-13
Application of Patterns	14
Modifiers	15
Optical Systems Design	16-17
Reflector Mechanical Design	18
Kim Systems Overview	19-20
Horizontal Lamp Luminaires	22
Vertical Lamp Luminaires	23
Horizontal Lamp	25-30
Two-Tier Vertical Lamp	31-36
Single-Tier Vertical Lamp	37-40
Applications Assistance	41
Footnotes	41



**SITE / AREA  
PARKING STRUCTURE  
ROADWAY  
ARCHITECTURAL FLOOD  
ACCENT  
LANDSCAPE**

MAILING ADDRESS:  
P.O. BOX 60080  
CITY OF INDUSTRY, CA  
91716-0080

BUSINESS ADDRESS:  
16555 EAST GALE AVENUE  
CITY OF INDUSTRY, CA 91745  
U.S.A.  
PHONE 626 / 968 - 5666  
FAX 626 / 369 - 2695

ENTIRE CONTENTS  
© COPYRIGHT 1999 KIM LIGHTING, INC.  
ALL RIGHTS RESERVED  
REPRODUCTION IN WHOLE OR IN PART  
WITHOUT PERMISSION IS STRICTLY PROHIBITED.

[www.kimlighting.com](http://www.kimlighting.com)



RVA Council  
for Accreditation

Audited to ISO9001 Standards

Printed in U.S.A.  
5502599253  
Version 1.01 (6/06)

### Introduction

The design of Site/Roadway Lighting requires an understanding of the unique information used to represent elements of optical performance. This catalog includes descriptions of the standards used to define product characteristics and predict the applied performance of outdoor area luminaires.

Kim's unique approach to optical systems design and reflector fabrication follows these fundamental definitions. The descriptions offer insight into the features and benefits of Kim's innovative optical systems.

The heart of this catalog is the Optical Systems Specifications. Used in Kim Site/Roadway products, these reflector systems are the direct result of 70 years dedicated to providing superior performance in outdoor lighting.

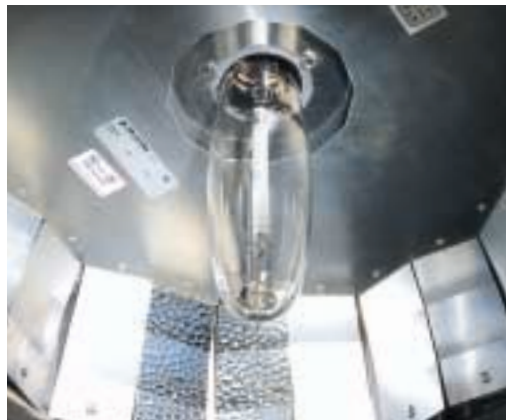
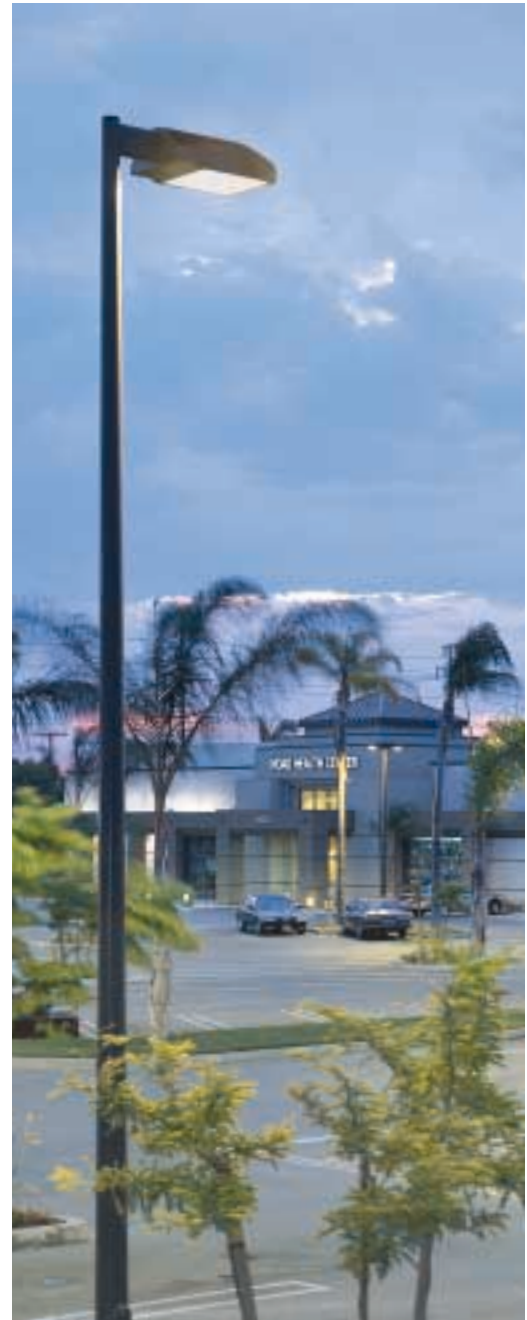

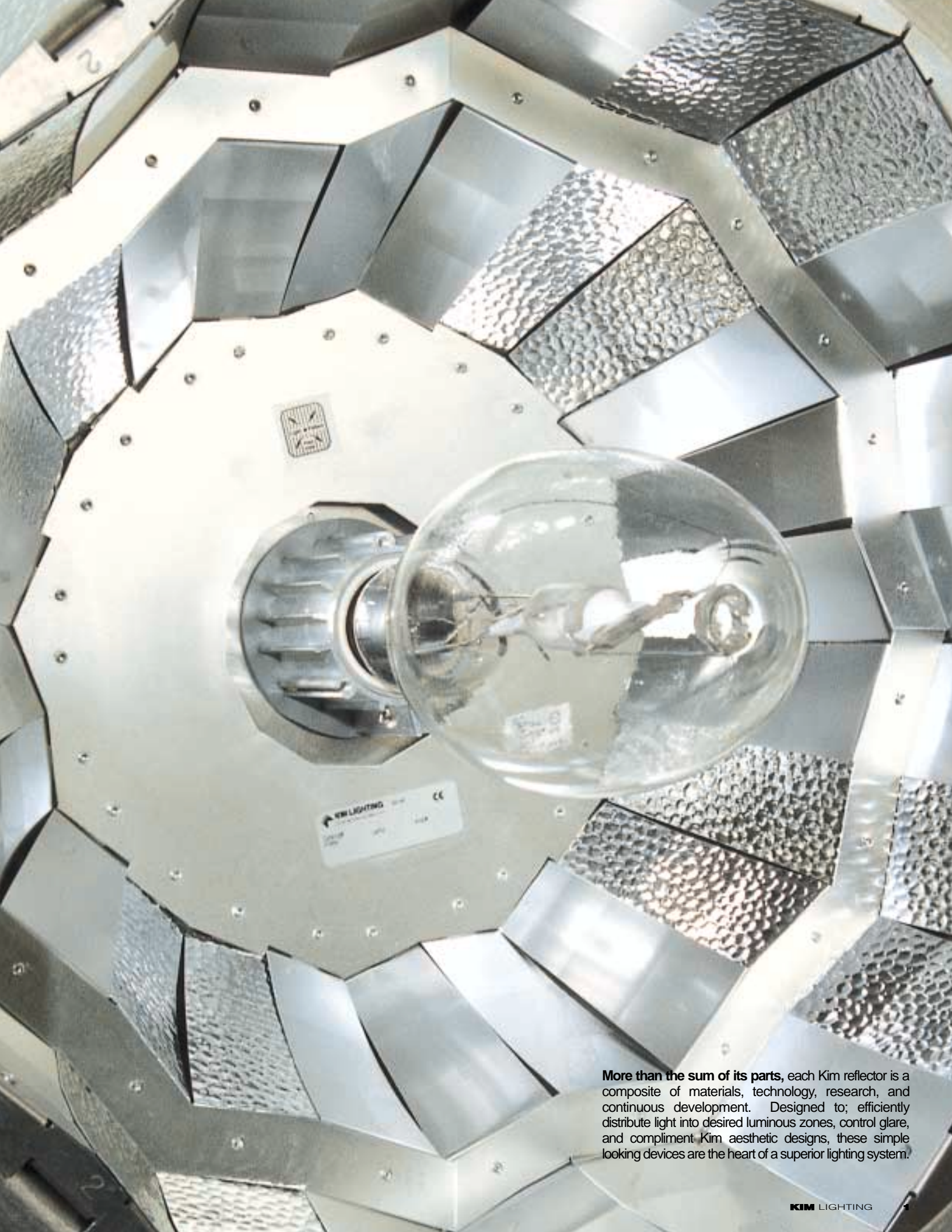

**More than the sum of its parts**, each Kim reflector is a composite of materials, technology, research, and continuous development. Designed to; efficiently distribute light into desired luminous zones, control glare, and compliment Kim aesthetic designs, these simple looking devices are the heart of a superior lighting system.

# Site Integration

## Design, Focused on Applied Performance

Conceptually, project sites can be classified into four basic areas; Roadways, Open Areas, Pedestrian Areas, and the Site Perimeter, each representing a unique set of lighting circumstances. Meeting the diverse needs of site illumination requires a wide range of solutions. Optical systems selection begins with identifying the specific illuminance requirements, combining a product's aesthetic design with relevant performance features, to achieve an integrated site lighting design.

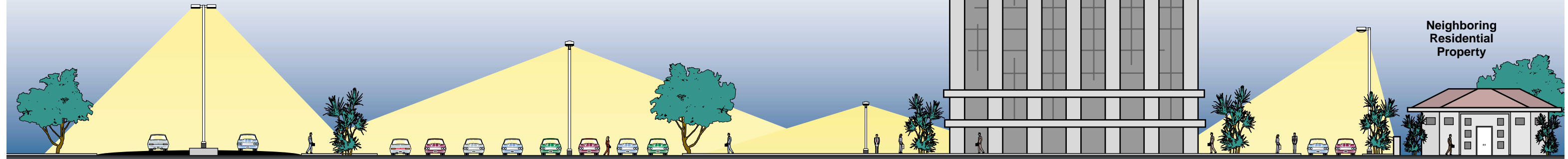

### Roadways

Roadways require narrow perpendicular and wide lateral beam spreads. This facilitates wide pole spacings, excellent uniformity, and control of glare.

Luminaire selection criteria includes performance, consideration of maintenance, lamp choices influenced by utility interests, and the ability to remain in service for long periods with minimal attention.

Optical designs must include an array of distributions in order to illuminate varied roadway widths, traffic patterns and to support traffic flow / organization.

### Open Areas

Open Areas require careful consideration of illuminance requirements, uniformity, and brightness control.

These areas are subject to scrutiny relevant to the safety and security of site occupants and the interface between vehicle and pedestrian traffic. Parking areas and connecting walkways are a potential source of litigation and liability for the project owner, requiring accurate prediction of illumination levels and dependable performance.

Illumination levels, uniformity, and glare must also be controlled to optimize visibility. Maximized luminaire spacings produce an economical installation.

### Pedestrian Areas

The transition between the surrounding site and the building itself defines the Pedestrian Area. Plazas, Courtyards, and Pathways require the widest range of optical solutions. These areas combine the concerns of Open Areas, with a heightened concern for integration of luminaire appearance with site architecture.

Illumination of irregularly shaped spaces, and a need to control stray light, requires optical diversity. Fixture placement may also be influenced by aesthetic concerns.

Luminaires in this area are highly visible, requiring attention to finish quality and detail. Design components shared with other area luminaires enhance integration of the entire site.

### Site Perimeter

The Site Perimeter may include requirements to control illumination onto adjacent properties.

Light trespass ordinances, and courtesy to neighboring property occupants, requires tight control of light emitted behind the luminaire.

Efficient design satisfies some of this demand, while cutoff optics provide an additional level of control. Houseside shields may also be required to provide even tighter control by trimming the distribution pattern. These concerns must be satisfied, without effecting overall system performance.

#### Desirable Optical Features

Lamp Orientation	Distribution Options	Cutoff Control
<b>Horizontal Lamp</b> Flat Lens	Type II	
<b>Vertical Lamp</b> Convex Lens	Type III Asymmetric	

#### Desirable Optical Features

Lamp Orientation	Distribution Options	Rotatable Optics
<b>Horizontal Lamp</b> Flat Lens	Type II	
<b>Vertical Lamp</b> Convex Lens	Type III Asymmetric	
		Cutoff Control
	Type V Symmetric	

#### Desirable Optical Features

Lamp Orientation	Distribution Options	Houseside Shield	Rotatable Optics
<b>Horizontal Lamp</b> Flat Lens	Type II	Type II	
<b>Vertical Lamp</b> Convex Lens	Type III Asymmetric	Type III Asymmetric	
			Cutoff Control
	Type IV	Type IV	
	Type V Symmetric		

#### Desirable Optical Features

Lamp Orientation	Distribution Options	Houseside Shield	Rotatable Optics
<b>Horizontal Lamp</b> Flat Lens	Type II	Type II	
<b>Vertical Lamp</b> Convex Lens	Type III Asymmetric	Type III Asymmetric	
			Cutoff Control
	Type IV	Type IV	

## Basic Language and Presentation

### Luminaire Orientation

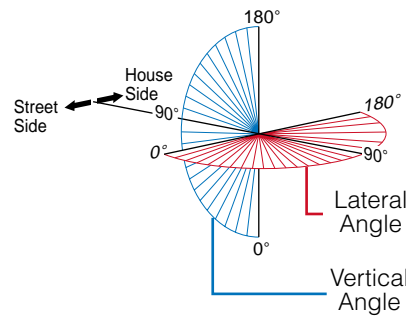

### Candela Tabulation

Presenting the raw data used for all illuminance calculations, the information is tabulated with the Vertical Angles in rows and Lateral Angles in columns.

Lateral values from 0° to 90° are in front of the luminaire and referenced as "Street Side." Lateral values from 90° to 180° are behind the luminaire and referenced as "House Side."

Vertical values from 0° to 90° are below the fixture, while values 90° to 180° are at the fixture level and above.

Candela data is also used to define a luminaire's distribution type and cutoff characteristics. See pages 8 - 11 for additional detail.

**ifl boulder**  
THE LIGHT CENTER OF THE INDUSTRY  
INDEPENDENT TESTING LABORATORIES, INC. • 3386 LONGHORN ROAD, BOULDER, CO 80302 USA • PHONE (303) 442-1255 FAX (303) 449-5274

REPORT NUMBER: ITL4-999  
DATE: 02/02/99  
PREPARED FOR: KIM LIGHTING INC.

VERTICAL ANGLE	LATERAL ANGLE										
	0.0	15.0	35.0	55.0	71.0	75.0	95.0	115.0	135.0	155.0	180.0
180.0	0.	0.	0.	0.	0.	0.	0.	0.	0.	0.	0.
155.0	0.	0.	0.	0.	0.	0.	0.	0.	0.	0.	0.
125.0	0.	0.	0.	5.	0.	5.	9.	9.	0.	0.	0.
115.0	0.	0.	0.	9.	0.	9.	12.	12.	0.	0.	0.
105.0	4.	7.	9.	12.	9.	15.	15.	15.	9.	12.	12.
95.0	7.	9.	15.	15.	15.	18.	18.	18.	12.	12.	12.
85.0	18.	24.	27.	36.	36.	45.	36.	45.	55.	45.	36.
75.0	327.	491.	700.	1701.	3893.	3993.	810.	500.	300.	518.	382.
66.0	728.	746.	2492.	4011.	8595.	8232.	3183.	1783.	1674.	1437.	1037.
65.0	782.	810.	2465.	4339.	8295.	8141.	3429.	1810.	1737.	1483.	1110.
55.0	1674.	1983.	2610.	4066.	7104.	6631.	3029.	2001.	2010.	1655.	1492.
45.0	2219.	2192.	2310.	2392.	2301.	2288.	1974.	1865.	1865.	1719.	1674.
35.0	2110.	2165.	2092.	2092.	2056.	2047.	1956.	1910.	1846.	1774.	1746.
25.0	982.	964.	1137.	1674.	1946.	1956.	1874.	1792.	1728.	1674.	1674.
15.0	582.	600.	664.	655.	582.	600.	746.	1101.	1264.	1392.	1346.
5.0	491.	491.	491.	491.	455.	464.	418.	364.	327.	318.	309.
0.0	363.	363.	363.	363.	363.	363.	363.	363.	363.	363.	363.

Maximum Candela: 8595

figure 4.1

### Footcandle Calculations

The data provided in the candela tabulation is used to calculate footcandle levels within a proposed lighting design. Generally, this is accomplished by using computers to produce numeric calculations.

The evaluations are dependent upon the accuracy of the data used to make the requisite calculations.

Figure 4.2 illustrates the relationship of the calculated illumination at a single point, to the information provided in the Candela Tabulation. See page 12, figure 10.1 for the correlating location on an Isofootcandle Plot.

$$\text{Footcandles (fc)} = \left[ \frac{\text{Candela @ VA by LA}}{D^2} \right] \times \cosine VA$$

$$\bullet \text{ fc} = \left( \frac{8595}{34.42^2} \right) \times .407 = 2.95 \text{ fc}$$

Footcandles at Maximum Candela = 2.95

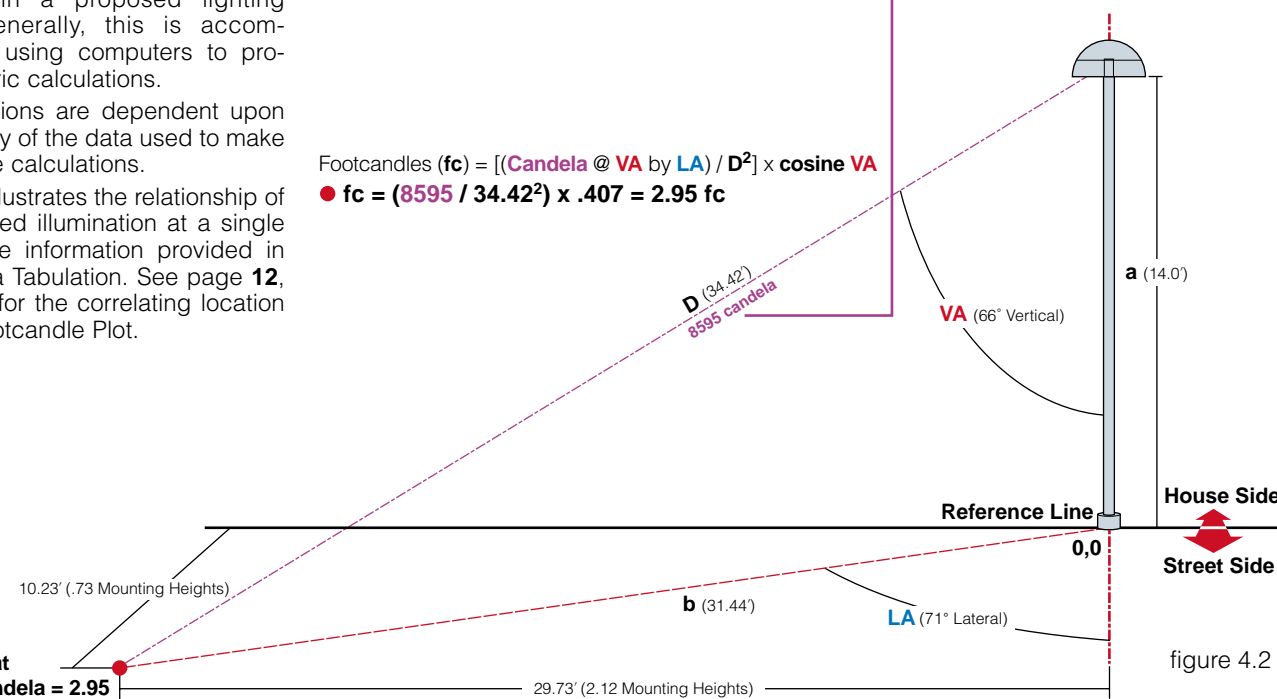

figure 4.2

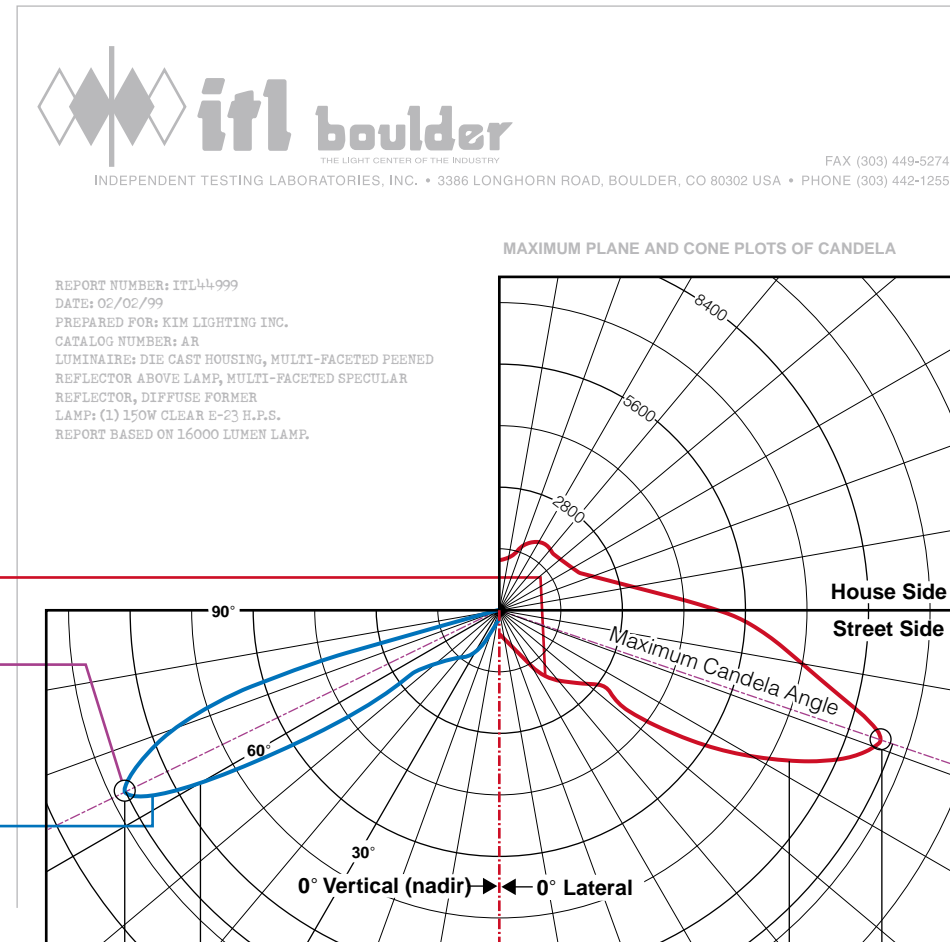

figure 5.1

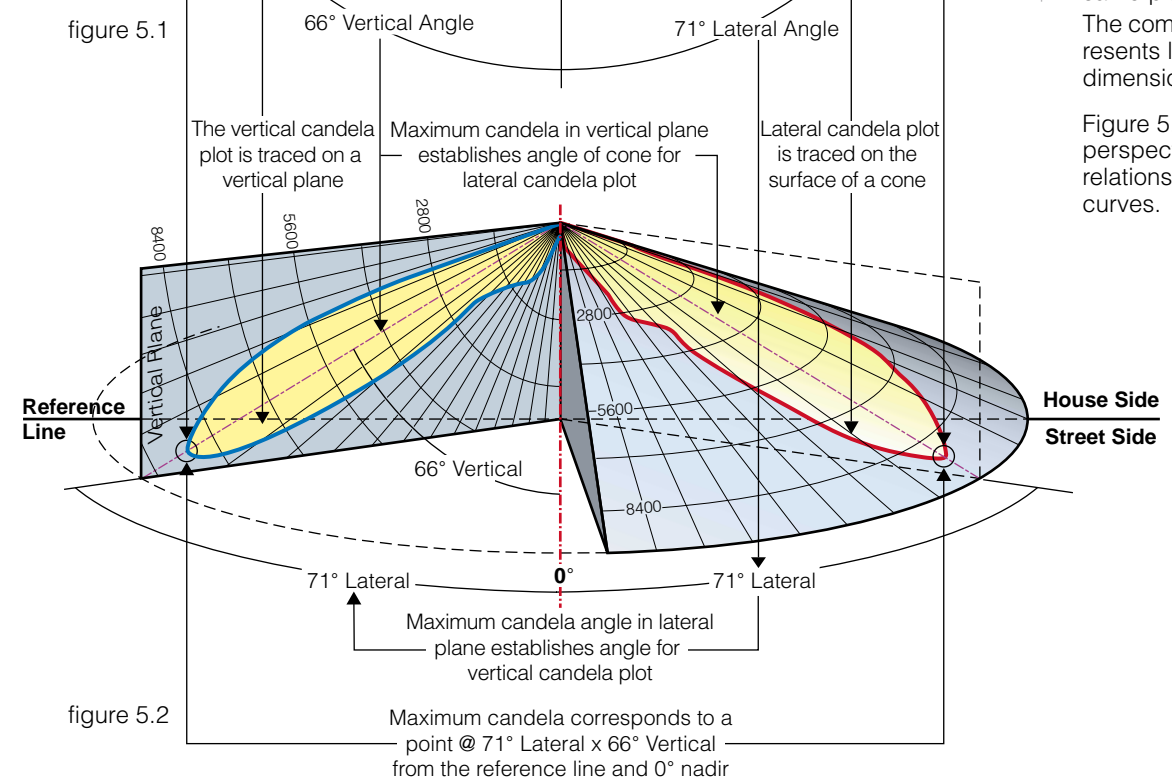

figure 5.2

### Candela Plots

Candela Plots are based on the candela tabulation data (figure 4.1). Outdoor lighting produces unique light patterns, that are difficult to represent in a flat two-dimensional plane.

To create distribution plots that illustrate luminaire performance, curves are plotted with a three-dimensional dynamic.

Using the **maximum candela value** – in this example **8595** – two planes are identified; a lateral angle of **71°**, and a vertical angle of **66°** (see figure 5.1).

The vertical angle is used to create a cone, with its slope equal to the vertical angle of **maximum candela** – in this example **66°** – on this cone, all **lateral candela distribution values** from the tabulated data **row** at **66°** are plotted. The result is shown on the right side of the chart (figure 5.1). The two-dimensional view is looking down at the top of the constructed cone.

The second value – the **lateral angle** of **71°** – is used to construct a vertical plane off the lateral baseline. On this surface, all **vertical candela distribution values** from the tabulated data **column** at **71°** are plotted. The result is shown on the left side of the chart (figure 5.1). For purposes of presenting the plot, the vertical plane is flattened – or laid back 90° – to show it in the same plane as the right side plot.

The combination of the two curves represents luminaire performance in three dimensions.

Figure 5.2 (at left) shows the chart in a perspective view, to help visualize the relationship between the two plotted curves.

## Variables Affecting Accurate Information

### The Importance of Accuracy

Site/Area Illumination design is concerned with relatively large lamp sources, applied over large areas. Visual acuity is greatly influenced by control of glare and uniformity. In this, subtle variations in the performance of luminaires have a dramatic effect on the illuminated field. The only way to accurately predict the performance of a proposed design, is through the application of accurate performance data.

### Comparing Performance

In addition to accurately predicting the performance of a single system, comparisons of performance between two systems, produced by disparate providers, can only be accomplished if the data provided by both is acquired using some form of mutually accepted standard. Ideally, this would include an independent source of testing, unbiased, utilizing industry established standards.

True comparisons of different optical systems can only be accomplished when the method of testing is the same for both systems.

### Assumptions and Compromises

To save money, many manufacturers utilize methods that compromise accuracy under the assumption that small variances are not important. Just how far these assumptions are carried is never clearly defined and varies from one provider to another. This makes it very difficult to determine where actual test information and the compromises begin and end.

To make the most qualified, informed decisions, accuracy and dependability of information is vital. Compromises and assumptions have no place in the raw data being used to make selections.

### Lamp Variations (images to scale with each other)

#### Metal Halide



#### High Pressure Sodium

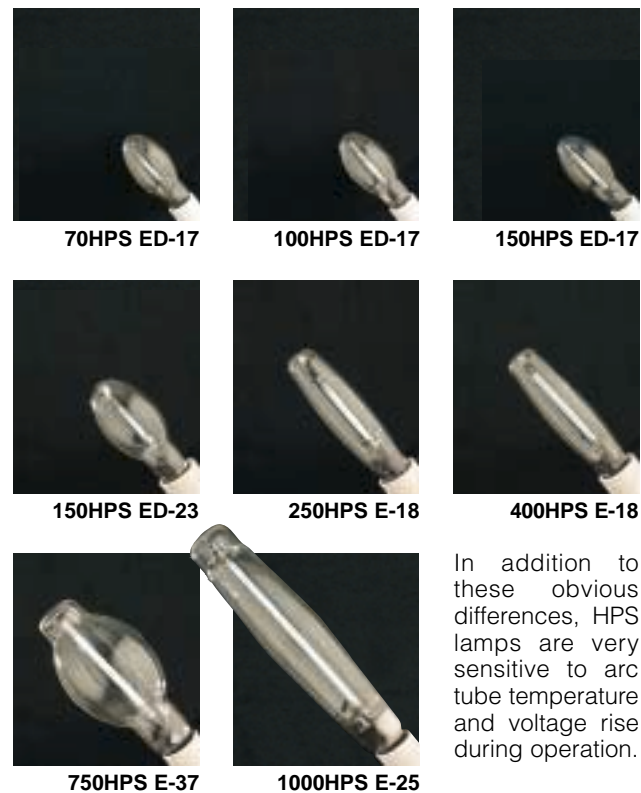

figure 6.1

### Prorating

Prorating is a common practice in the representation of luminaire performance. It is based on applying multipliers, based on raw lamp lumens, to a known test result. For example; A test accomplished on a system with a 10,000 lumen lamp, is prorated to represent a system using a 5,000 lumen lamp, by simply applying a .5 multiplier to the test data on the base luminaire.

This wrongly assumes that all other factors are exactly equal, that the only variation is raw lumens.

With High Intensity Discharge (H.I.D.) sources, every lamp is different, based on:

- Arc Tube Shape (Metal Halide or High Pressure Sodium)
- Arc Tube Size
- Envelope size (ED-17 through BT-56)
- Base Size (medium or mogul)
- Envelope shape
- Intended operating position (vertical, horizontal or universal)
- Position of the arc tube within the envelope
- Whether or not the socket design locks the lamp into a given position (pin orientation).

The combination of these elements produces unique configurations for virtually every H.I.D. lamp. Prorating cannot account for these variables.

The photos shown in figure 6.1, show the numerous variations in common H.I.D. lamps.

In addition to these variables, the position of the lamp within a reflector system, heat dissipation, internal reflection and lamp/optical system interaction are all variables not represented in prorated performance reports.

In the case of High Pressure Sodium lamps, heat plays a large part in lamp life. HPS lamp Voltage Rise at Arc Tube information is an indication of how the optical system controls arc tube heat. The higher the rise, the shorter a lamp's life will be. This is also not considered in prorated information, as it can only be gained through testing of each optical system.

**Kim does not use performance prorating to represent luminaire performance.**

### Test Sources

Photometry testing can come from several sources. The two most common are; The manufacturer or an Independent Test Facility. The two most recognized independent testing facilities are ITL of Boulder Colorado and ETL.

Manufacturers' data may or may not be trustworthy and must be carefully scrutinized. It is very difficult to determine whether the information provided by two different manufacturers can be accurately compared. Unless the testing procedures used by each producer are known, comparative results may be highly suspect. If the manufacturer has no other process in place to assure that every test is accomplished under strict procedural standards (such as ISO9001), test results may not be accurate. Without strict control, testing process may shift, creating variations from one test to another over time.

Independent testing by ITL and ETL are accomplished using IES established standards, under strict procedural processes. In addition to this, independent labs utilize seasoned lamps of known output, driven by laboratory quality ballasts, whose electrical characteristics are tightly controlled. This produces results that are accurate from one optical system to another, regardless of when they are tested.

A Hybrid method, where a core series of optical systems are tested by an independent source, with additional tests accomplished by the manufacturer, can also be used. By providing a redundant series of bench-mark tests against the independent data, the accuracy of the manufacturers' information can be determined. This allows the manufacturer to test a larger range of systems which might be otherwise impractical.

In any case, it is important to know the origin of test data. If the source is suspect, so is the information provided.

**Kim utilizes Independent Test Facilities to acquire all photometry data.**

### 400MH Type III

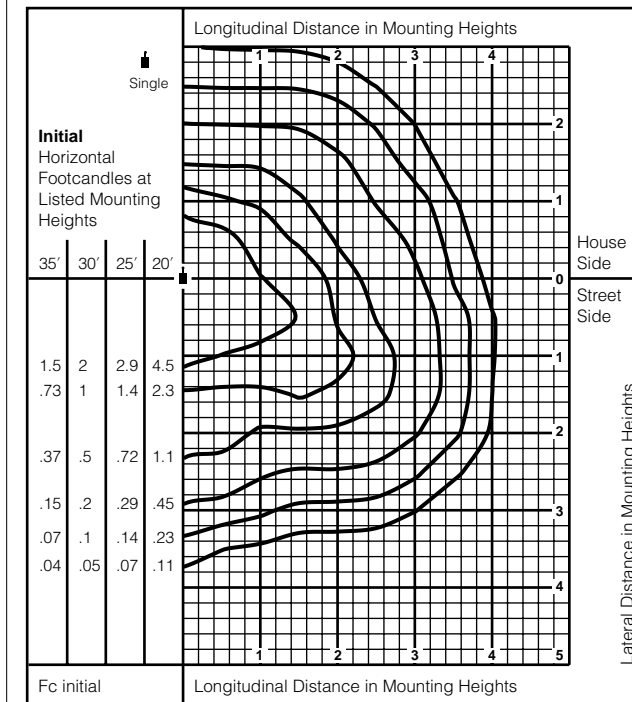

### 400HPS Type III

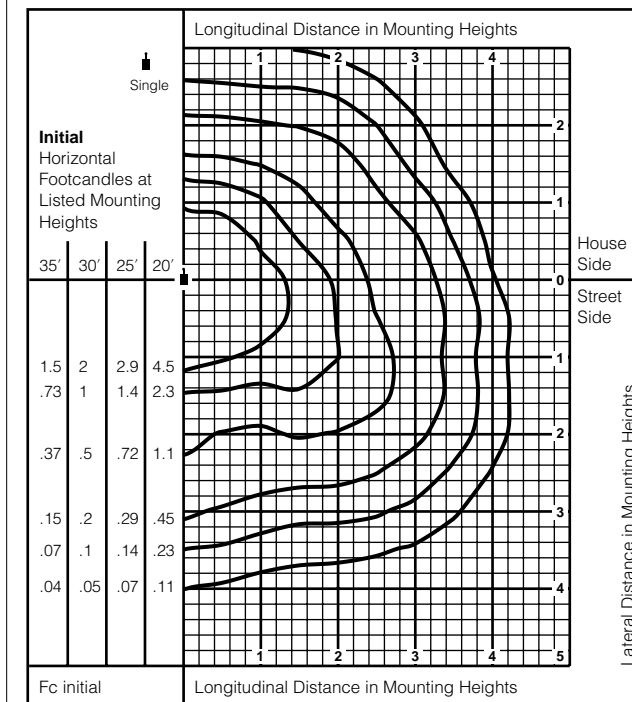

figure 7.1

### Photometric Variations

The subtle variations in these two isofootcandle footprints are based on differences in lamp configuration only. All other components of the optical systems were identical.

For more information on how to read the isofootcandle plots, see page 12.

### Optical Variations

Optical systems are precise devices, that are affected by a wide range of variables. The effects of subtle variations from one lamp to another, an arc tube design, or the position of the lamp within a reflector system, can have a dramatic impact on performance. Any change in these variables requires testing to create accurate evaluation of performance. Figure 7.1 shows an example of how two reports vary, resulting from a change of lamp (MH to HPS).

### Four Basic Rules

The following guidelines assure that the information used to evaluate and compare the performance of optical systems is the most accurate and dependable:

#### 1. Testing of every configuration

The only way to be assured that performance information is accurate is through testing. Each lamp/reflector combination must be tested. Prorating does not accurately represent actual performance.

#### 2. Known testing procedures

Testing and manufacturing should employ a quality program that is audited to **ISO9001** standards. This assures that procedures are in place that control consistency in testing and manufacture.

#### 3. Independent verification

Independent testing and/or verification is the only way to assure that the data provided is accurate and does not include special "tuning" of performance to gain more attractive test results.

#### 4. Sealed optical systems

To assure the performance desired is achieved in application and will remain so without degradation from optical system contamination, the optical chamber must be tightly sealed. See page 19 for additional details on this important feature.

# Distribution Types

## Definitions and Methodology

### Method

Outdoor Luminaires produce lighting patterns that can be identified by their reach in front and to each side of a single fixture location. Distribution Types describe the reach of the luminaire's light pattern forward of each fixture, while Distribution Ranges define the reach to either side.

### Distribution Types

Classification is based on locating the luminaire's effective major output pattern on a grid representing distances in Mounting Heights. The pattern is defined by tracing an area representing distribution at 50% of Maximum Candela. Classification is established by measuring where the bulk of this pattern falls on the grid (see figure 6.2).

In some cases, minor deviations in a beam pattern may cross the boundary from one pattern description into another. Where this has a nominal effect on applied performance, it is not considered.<sup>1</sup>

Distribution Type defines how far forward of the luminaire (Street Side) the effective output reaches. Type II defines shallow reaches, while Type IV identifies luminaires with a definite forward-throw distribution. See the following diagrams for definitions of each specific type.

### Distribution Range

Distribution Range defines how far the distribution pattern reaches laterally, perpendicular to the axis used to identify general Type. See the definitions below figure 6.2 for each of the ranges used.



REPORT NUMBER: ITL44933<sup>3</sup>  
DATE: 02/02/99  
PREPARED FOR: KIM LIGHTING INC.

	STREET SIDE						HOUSE SIDE					
	0.0	15.0	35.0	55.0	71.0	75.0	90.0	115.0	135.0	155.0	180.0	
180.0	0.	0.	0.	0.	0.	0.	0.	0.	0.	0.	0.	
155.0	0.	0.	0.	0.	0.	0.	0.	0.	0.	0.	0.	
125.0	0.	0.	0.	5.	0.	5.	9.	9.	9.	0.	0.	
115.0	0.	0.	0.	9.	0.	9.	12.	12.	12.	0.	0.	
V E R T I C A L	105.0	4.	7.	9.	12.	9.	15.	15.	15.	9.	12.	
95.0	7.	9.	15.	15.	15.	18.	18.	18.	18.	12.	12.	
85.0	18.	24.	27.	36.	36.	45.	36.	45.	55.	45.	36.	
75.0	327.	491.	700.	1701.	4325.	4325.	1256.	500.	300.	518.	382.	
66.0	728.	746.	2492.	4011.	8595.	8232.	4302.	1783.	1674.	1437.	1037.	
65.0	782.	810.	2465.	4339.	6913.	8141.	4466.	1810.	1737.	1483.	1110.	
A N G L E	55.0	1674.	1983.	2610.	4066.	4325.	2631.	3250.	2001.	2010.	1655.	
45.0	2219.	2192.	2310.	2392.	1946.	222.	1974.	1865.	1865.	1719.	1674.	
35.0	2110.	2165.	2092.	2092.	582.	2047.	1956.	1910.	1846.	1774.	1746.	
25.0	982.	964.	1137.	1674.	455.	1956.	1956.	1874.	1792.	1728.	1674.	
15.0	582.	600.	664.	655.	363.	600.	746.	1101.	1264.	1392.	1346.	
5.0	491.	491.	491.	491.	464.	418.	364.	327.	318.	309.	309.	
0.0	363.	363.	363.	363.	363.	363.	363.	363.	363.	363.	363.	

figure 6.1

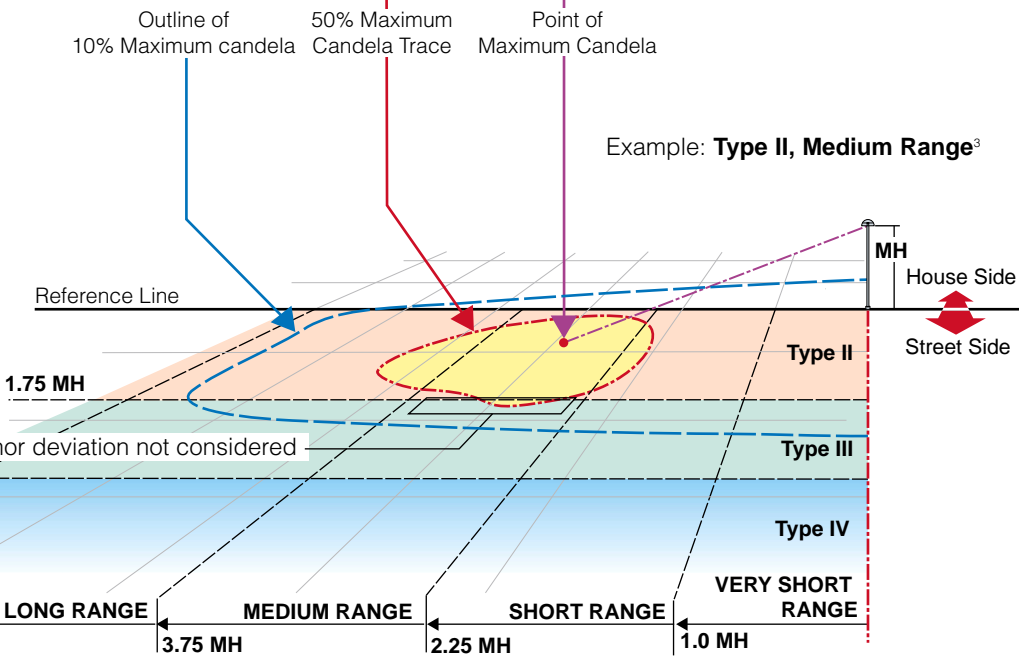

figure 6.2

### Long Range

A distribution is identified as Long Range when the point of maximum candela lies from **3.75 to 6.0 MH** from the luminaire's centerline, along the reference line.

### Medium Range

A distribution is identified as Medium Range when the point of maximum candela lies from **2.25 to 3.75 MH** from the luminaire's centerline, along the reference line.

### Short Range

A distribution is identified as Short Range when the point of maximum candela lies from **1.0 to 2.25 MH** from the luminaire's centerline, along the reference line.

### Very Short Range<sup>2</sup>

A distribution is identified as Very Short Range when the point of maximum candela lies from **0 to 1.0 MH** along the reference line.

<sup>1,2,3</sup> See page 41 for Footnotes

Distribution Types only generally describe a distribution pattern.

To establish the suitability of a luminaire for an application, evaluation must be completed using actual photometric data for the specific fixture and lamp combination being considered.

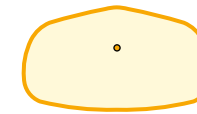

### Type II Horizontal Lamp

A distribution is classified as **Type II** when the **50% maximum candela trace lies within 1.75 MH** on the street side of the reference line.<sup>4</sup>

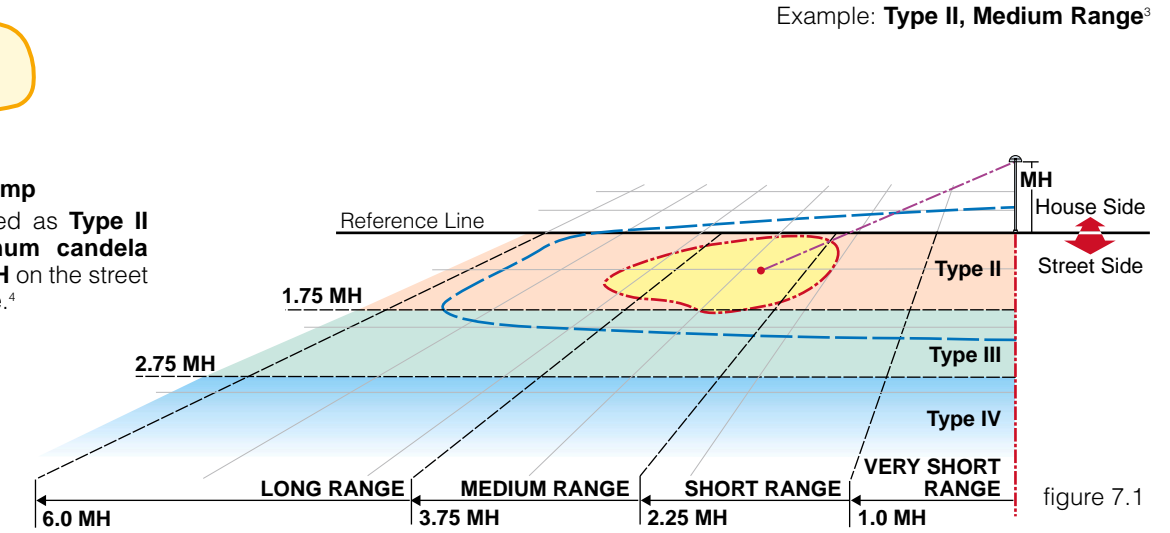
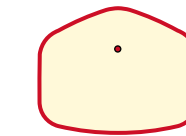

figure 7.1



### Type III Horizontal Lamp

A distribution is classified as **Type III** when the **50% maximum candela trace lies within 2.75 MH** on the street side of the reference line.<sup>4</sup>

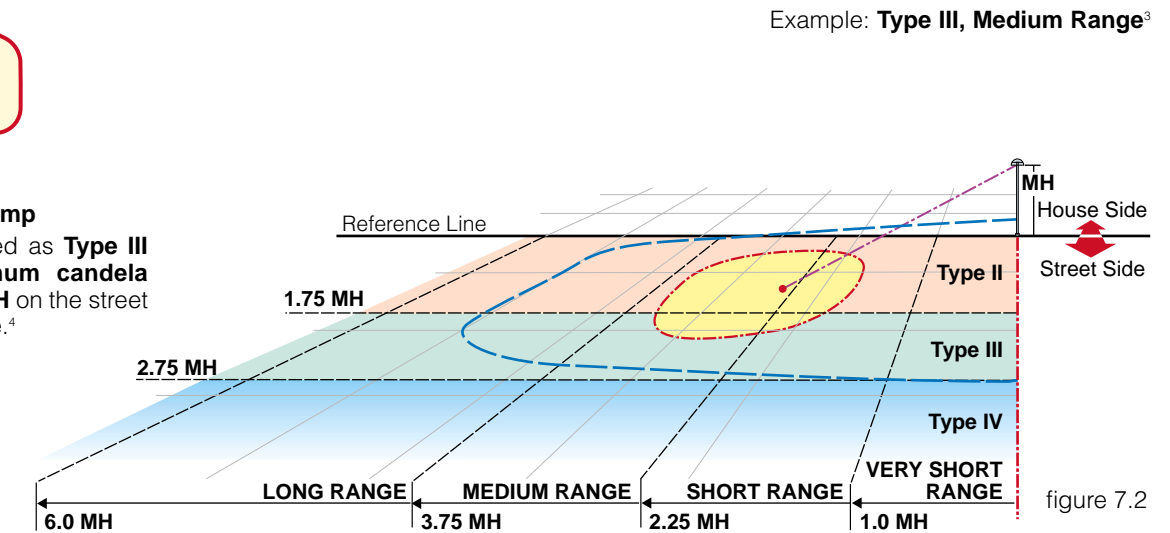
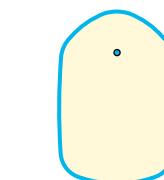

figure 7.2



### Type IV Horizontal Lamp

A distribution is classified as **Type IV** when the **50% maximum candela trace lies beyond 2.75 MH** on the street side of the reference line.<sup>4</sup>

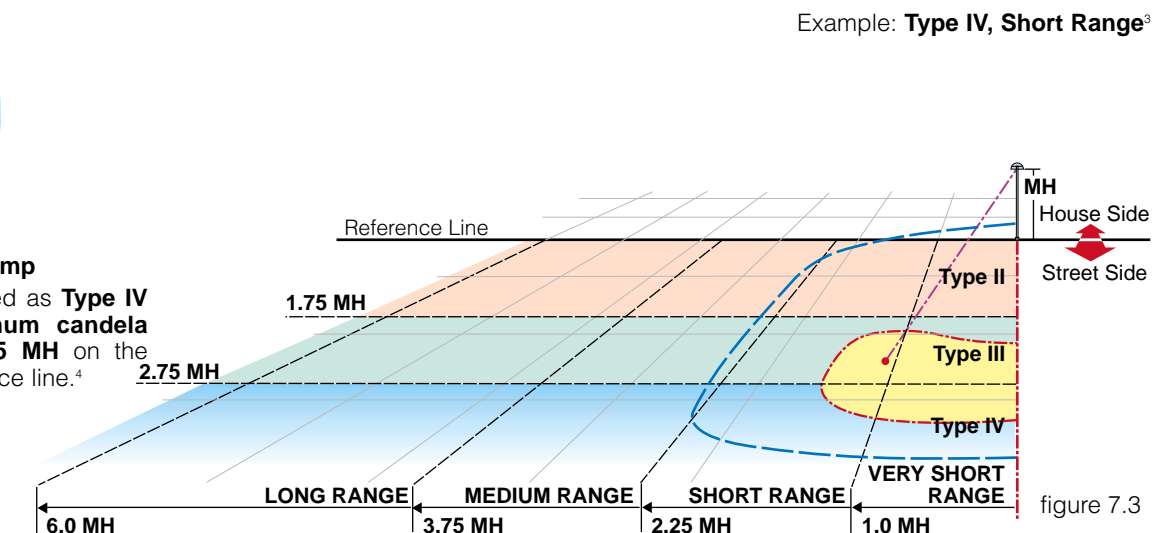
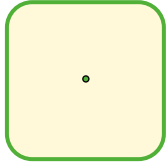

figure 7.3

<sup>3,4</sup> See page 41 for Footnotes

# Distribution Types

## Definitions



**Type V Square<sup>5</sup>  
Horizontal Lamp**

Distribution is classified as Type V Square for horizontal lamp luminaires when the **50% maximum candela trace is symmetric in four quadrants**. This distribution is characterized by four candela peaks, diagonal to the reference line.

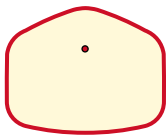
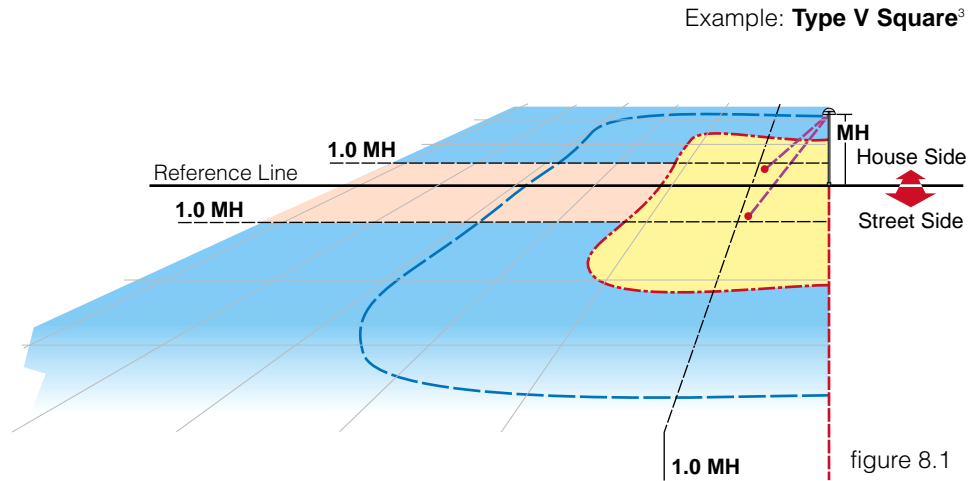

**Asymmetric<sup>5, 6</sup>  
Vertical Lamp**

General pattern appearance is similar to Type III. Distribution is classified as Asymmetric for vertical lamp luminaires when the **50% maximum candela trace lies beyond 1.0 MH** on the street side of the reference line, and inside 1.0 MH on the house side of the reference line. **Narrow Range distribution** is identified when the **point of maximum candela falls inside of 2.25 MH**, **Wide Range** is identified when the **point of maximum candela falls beyond 2.25 MH**.

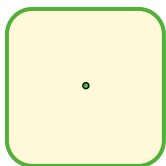
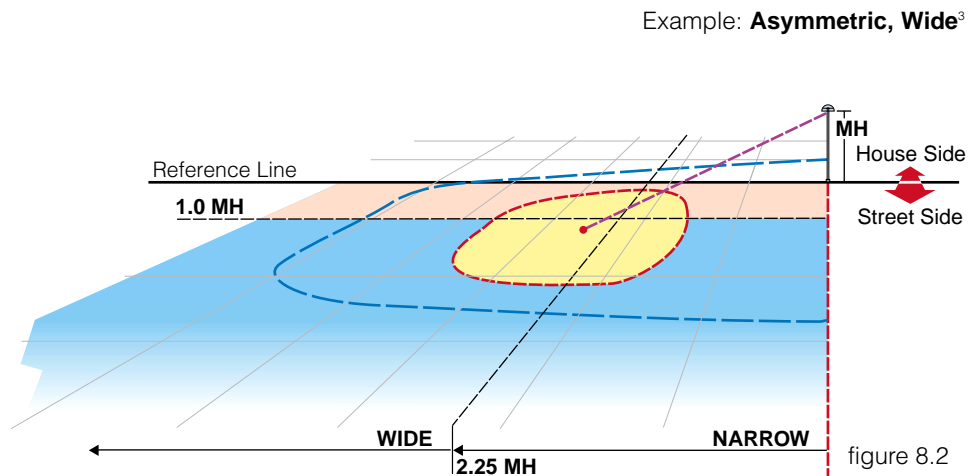

**Symmetric Square<sup>5, 6</sup>  
Vertical Lamp**

General pattern appearance is similar to horizontal lamp Type V Square. Distribution is classified as Symmetric Square for vertical lamp luminaires when the **50% maximum candela trace is symmetric in four quadrants** on both street and house side of the reference line. **Narrow Range distribution** is identified when the **candela peaks fall inside of 2.25 MH along the reference line**, **Wide Range** is identified when the **candela peaks fall beyond 2.25 MH**.

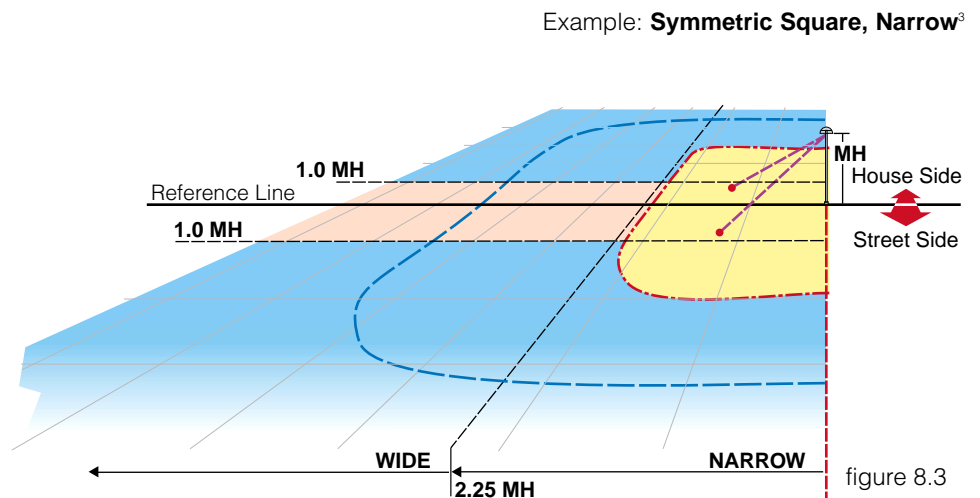

<sup>3, 5, 6</sup> See page 41 for Footnotes

# Definitions and Methodology



INDEPENDENT TESTING LABORATORIES, INC. • 3386 LONGHORN ROAD, BOULDER, CO 80302 USA • PHONE (303) 442-1255

FAX (303) 449-5274

REPORT NUMBER: ITL4-999  
DATE: 02/02/99  
PREPARED FOR: KIM LIGHTING INC.

	CANDELA TABULATION										
	STREET SIDE						HOUSE SIDE				
	0.0	15.0	35.0	55.0	71.0	75.0	90.0	115.0	135.0	155.0	180.0
180.0	0.	0.	0.	0.	0.	0.	0.	0.	0.	0.	0.
155.0	0.	0.	0.	0.	0.	0.	0.	0.	0.	0.	0.
125.0	0.	0.	0.	5.	0.	5.5	9.	9.	9.	0.	0.
115.0	0.	0.	0.	9.	0.	9.5	12.	12.	12.	0.	0.
105.0	4.	7.	9.	12.	9.	15.	15.	15.	15.	9.	12.
90.0	7.	9.	15.	15.	15.	18.	18.	18.	18.	12.	12.
80.0	18.	24.	27.	36.	36.	45.	36.	45.	55.	45.	36.
75.0	327.	491.	700.	1701.	4325.	4325.	1256.	500.	300.	518.	382.
66.0	728.	746.	2492.	4011.	8595.	8232.	4302.	1783.	1674.	1437.	1037.
65.0	782.	810.	2465.	4339.	6913.	8141.	4466.	1810.	1737.	1483.	1110.
55.0	1674.	1983.	2610.	4066.	4325.	6631.	3290.	2001.	2010.	1655.	1492.
45.0	2219.	2192.	2310.	2392.	1946.	2228.	1974.	1865.	1865.	1719.	1674.
35.0	2110.	2165.	2092.	2092.	582.	2047.	1956.	1910.	1846.	1774.	1746.
25.0	982.	964.	1137.	1674.	455.	1956.	1956.				
15.0	582.	600.	664.	655.	363.	600.	746.				
5.0	491.	491.	491.	491.		464.	418.				
0.0	363.	363.	363.	363.		363.	363.				

Example Luminaire **Rated Lamp Lumens = 16000**

figure 9.1

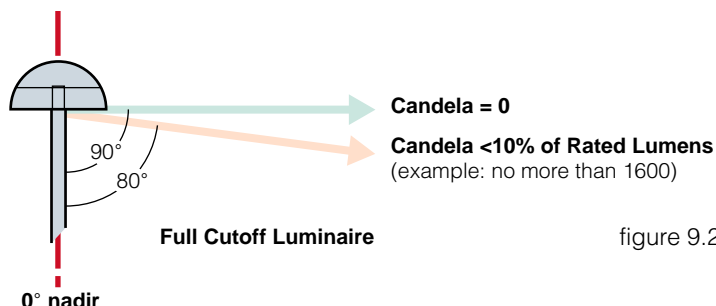

figure 9.2

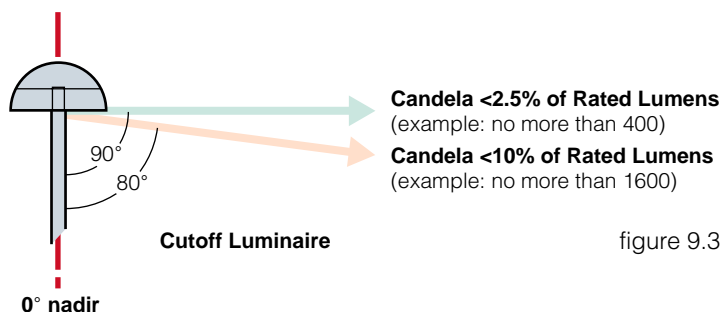

figure 9.3

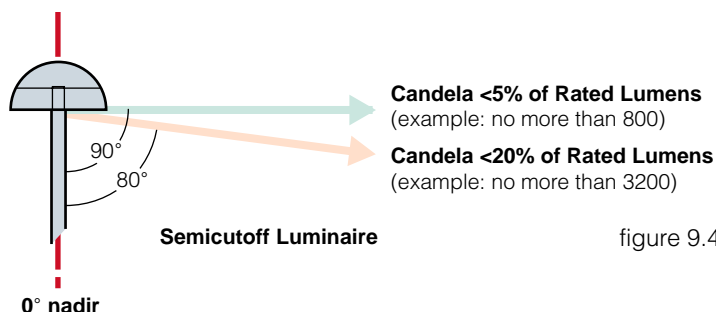

figure 9.4

## What is Cutoff?

Beyond distribution and range, luminaires are defined by how well they control light at angles above 80° from nadir.

Designs without significant cutoff characteristics distribute light in zones unlikely to contribute to useful visibility, contribute to light pollution, and are inefficient.

## Definitions

Definition of Cutoff is based on what proportion of a luminaire's output is being distributed at 80° and 90° above nadir.

### Noncutoff

A luminaire's light distribution is designated as Noncutoff when there is no luminous limitation in any zone.

### Full Cutoff

A luminaire's light distribution is designated as Full Cutoff when the candela at 90° above nadir is 0 and less than 10% of rated lumens at 80° above nadir.\* See figure 9.2

### Cutoff

A luminaire's light distribution is designated as Cutoff when the candela at 90° above nadir is less than 2.5% of rated lumens, and less than 10% of rated lumens at 80° above nadir.\* See figure 9.3

### Semicutoff

A luminaire's light distribution is designated as Semicutoff when the candela at 90° above nadir is less than 5% of rated lumens, and less than 20% of rated lumens at 80° above nadir.\* See figure 9.4

### Example:

The luminaire represented in the sample Candela Tabulation (figure 9.1) produces **18 candela at 90°** (<2.5% of Rated Lumens) and **55 candela at 80°** (<10% of Rated Lumens). These values fall within the defined ranges shown in figure 9.3, classifying this as a **Cutoff Luminaire**.

\* Extracted from IES Publication RP33-99 (2/99).

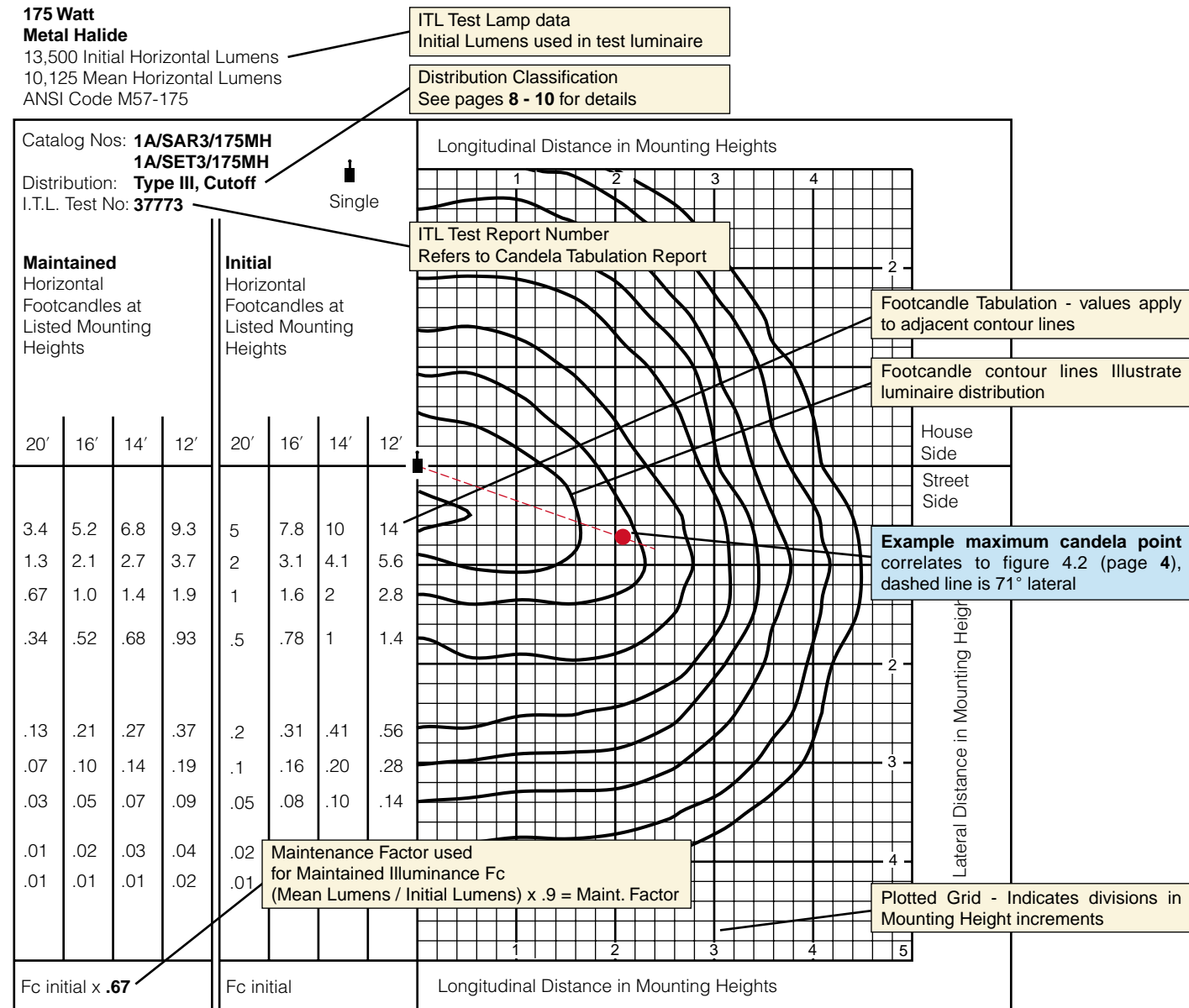

figure 10.1

**Conventions**

Footcandle calculations are shown with the luminaire at various mounting heights. Contour lines are drawn through illuminance values. Each contour, from the center out, represents approximately 50% of the value of the previous contour. The plot is placed over a grid, indicating mounting height divisions, to demonstrate the luminaire's applied performance.

**Usage**

The isofootcandle plots graphically represent the luminaire's lighting pattern, in illuminance, striking a horizontal surface. These plots are scalable as they are represented in mounting height increments. An approximation of pole spacings required to attain a desired uniformity can easily be determined from the information provided (see page 13 for details). These plots also provide a productive tool for the comparison of various luminaires. The easily read visual reference indicates beam patterns graphically, where other information (such as candela tabulations and isocandela curves) may be less clear.

**Example maximum candela point**

and lateral angle line is included here to illustrate how illumination levels at a point correlate with the Isofootcandle Plot information shown. The location of the point is 2.12 Mounting Heights lateral to the fixture reference line and .73 Mounting Heights from the Street Side. The point represents a calculated 2.95fc, which corresponds to its position between the 2fc and 4.1fc Isofootcandle contour lines (at a 14' Mounting Height).

**Estimating Maximum Spacing**

During the Schematic Design phase of a project, rough luminaire layouts can be created using isofootcandle plots.

**EXAMPLE**

This example assumes a desired **Minimum Initial Illuminance of 2.0fc**, using luminaires mounted on 14' poles.

To estimate a fixture layout - start from the perimeter, where the **2.0fc** isofootcandle trace crosses the Reference Line, to establish the maximum single fixture distance to the site perimeter (**1.6 MH**, figure 11.1).

In order to attain the minimum illuminance (2.0fc) between fixtures, the 1.0fc traces of two fixtures must intersect at the site perimeter and interior. Therefore, lateral spacing is determined by where the 1.0fc trace intersects the Reference Line (**2.2 MH**), and maximum forward spacing is identified where the lateral spacing line intersects the 1.0fc trace on the street side of the luminaire (**1.8 MH**). These two dimensions indicate the mid-points between luminaires, in Mounting Heights.

Multiplying these **Mounting Height** dimensions by the pole height (**14'**) defines the maximum luminaire spacings in both directions. In this example, **60'** (4.4 MH x 14') x **50.4'** (3.6 MH x 14').

**Approximate Illuminances**

By overlaying Isofootcandle Plots, a rough idea of illuminances can be accomplished by adding the values of each contour where they intersect (figure 11.2).

More accurate calculations (computer generated evaluations) will generally return levels higher than those achieved using this method, as smaller contributions from every adjacent luminaire would be included.

**Approximate Uniformity**

Through observation of the overlapping of the Isofootcandle Plots, approximate uniformity can also be estimated (figure 11.2).

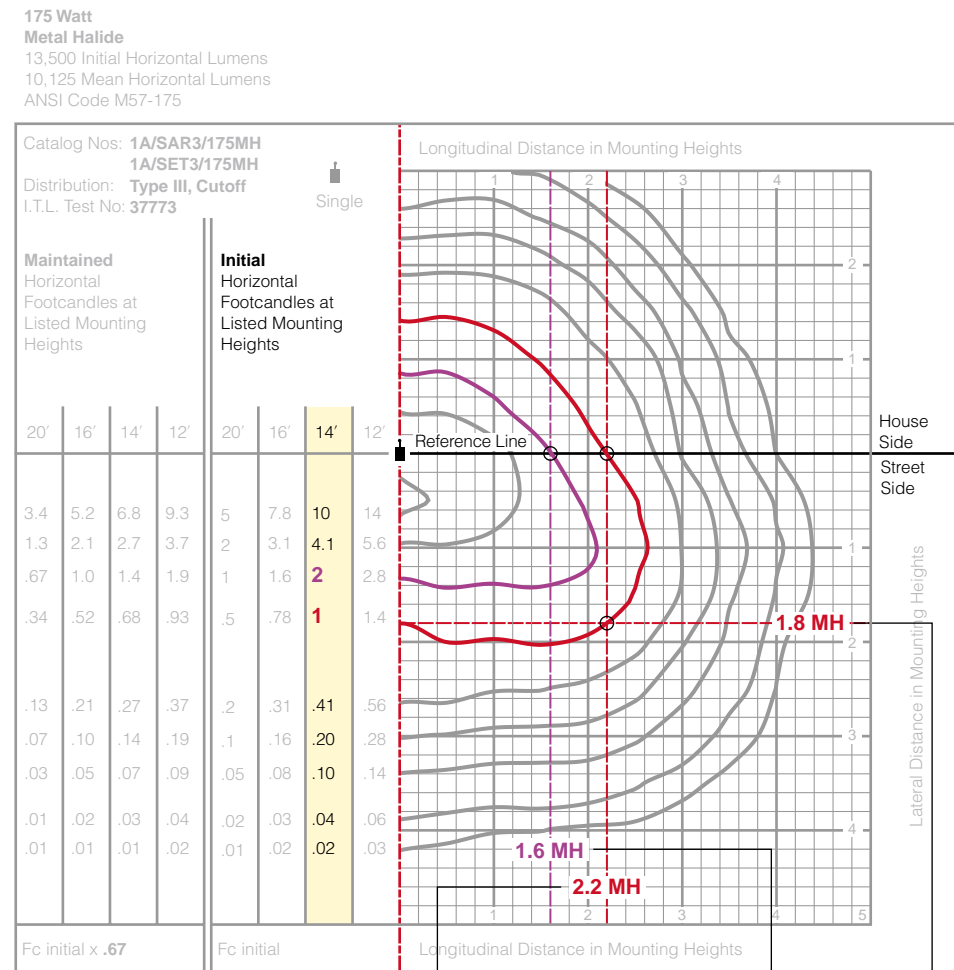

figure 11.1

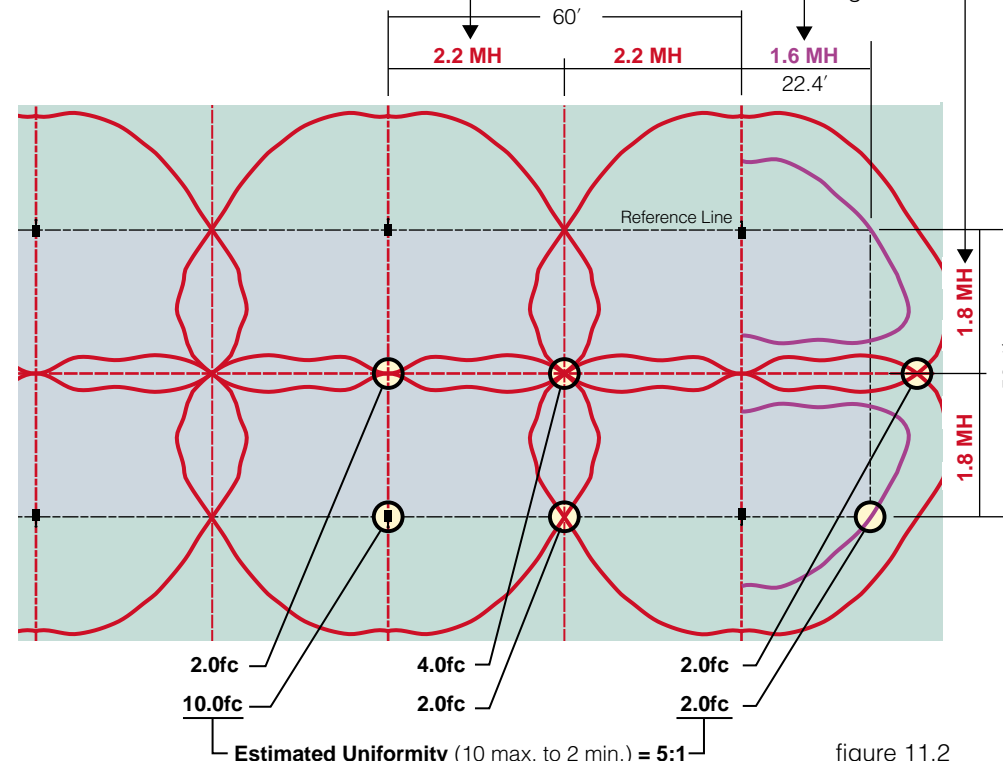

figure 11.2

<sup>3</sup> See page 41 for Footnotes

# Application

## Distribution Pattern Uses

### Estimating Maximum Spacing

Ideally, all light energy produced would be focused into desired "lighted" zones with no wasted energy being directed elsewhere. This would require an infinite array of distributions, with the ability to tune them to every site condition.

While this is not realistic, the combination of careful luminaire selection, mounting height, and luminaire placement, can produce very efficient designs, using just four basic distribution patterns.

For each of the basic distributions, variations such as range and the characteristics of horizontal vs. vertical lamp optics, produce additional choices. Further fine tuning can be attained with houseside shields and reflector orientation (see page 15).

The example below (figure 14.1) shows how the combination of four basic distribution patterns are used to direct light energy into the lighted zones.

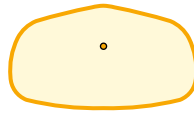

**Type II**

Type II distributions are well suited for narrow areas, running parallel to the luminaire's reference line, such as roadways, paths and driveways.

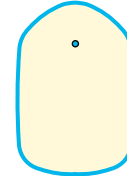

**Type IV**

Type IV distributions produce a deep forward throw, well suited for perimeter lighting.

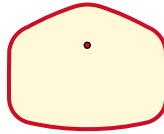

**Type III - Horizontal Lamp  
Asymmetric - Vertical Lamp**

Type III and Asymmetric distributions are well suited for site / area perimeters, wide roadways, and open areas.

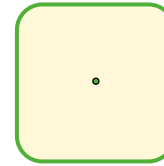

**Type V Square - Horizontal Lamp  
Symmetric Square - Vertical Lamp**

Type V and Symmetric distributions produce a wide, symmetrical pattern with excellent uniformity for large, open areas.

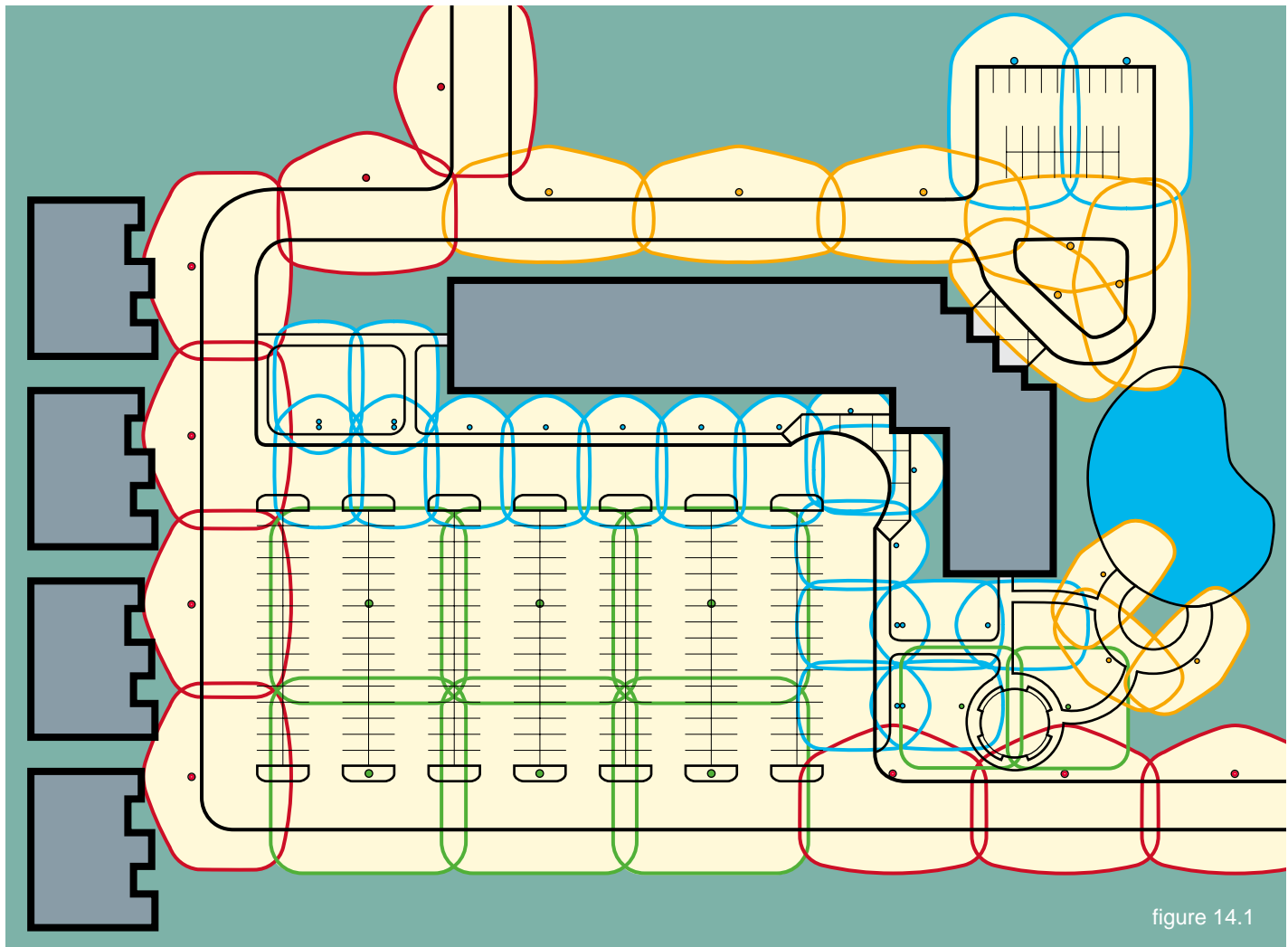
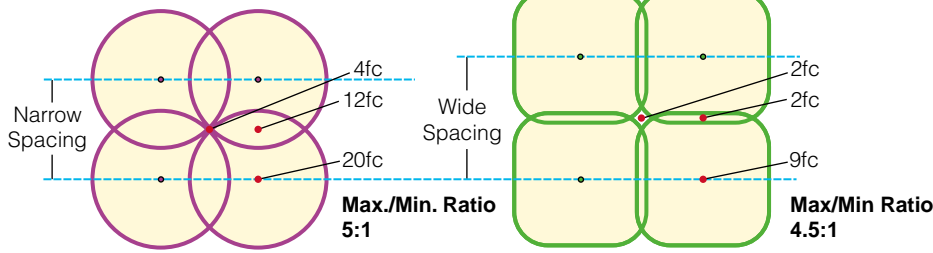

figure 14.1

# Important Features for Fine-Tuning Designs



## Typical Round Pattern Overlap

Poor diagonal overlap requires tighter pole spacing to maintain acceptable uniformity.

## Kim Type V Square Pattern Overlap

Improved diagonal overlap allows wider pole spacing while maintaining excellent uniformity.

## Square vs. Round Distribution

For large areas, symmetric distributions provide maximum pole spacing in both lateral and longitudinal directions. Round distributions, however, do not reach well diagonally between pole locations, reducing uniformity and requiring shorter distances between luminaires. Kim square distribution patterns are specifically engineered to maximize pole spacing by improving uniformity diagonally between fixture locations.

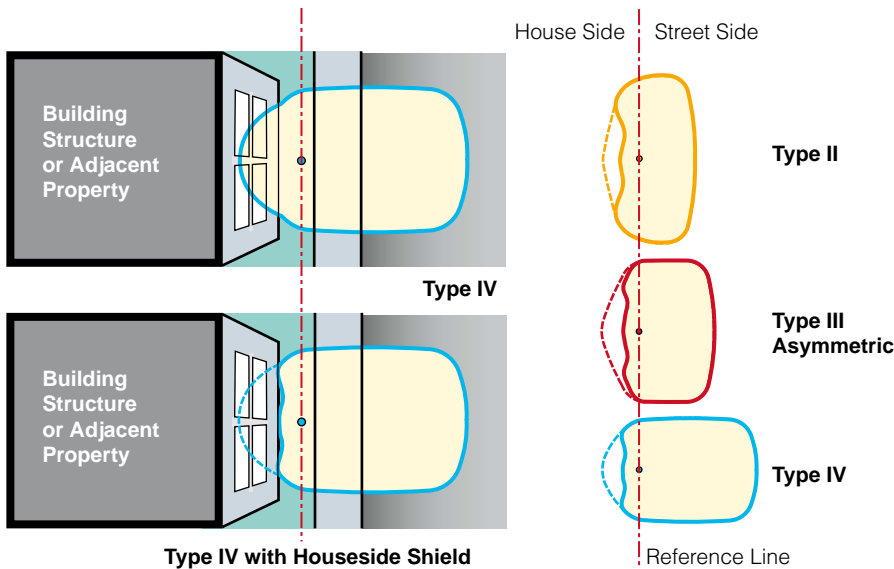

## Houseside Shields

When luminaires are located close to structures, or areas where the illumination emitted on the houseside of the reference line is objectionable, houseside shields offer additional control.

These devices “trim” light emitted by the lamp, as well as light reflected from within the optical system. These are applied to Type II, Type III and Type IV (horizontal lamp) and Asymmetric (vertical lamp) optical systems only.

Houseside shields are not applied to Type V or Symmetric optical systems, as they will not function properly.

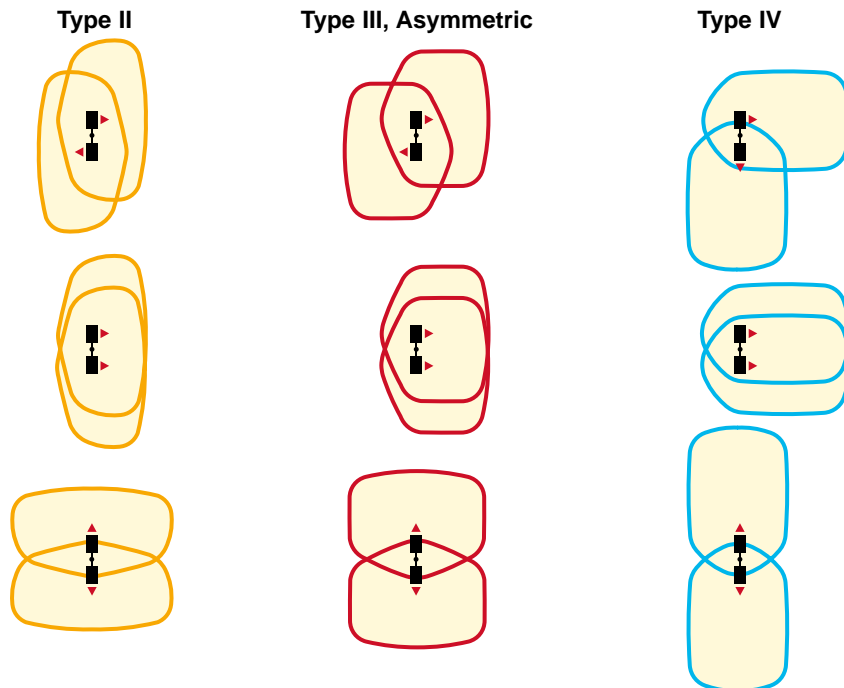

## Reflector Orientation / Rotatable Optics

Orientation of luminaires is often controlled by available pole locations and product aesthetic design. The luminaire head, arm or yoke may dictate an orientation that varies from the desired optical orientation.

The ability to rotate optical systems provides a high degree of flexibility to tailor luminaire performance to specific applications, while maintaining aesthetic continuity of the luminaires used.

The combination of optical distributions in multiple luminaire applications produces additional unique “footprints,” creating customized performance and/or increased illumination levels to suit a very wide range of needs.

The illustrations shown at left are just a few examples based on a simple twin mounting arrangement.

### Optical Design

The function of an optical system is to direct light energy emitted by the lamp into desirable luminous zones. This can be accomplished by reflection, diffusion, baffling, refraction, or transmission through a lens.

Lamp placement also plays a significant role in determining optical system performance. Lamps placed higher in reflector systems produce narrower distributions with very sharp cutoff control, while lamps placed lower in reflector systems produce wider distributions with less precise cutoff.

### Lamp Characteristics

Clear envelope H.I.D. sources do not produce significant output from the lamp ends (socket and bulb tip). This characteristic has a significant impact on optical system design.

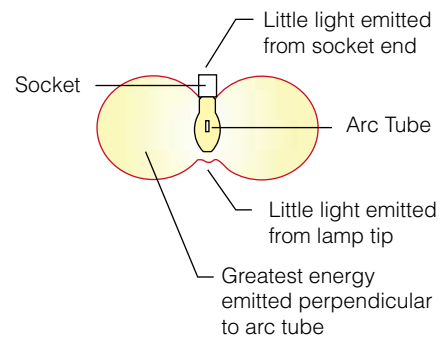

Lamp orientation and the design of reflector components use these characteristics to achieve the greatest end result.

### Lens Effects

As light strikes the surface of a flat lens, some portion is reflected back into the optical system. This is most apparent at shallow incident angles and impacts the ability of an optical system to spread light horizontally.

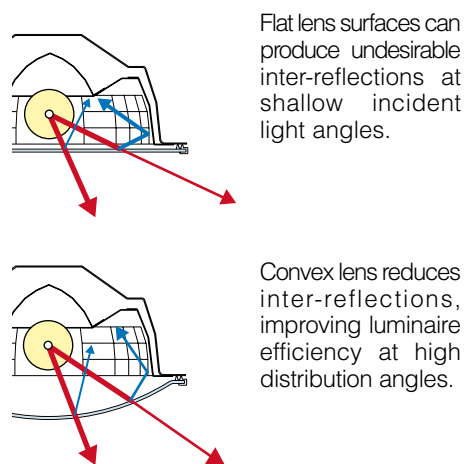

### Lamp, Reflector, and Lens Interaction

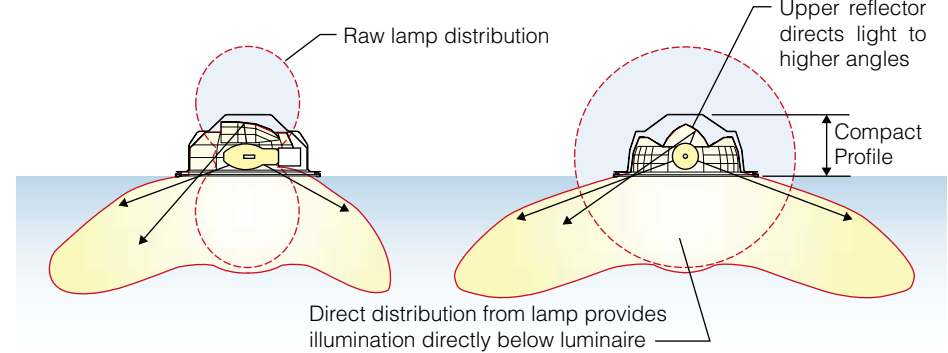

**Horizontal Lamp with Flat Lens** is well suited for asymmetric distributions with very sharp cutoff control.

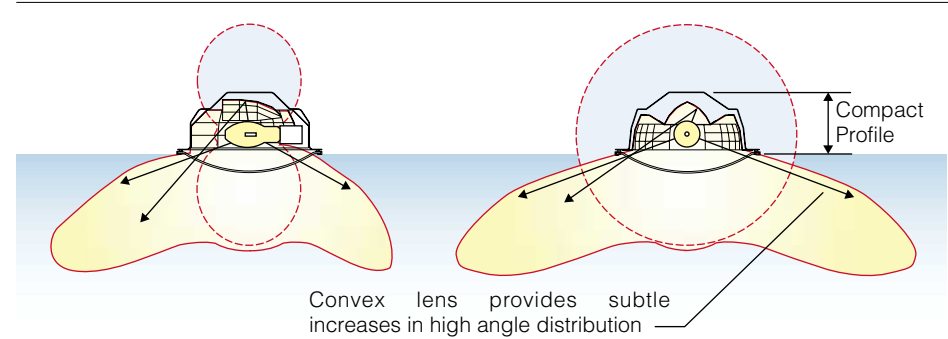

**Horizontal Lamp with Convex Lens** is well suited for asymmetric distributions with good cutoff control, where increased lens presence is desirable. A subtle improvement in uniformity is also realized.

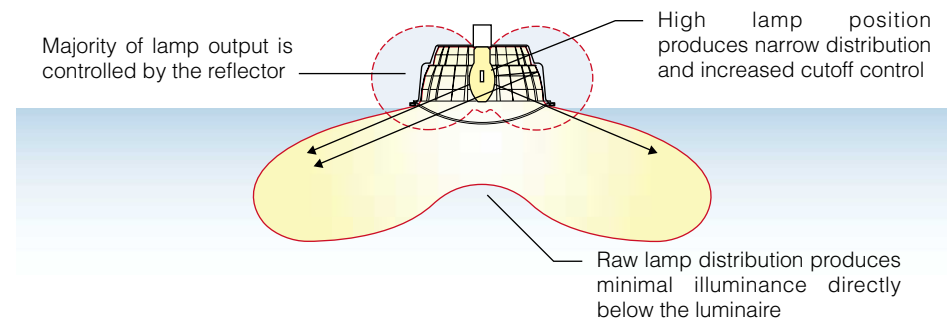

**High Vertical Lamp Position with Convex Lens** is well suited for narrow symmetric distributions with sharp cutoff control.

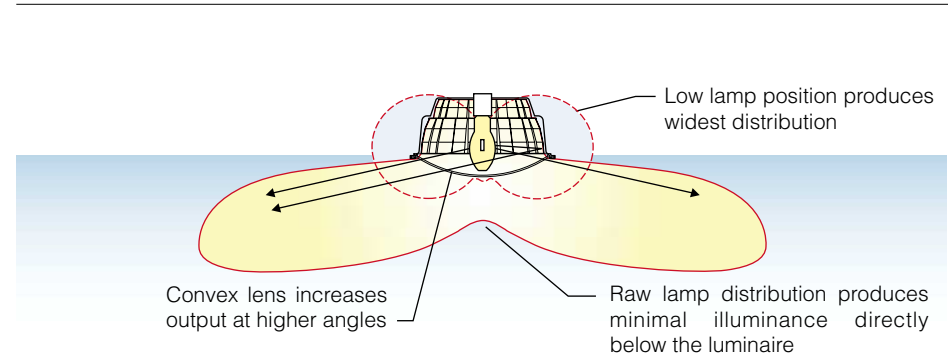

**Low Vertical Lamp Position with Convex Lens** is well suited for wide symmetric distributions.

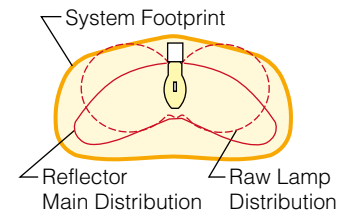

**Type II - Horizontal Lamp**

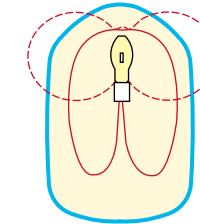

**Type IV - Horizontal Lamp**

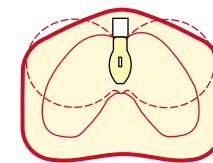

**Type III - Horizontal Lamp**

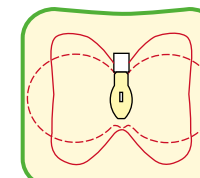

**Type V Square - Horizontal Lamp**

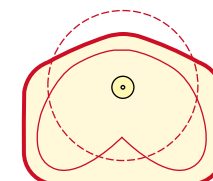

**Asymmetric - Vertical Lamp**

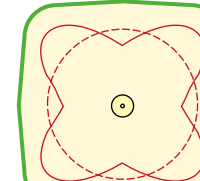

**Symmetric Square - Vertical Lamp**

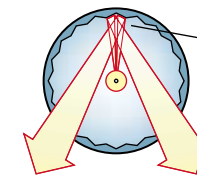

Vertical lamp reflector design redirects light energy away from the arc tube center by "splitting" distribution using reflector facets

### Orientation

Using the lamp's natural distribution to its greatest advantage produces the most effective optical designs. In plan view, the horizontal lamp orientation produces asymmetric lateral distribution, while vertical lamp orientation produces a strong symmetric pattern. Reflector designs that enhance these characteristics produce the most efficient results.

### Horizontal Lamp Orientation

Horizontal lamp orientation provides the greatest control over lateral distribution. The normal lamp distribution is very well suited for asymmetric as well as square symmetric distribution. Horizontal lamp orientation produces relatively small arc tube exposure to high distribution angles. This produces a superior cutoff characteristic.

### Vertical Lamp Orientation

Vertical lamp orientation subjects the greatest portion of the lamp's output to control by the reflector system, producing optimum vertical distribution control. This orientation provides less control over lateral output, favoring symmetric distribution patterns. Vertical lamp orientation also takes advantage of the higher lumen output produced by a vertical arc tube positioning.

Kim's split beam optical features produce the optimum optical system performance by reducing energy being redirected through the arc tube and lamp envelope. This also reduces damaging arc tube voltage rise in High Pressure Sodium sources.

### Houseside Shields

The effects of lamp orientation and lens configuration on houseside shields are dramatic.

Main reflector distribution, street-side reflector brightness, and direct lamp visibility are factors that determine the effectiveness of houseside shields in reducing unwanted brightness on the house-side of the optical system.

Horizontal lamp orientation presents the greatest challenge in designing effective shielding. Convex lenses allow more effective control, as the shielding device is able to better control direct arc tube brightness. Vertical lamp orientation provides even greater control, as the arc tube is already deeper in the optical system.

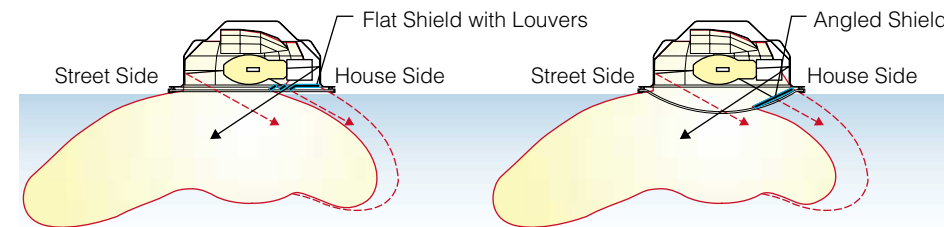

**Horizontal Lamp with Flat Lens:** Least effective shielding

**Horizontal Lamp with Convex Lens:** Effective shielding

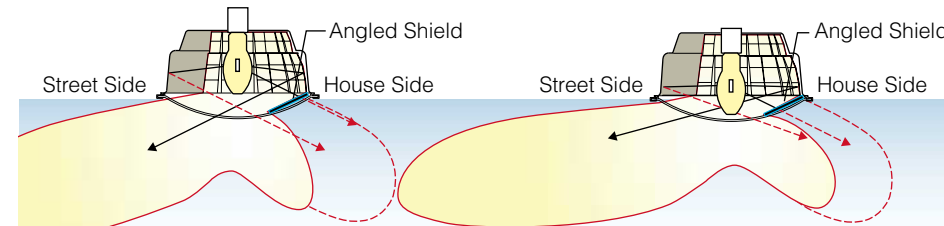

**High Vertical Lamp Position with Convex Lens:** Most effective shielding

**Low Vertical Lamp Position with Convex Lens:** Very effective shielding

# Reflector Mechanical Design

## General Methods of Construction

### Reflector Construction

Reflectors can be constructed using several methods; hydroforming, stamping, spinning, segmented strips and fabrication. The greatest difference between methods lies in how the reflective surfaces are finished and how precise the reflector elements are shaped and held in place.

Hydroforming, stamping, and spinning begin from raw, unfinished sheet metal, which is formed, then finished in one piece. The material used in these methods often compromises reflectivity to accommodate forming and finishing of the component. The shape of the reflector segments, corner radii and surface texture are also affected by these forms of manufacture, at the cost of performance.

Pre-finished optical reflector sheet offers much higher reflectivity than any post-form finishing. The variety of reflective qualities and surface textures produces the greatest level of design control. These materials are alloyed to improve reflective qualities and are finished to very tight tolerances, using computer controlled machine processes. The pre-finished surface, however, cannot be hydroformed, spun or stamped, as this destroys the reflective qualities and durability of the material.

Reflectors made from pre-finished reflector materials must be carefully formed and fastened to create an optical assembly.

Strip segment reflector assemblies utilize pre-finished lighting sheet, cut into strips, break formed and riveted along a single edge to a lightweight backing pan. While inexpensive to manufacture, these assemblies can easily be distorted during regular maintenance.

### Fabricated Construction

Fabricated optical systems utilize pre-finished, interlocking reflector elements that are fastened by tabs and rivets to a rigid frame. These systems offer high levels of repeatability in manufacturing with accurate placement of reflector elements. Fabricated systems are durable and able to withstand regular maintenance.

**Kim Lighting utilizes fabricated reflector systems.** This method combines the best available reflector materials with the most precise and durable location of elements within the optical system.



### Hydroforming, Stamping, or Spinning

Reflectors created with these forming methods require the addition of draft-angles for tool release and large corner radii. These requirements often result in a compromise to optical design. Final finishing of these components may suffer unevenness in corners and bends. While producing consistent shape and allowing easy sealing of the optical chamber, these forming methods do not offer the precision of pre-finished lighting sheet. These forming methods are well suited to small scale optical systems, where compact design is more critical than optimum output.

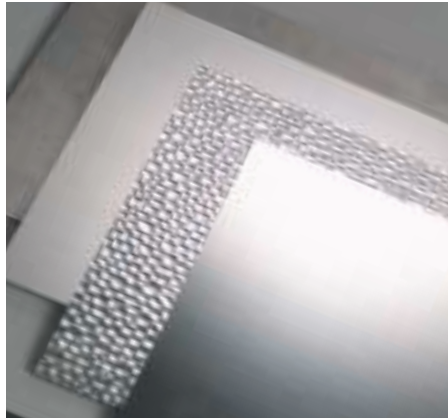

### Pre-finished Lighting Sheet

Pre-finished optical sheet materials offer the most precise surface finish, optical quality, surface durability and consistency. These materials are alloyed and finished specifically to produce the reflective qualities. Reflectivity can be as high as 98%, with optical clarity near that of scientific first-surface mirrors. The availability of a wide range of finishes (specular to diffuse) and surface textures (flat to heavily dimpled), provides the opportunity to create very precise optical systems, not possible with other forming methods.



### KIM Fabricated Construction

Using a combination of pre-finished materials, formed, interlocked and riveted to a rigid frame, this method of construction creates a robust optical system. Each reflector element is held firmly and precisely in place. The three dimensional attributes of this design also increase efficiency by controlling a larger portion of lamp output. These systems are tough enough to be cleaned and will withstand years of regular maintenance with no degradation of performance or precision.

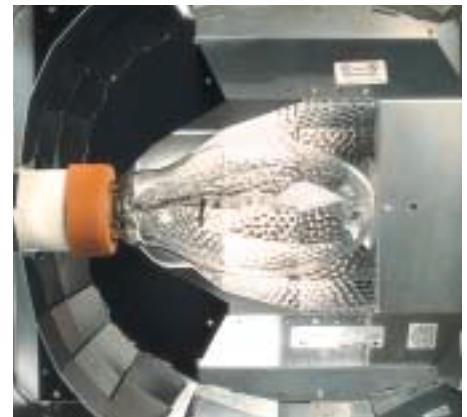

## Fabricated Construction Features

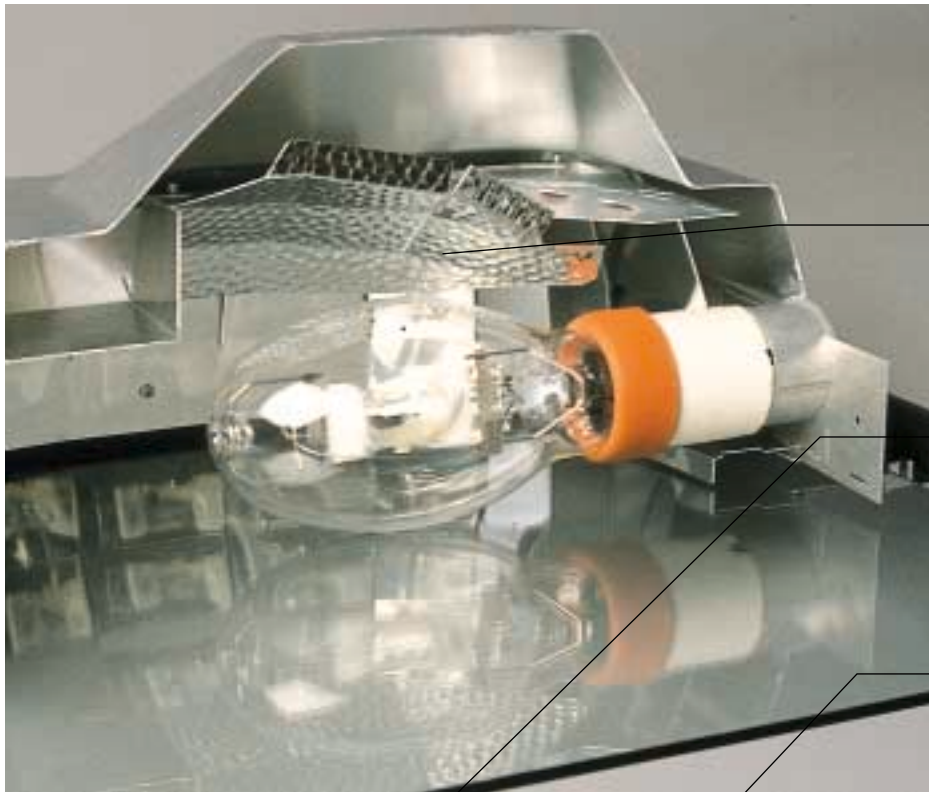

### Premium Materials

Kim uses the highest quality pre-finished reflector materials available, from the premier suppliers of lighting quality sheet stock. Reflector surfaces are protected by plastic film throughout the manufacturing and assembly process.

### Class A Tool Tolerances

All tools used to form the optical components are Class A, producing the sharpest possible bend radii, which eliminates undesirable inter-reflection caused by soft or large radius corners in an optical system.

### Fastening

All reflector elements are secured by tabbing into the carrier frame and adjacent elements, then riveted to provide a permanent attachment. These one-way fitments assure consistency in fabrication and resistance to deformation during maintenance.

### Rigid Frame

Kim reflectors are constructed using rigid frames. Die-cast, spun, or hydroformed, these create the foundation for the optical components and must be rigid. All frames are finished by chemical etching or anodizing for corrosion resistance.



### Pure Silicone Gasketing

Premium molded gasket material produces the optimum seal and eliminates out-gassing, which can fog or haze the reflector system and lens. Silicone also has the highest memory retention for a repeatable seal after every lamping. All lens frame gaskets are molded in one piece, or extruded with the ends fused to produce a continuous loop, to eliminate gaps that allow intrusion of foreign objects into the optical system.

### Sealed Optical Chamber

Water, moisture, insects, dust, and other airborne debris will degrade luminaire performance if not eliminated. Infiltration can come through the pole arm, ballast compartment, lens seal, housing and door frame seams.

Kim eliminates infiltration by sealing the optical chamber inside and out, from all other components and cavities. The optical system is sealed against the lens or housing and held in place by a rigid die-cast door frame. All other penetrations, for wire or fasteners, are also sealed. This isolates the optical chamber completely and eliminates penetration of contaminants.

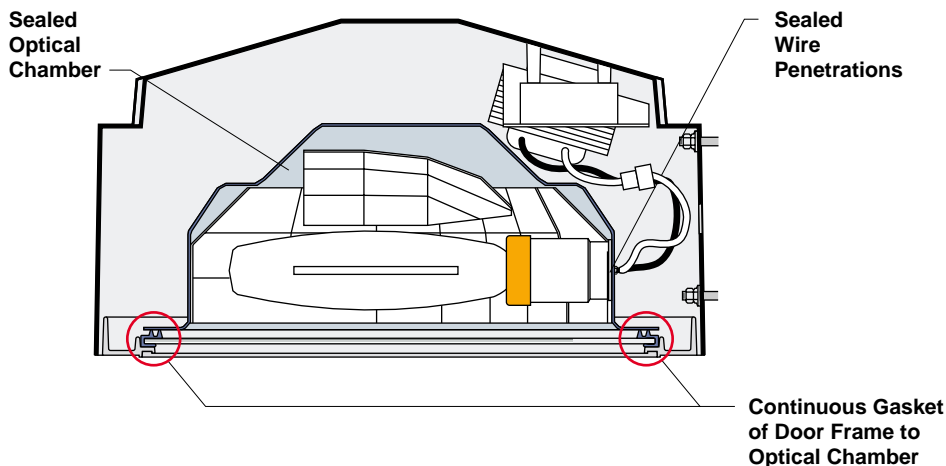

# Kim Optical Systems

## Three Core Systems for Maximum Adaptability

### Horizontal Lamp

**Horizontal lamp, with a flat lens.**  
Available in Type II, Type III, Type IV and Type V Square distributions. This system provides **maximum cutoff control** and very good uniformity.

An **Optional Convex Lens** provides increased lens presence and a subtle improvement in uniformity, while maintaining good cutoff characteristics.

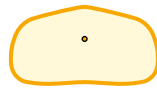
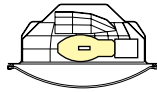
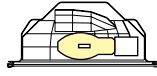

Type II

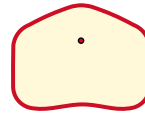

Type III

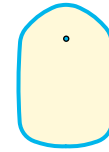

Type IV

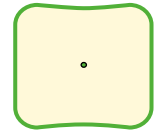

Type V Square

### Two-Tier Vertical Lamp

**Vertical lamp with convex lens, High or Low lamp position.**  
Available in Asymmetric and Symmetric distributions in wide and narrow ranges. Provides exceptional uniformity with **very wide pole spacings**. 70 to 1000 watt sources.

Initial lamp position is factory preset per specification. Socket positioning is controlled mechanically to positively locate the lamp during normal operation and maintenance.

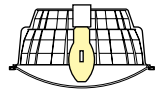
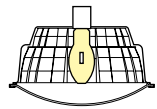

High Lamp Position

Low Lamp Position

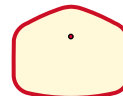

N3  
Asymmetric -  
Narrow

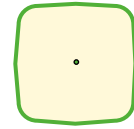

N5  
Symmetric Square -  
Narrow

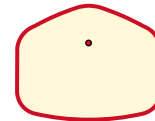

W3  
Asymmetric -  
Wide

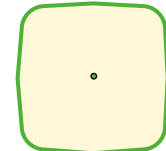

W5  
Symmetric Square -  
Wide

### Single-Tier Vertical Lamp

**Vertical lamp with convex lens.**  
Available in Asymmetric and Symmetric distributions. Provides vertical lamp performance in **compact luminaire profiles** unable to accommodate the larger Two-Tier system.

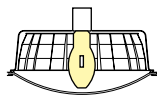

Fixed  
Low Lamp  
Position

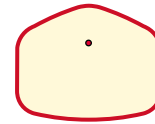

F3  
Asymmetric

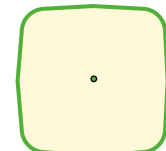

F5  
Symmetric Square

### Rotatable Optics

Kim products provide easy in-field rotation of the optical system within the luminaire. Every reflector is boldly marked to indicate major distribution orientation.

This allows optical performance to be adjusted independent of the luminaire's aesthetic elements, as well as the creation of unique distributions using multiple fixtures.

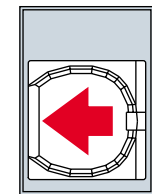
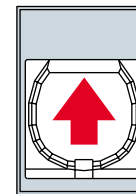
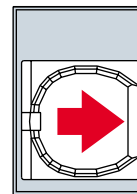
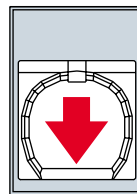

### Registered Quality Process

Kim Optical Systems are **Audited to ISO9001 Standards** at Kim operated facilities. This assures that procedures are in place, well documented and controlled, to produce a consistent quality experience for every Kim customer.



### Independent Testing

Kim photometry is accomplished by independent testing professionals, at **ITL Boulder**. This assures that any photometry data provided is accurate and attained using industry standard practice, seasoned lamps, and standardized ballasts, in a laboratory environment.





# Kim Horizontal Lamp Luminaires



## The Archetype®

**AR** – 150-400 HPS  
175-400 MH  
**SAR** – 70-150 HPS  
70-175 MH

**Type II, Type III, Type IV, and Type V Square**



## Curvilinear Cutoff

**17, 21, 25, and 29" Diameters**  
**CC/CCS** – 70-1000 HPS  
70-1000 MH

**Type II, Type III, Type IV, and Type V Square**

Also available with Vertical Lamp Optics.



## The Entablature®

**ET** – 150-400 HPS  
175-400 MH  
**SET** – 70-150 HPS  
70-175 MH

**Type II, Type III, Type IV, and Type V Square**



## Wide Throw Horizontal

**WTH** – 150-250 HPS  
175-250 MH

**Type II, Type III, Type IV, and Type V Square**

Also available with Vertical Lamp Optics.



## Matrix™

**MX21** – 150-400 HPS  
175-400 MH

**Type II, Type III, Type IV, and Type V Square**

Also available with Vertical Lamp Optics.



## NeoSphere®

**NS1** – Hemispherical Lens  
**NS2** – Flat Lens  
70-150 HPS  
70-175 MH

**Type II, Type III, Type IV, and Type V Square**

Also available with Vertical Lamp Optics.



# Kim Vertical Lamp Luminaires



## Matrix™

**MX21** – 150-400 HPS  
175-400 MH

**Symmetric and asymmetric distributions**

Post Top and Arm Mounted



## NeoSphere®

**NS1** – Hemispherical Lens  
70-150 HPS  
70-175 MH

**Symmetric and asymmetric distributions**



## VL Curvilinear

**17, 21, 25, and 29" Diameters**

**VL** – 70-1000 HPS  
70-1000 MH

**Symmetric and asymmetric, wide and narrow distributions**



## Wide Throw Vertical

**WTV** – 150-250 HPS  
175-250 MH

**Symmetric and asymmetric distributions**





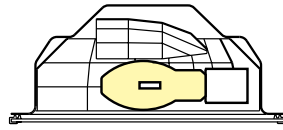

## Horizontal Lamp Flat Lens

(Also available with  
Optional Convex Lens)

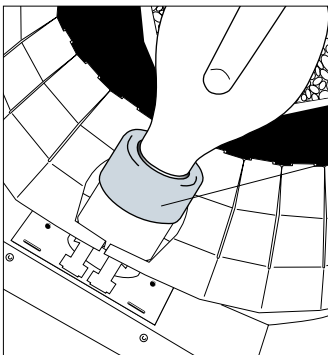

All Kim Horizontal MH sockets are pin-oriented (except pulse start) and include a molded silicone lamp stabilizer.

Molded Lamp Stabilizer

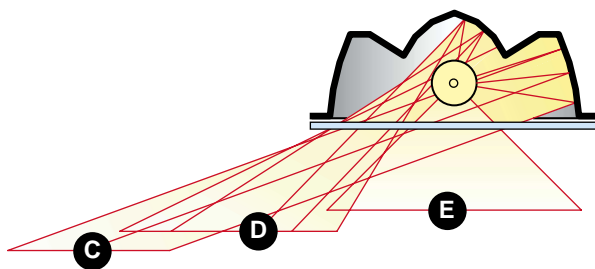
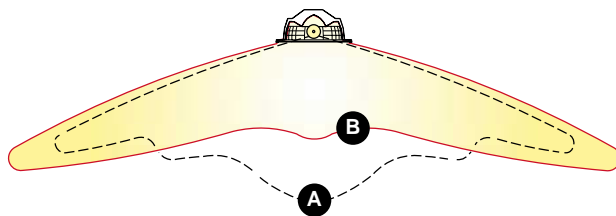

The horizontal lamp orientation with flat glass lens produces sharp cutoff with **zero light above 90°**. In addition, this system has been carefully engineered to provide maximum pole spacing with very good uniformity. The primary reflector panels are highly specular to achieve precise lamp arc reflections toward the desired areas on the ground. Excessive illumination below the luminaire is avoided by the elimination of downward reflecting surfaces.

- A** Typical horizontal lamp “Shoebbox luminaires” produce excessive straight-down illumination in relation to side throw. This causes poor uniformity and requires closer pole spacings.
- B** The Kim system has reduced straight-down illumination and increased side throw. This produces greatly improved uniformity and increased pole spacing.
- C** High angle maximum candela and sharp cutoff are produced by the smooth specular side panel elements.
- D** Mid range and transition distribution is produced by the specular peened upper reflector, gradually increasing intensity toward higher angles, while avoiding dark spots and low angle distribution.
- E** Low angle distribution from bare lamp output is more than adequate. The elimination of downward reflecting surfaces greatly improves uniformity by maintaining optimum low angle output.

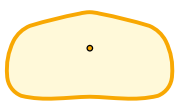

Type II

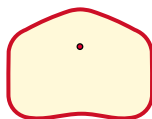

Type III

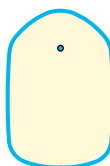

Type IV

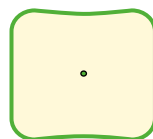

Type V Square

**70 - 400 Watt MH**  
**70 - 400 Watt HPS**

# Horizontal Lamp

## Type II - Medium Range

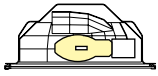
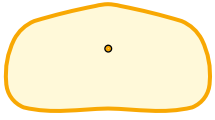

Horizontal Lamp  
Flat Lens  
Cutoff

### 400 Watt Metal Halide

40,000 Initial Horizontal Lumens  
32,000 Mean Horizontal Lumens

REPORT NUMBER: **ITL 35903**  
DISTRIBUTION: **Type II**  
REFLECTOR: **Multi-faceted - peened reflector above lamp, multi faceted specular reflector, diffuse former**

MAXIMUM PLANE AND CONE PLOTS OF CANDELA

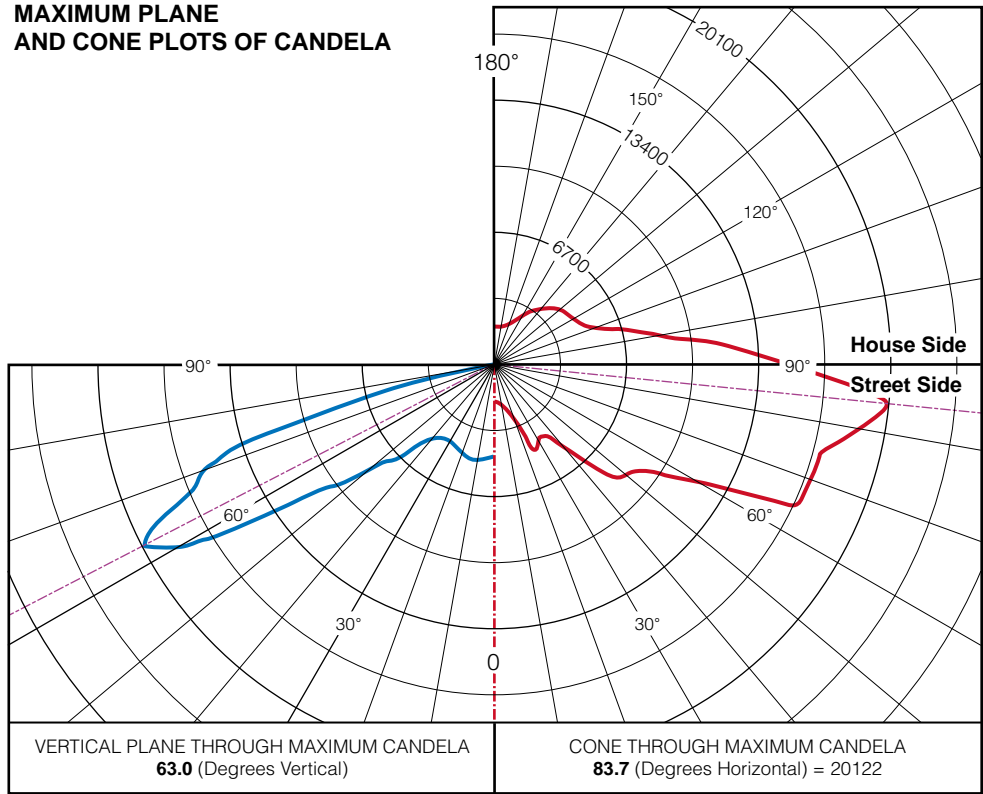

ISOFOOTCANDLE PLOT

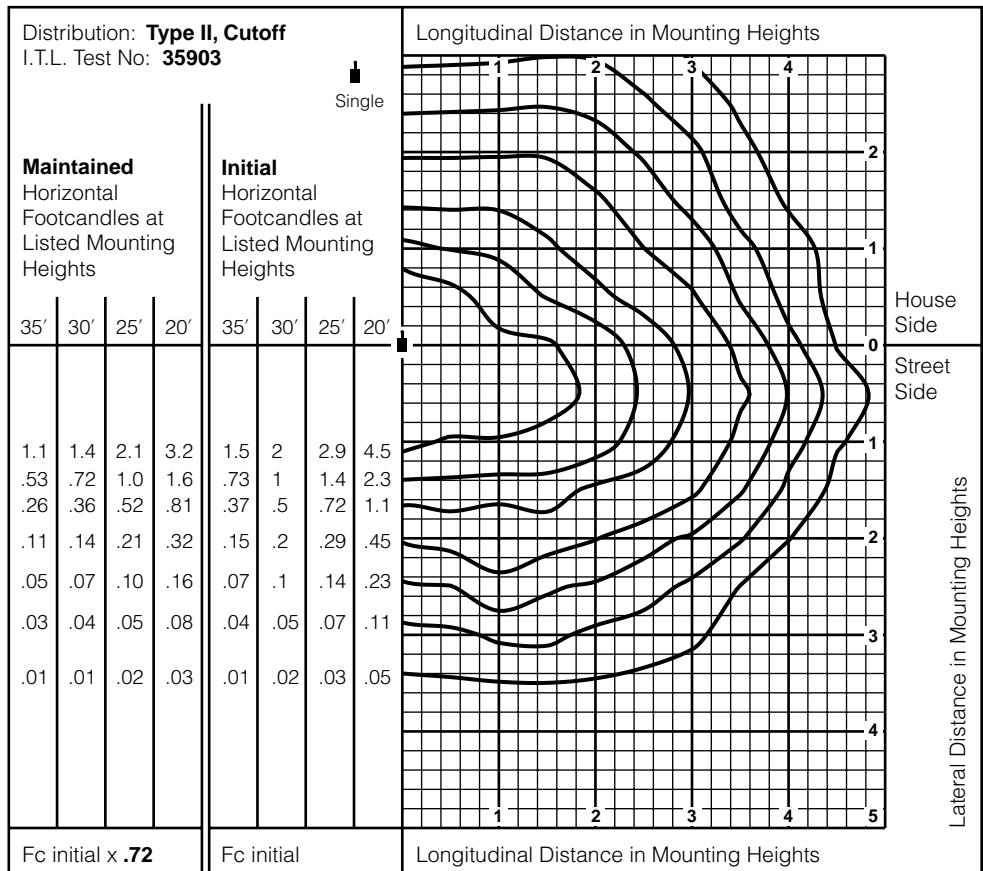

## Type III - Short Range

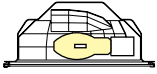
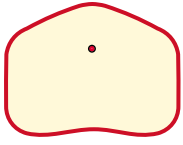

Horizontal Lamp  
Flat Lens  
Cutoff

### 400 Watt Metal Halide

40,000 Initial Horizontal Lumens  
32,000 Mean Horizontal Lumens

REPORT NUMBER: **ITL 35914**  
DISTRIBUTION: **Type III**  
REFLECTOR: **Multi-faceted - peened reflector above lamp, multi faceted specular reflector, diffuse former**

#### MAXIMUM PLANE AND CONE PLOTS OF CANDELA

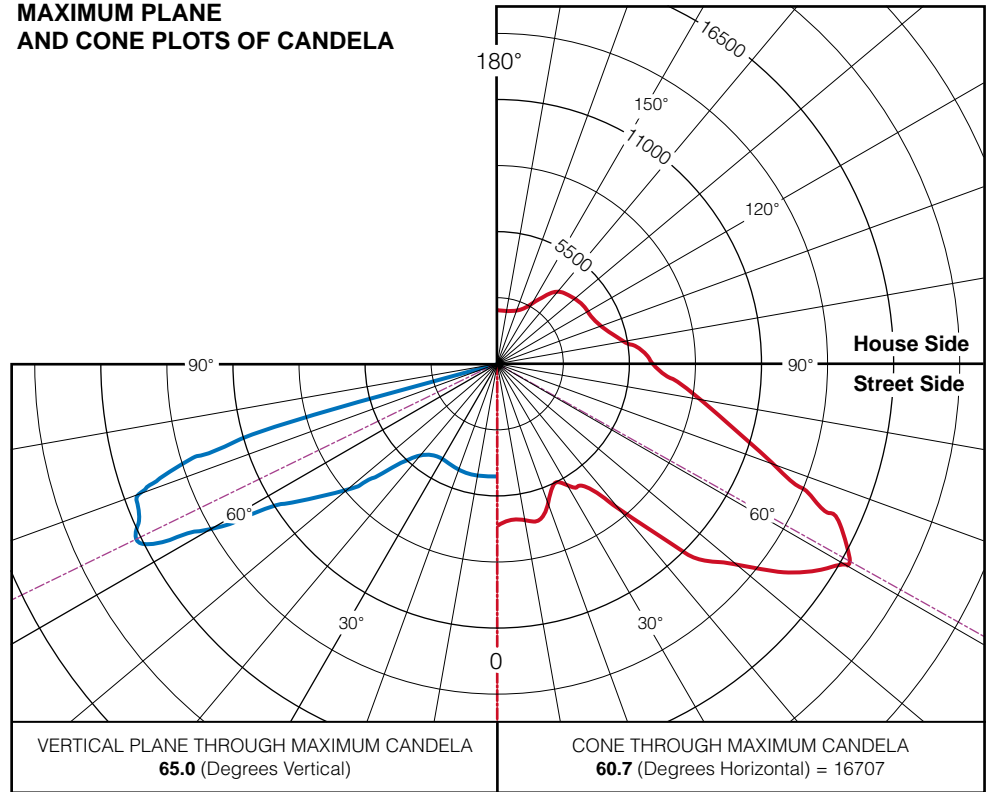

#### ISOFOOTCANDLE PLOT

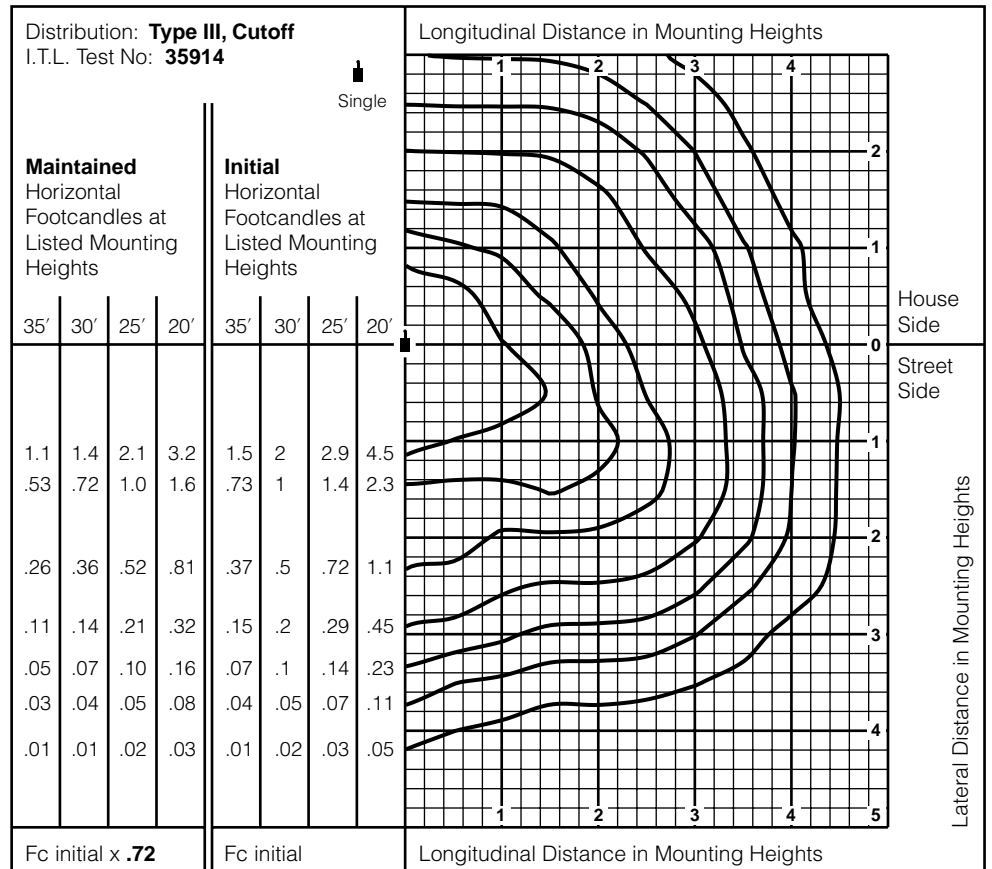

# Horizontal Lamp

## Type IV - Very Short Range

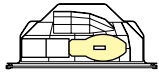
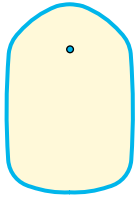

Horizontal Lamp  
Flat Lens  
Cutoff

**400 Watt  
Metal Halide**

40,000 Initial Horizontal Lumens  
32,000 Mean Horizontal Lumens

REPORT NUMBER: **ITL 35925**  
DISTRIBUTION: **Type IV**  
REFLECTOR: **Multi-faceted - peened reflector above lamp, multi faceted specular reflector, diffuse former**

**MAXIMUM PLANE  
AND CONE PLOTS OF CANDELA**

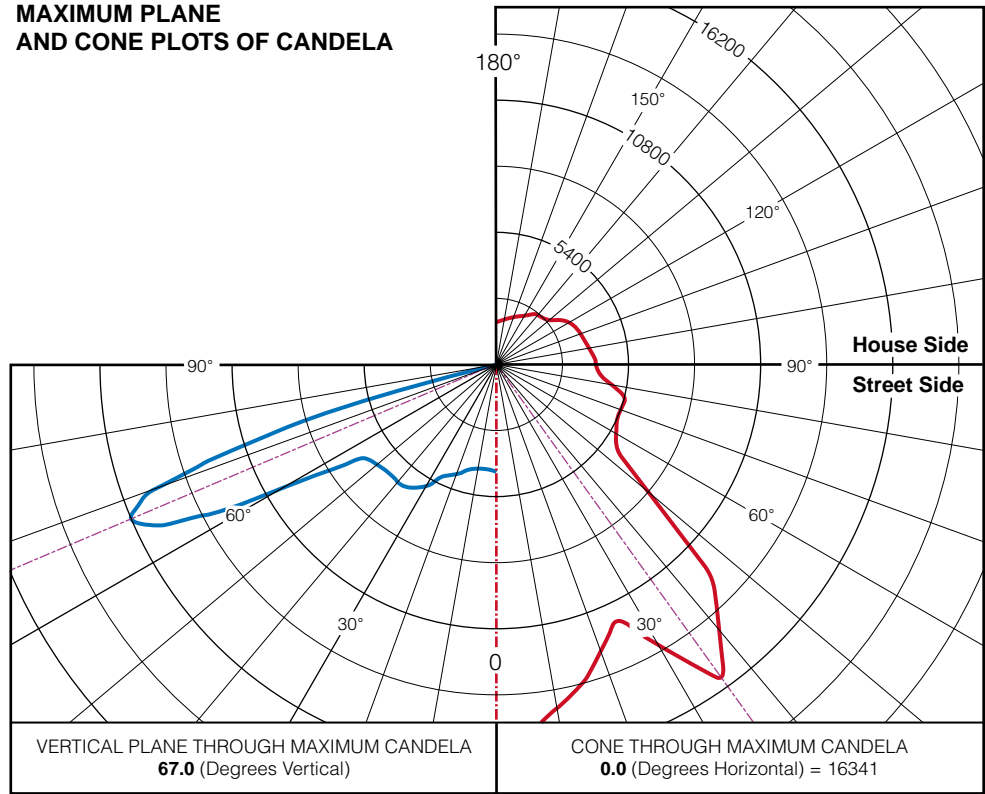

**ISOFOOTCANDLE PLOT**

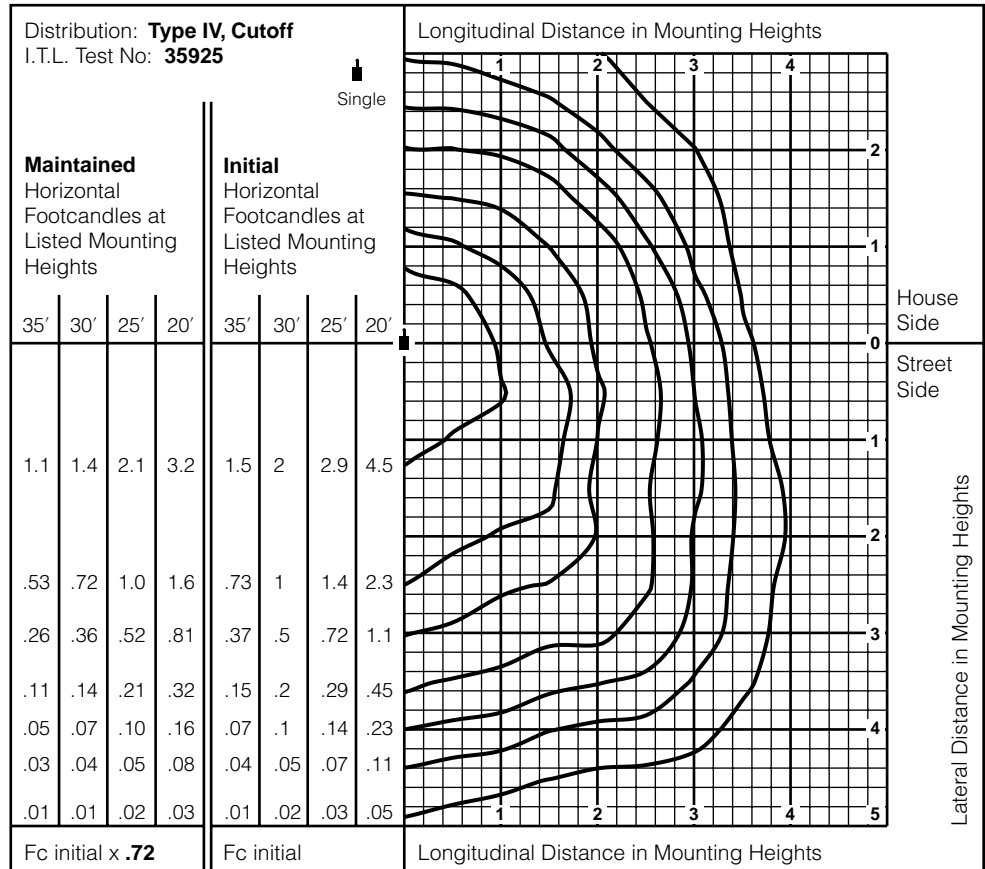

## Type V - Square

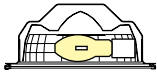
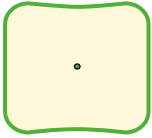

Horizontal Lamp  
Flat Lens  
Cutoff

### 400 Watt Metal Halide

40,000 Initial Horizontal Lumens  
32,000 Mean Horizontal Lumens

REPORT NUMBER: **ITL 35936**  
DISTRIBUTION: **Type V Square**  
REFLECTOR: **Multi-faceted - peened reflector above lamp, multi faceted specular reflector, diffuse former**

#### MAXIMUM PLANE AND CONE PLOTS OF CANDELA

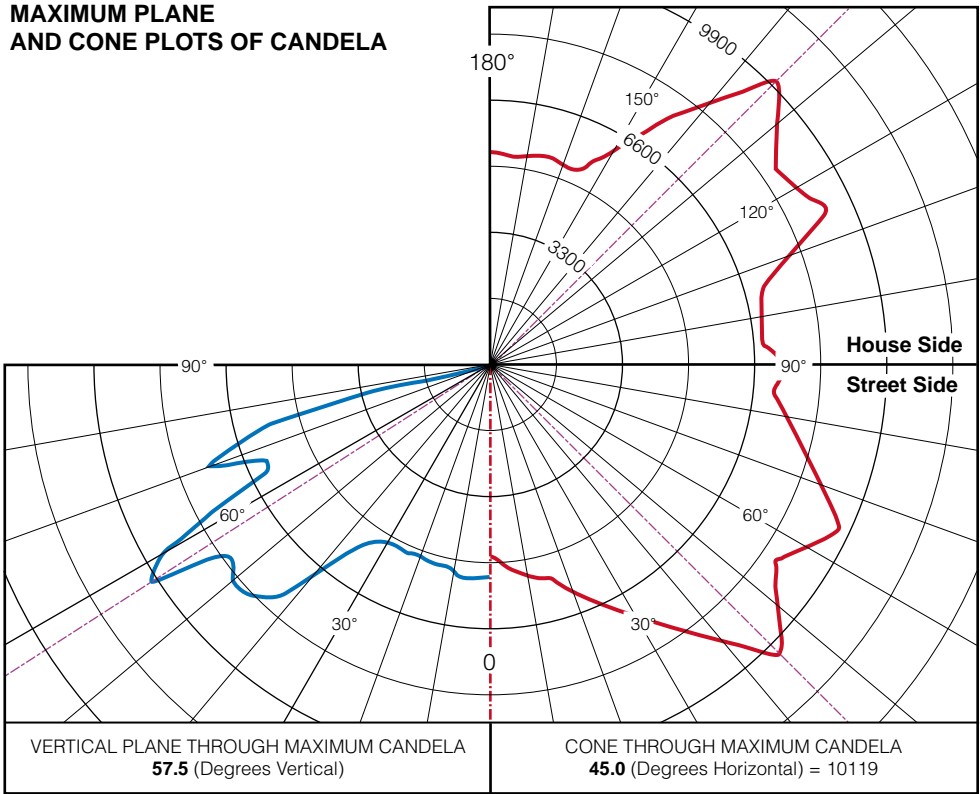

#### ISOFOOTCANDLE PLOT

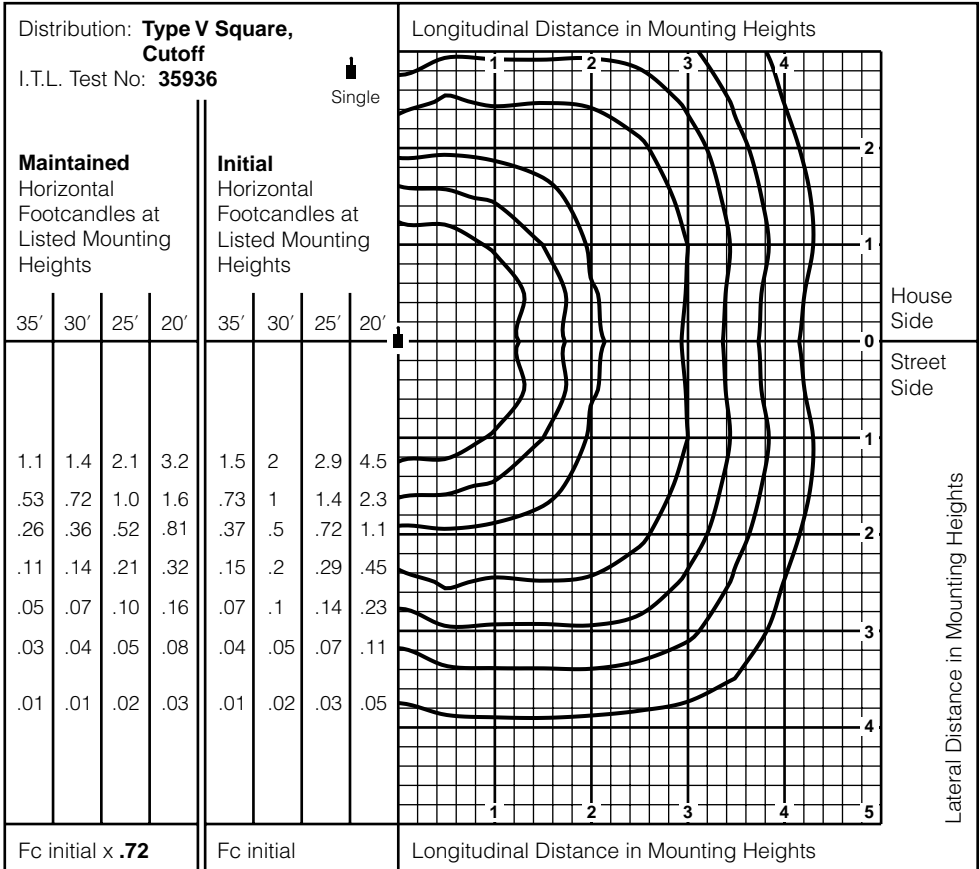

# Horizontal Lamp

## Flat Louvered Shield for Horizontal Lamp with Flat Lens

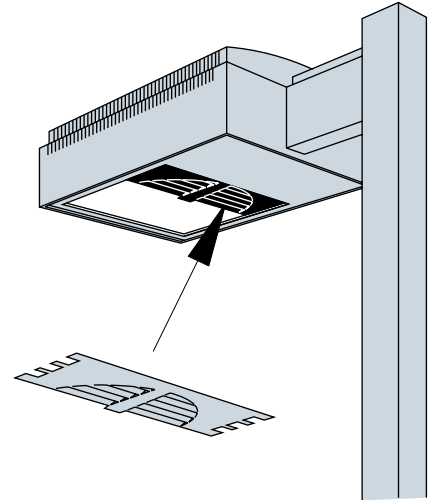
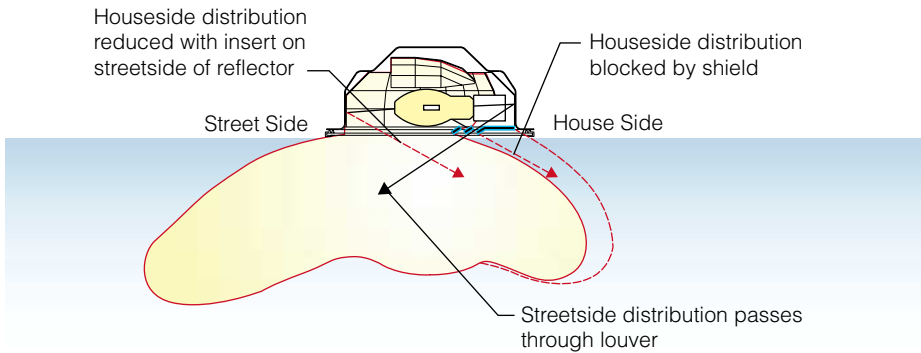

**Houseside Shield:** Stamped aluminum with louvers that pass streetside light and block houseside light. Clear anodized finish. Attaches to lens frame on any of four sides to insure correct orientation with reflector. Black panel added to reflector on the street side to reduce houseside reflection. Use with clear lamps only. Not for use on Type V Square distributions

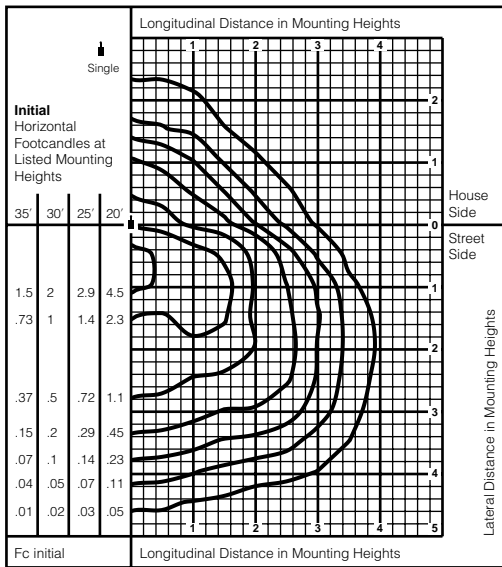

**Horizontal Lamp  
Type IV  
400 Watt  
Metal Halide**

*With  
Flat Lens /  
Houseside  
Shield*

## Formed Shields for Horizontal Lamp with Optional Convex Lens

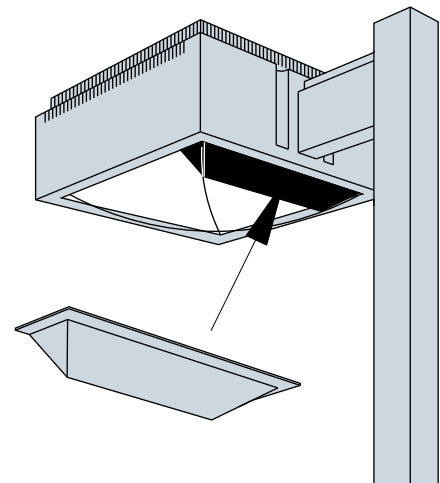
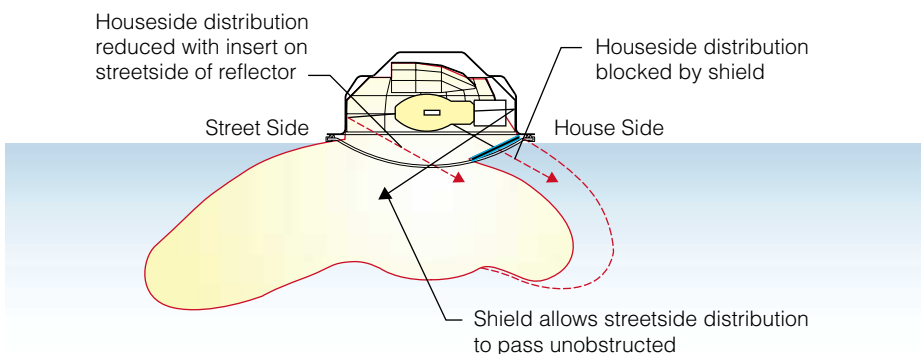

**Houseside Shield:** Stamped aluminum. Clear anodized finish. Attaches to lens frame (or reflector frame) on any of four sides to insure correct orientation with reflector. Black panel added to reflector to reduce houseside reflection. Use with clear lamps only. Not for use on Type V distributions.

# Two-Tier Vertical Lamp

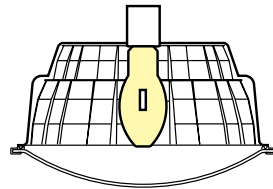

Vertical Lamp  
Convex Lens

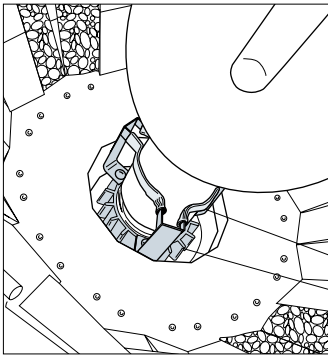

**Two-Tier Vertical Lamp** systems incorporate heat sinks to reduce socket operating temperatures and clamp style lamp stabilizers (400-1000 watt MH and 400 watt HPS lamps only) to protect lamp envelope from vibration failure.

Lamp Vibration Clamp  
Socket Heat Sink



**High Lamp Position**  
Narrow Distribution  
High Intensity

**Low Lamp Position**  
Wide Distribution  
Maximum Spacing

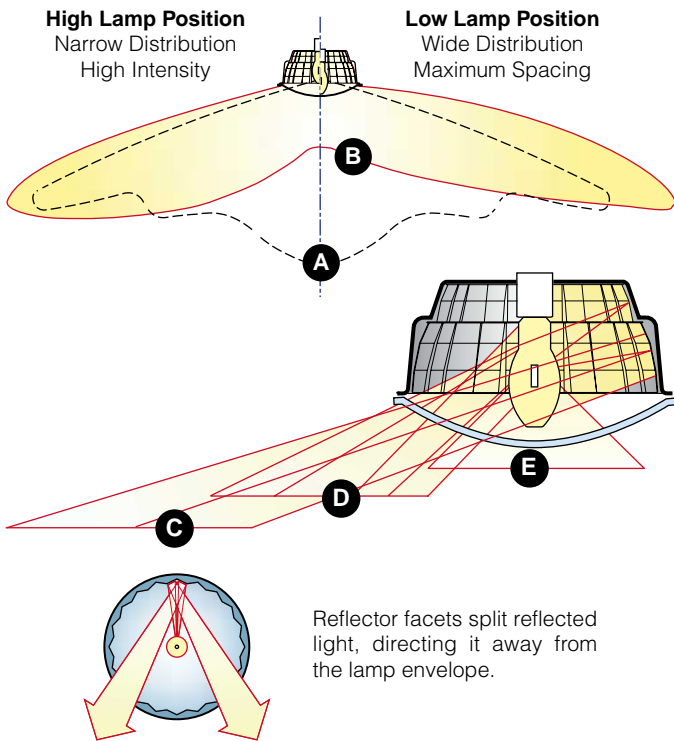

For maximum pole spacing and optimum uniformity over large areas, the two-tier vertical lamp system is ideal. Producing good cutoff with minimal light above 90°, this system is engineered to provide layouts with the fewest luminaires possible. The primary reflector panels are highly specular to achieve precise lamp arc reflections toward the desired areas on the ground.

- A** Typical horizontal lamp “Shoobox luminaires” produce excessive straight-down illumination in relation to side throw. This causes poor uniformity and requires closer pole spacings.
- B** The Kim system has minimal straight-down illumination and substantially increased side throw. This produces superior uniformity and the maximum pole spacing attainable.
- C** High angle distribution is maximized by the vertical lamp orientation, split beam optics, convex lens and specular side panel elements.
- D** Mid range and transition distribution is produced by the natural bare lamp output. Side panel elements are engineered to provide smooth transition from raw lamp output to high angle distribution without dark rings or spots.
- E** Low angle distribution from bare lamp output is adequate. The lamp's natural distribution is well suited to provide minimal under-fixture brightness.

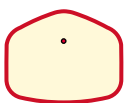

**N3 / W3**  
Asymmetric - Narrow  
Asymmetric - Wide

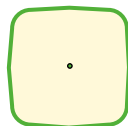

**N5 / W5**  
Symmetric Square - Narrow  
Symmetric Square - Wide

## Socket Position

High and Low socket position is fixed at the factory to assure proper arc tube positioning within the reflector system.

**70 - 1000 Watt MH**  
**70 - 1000 Watt HPS**

# Two-Tier Vertical Lamp

## N3 Asymmetric - Narrow

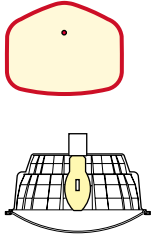

Vertical Lamp  
Convex Lens  
Cutoff

### 400 Watt Metal Halide

40,000 Initial Horizontal Lumens  
32,000 Mean Horizontal Lumens

REPORT NUMBER: **ITL 38902**  
DISTRIBUTION: **Type III - Narrow**  
REFLECTOR: **Multi-faceted - peened reflector above lamp, multi faceted specular reflector, diffuse former**

MAXIMUM PLANE  
AND CONE PLOTS OF CANDELA

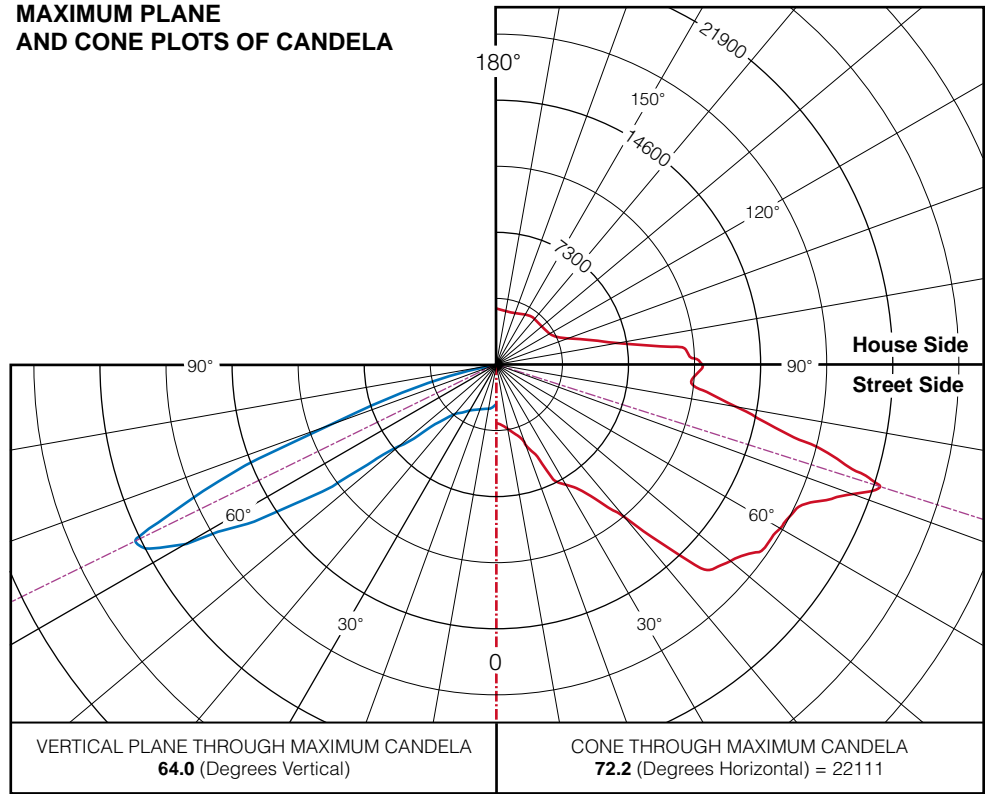

ISOFOOTCANDLE PLOT

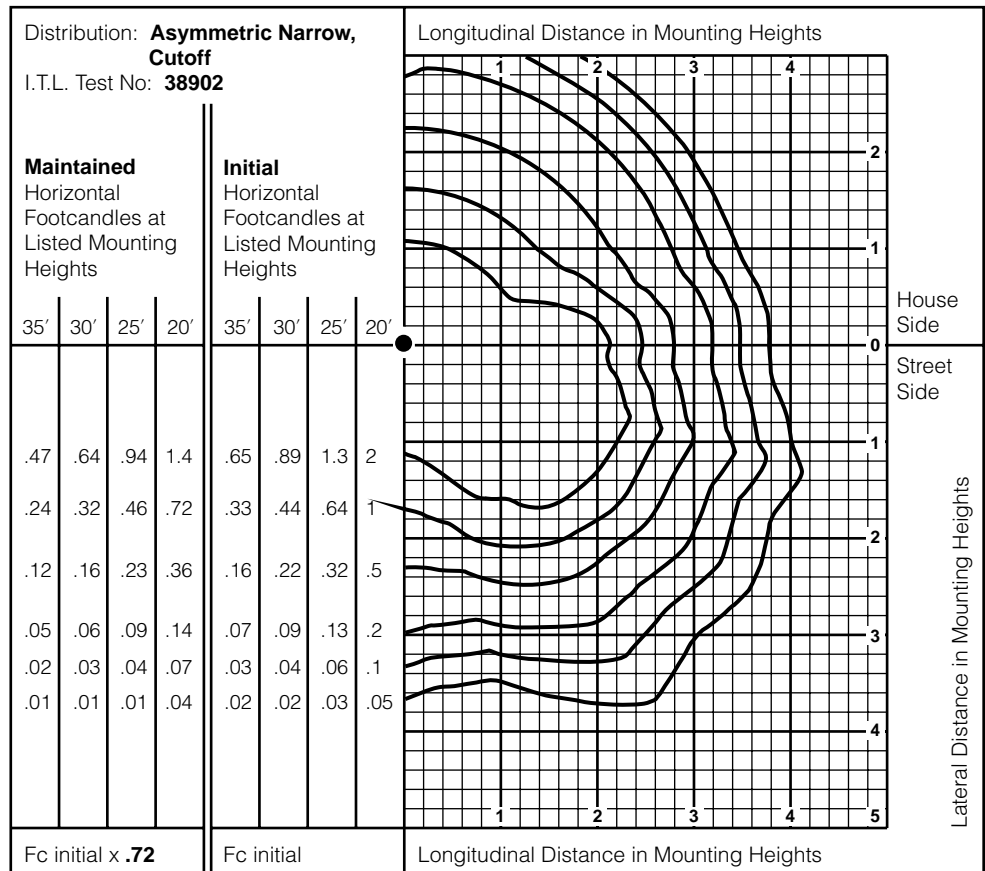

# Two-Tier Vertical Lamp

## W3 Asymmetric - Wide

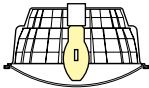
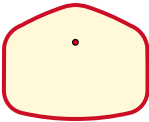

Vertical Lamp  
Convex Lens  
Semi-Cutoff

### 400 Watt Metal Halide

40,000 Initial Horizontal Lumens  
32,000 Mean Horizontal Lumens

REPORT NUMBER: **ITL 38857**  
DISTRIBUTION: **Type III - Wide**  
REFLECTOR: **Multi-faceted - peened reflector above lamp, multi faceted specular reflector, diffuse former**

### MAXIMUM PLANE AND CONE PLOTS OF CANDELA

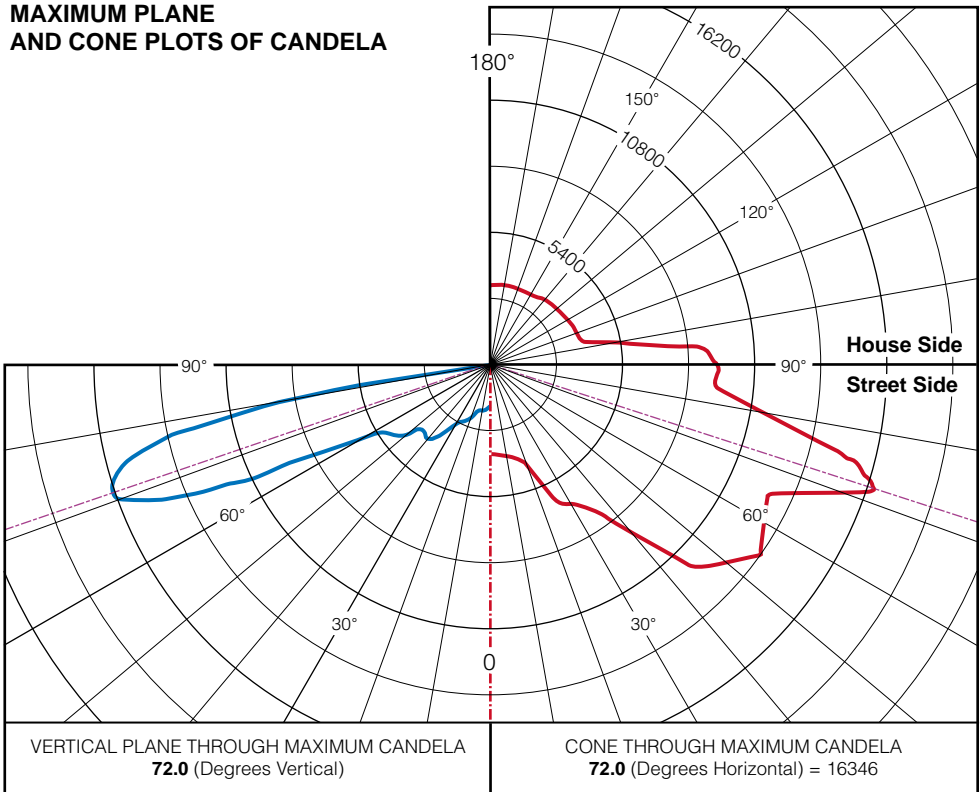

### ISOFOOTCANDLE PLOT

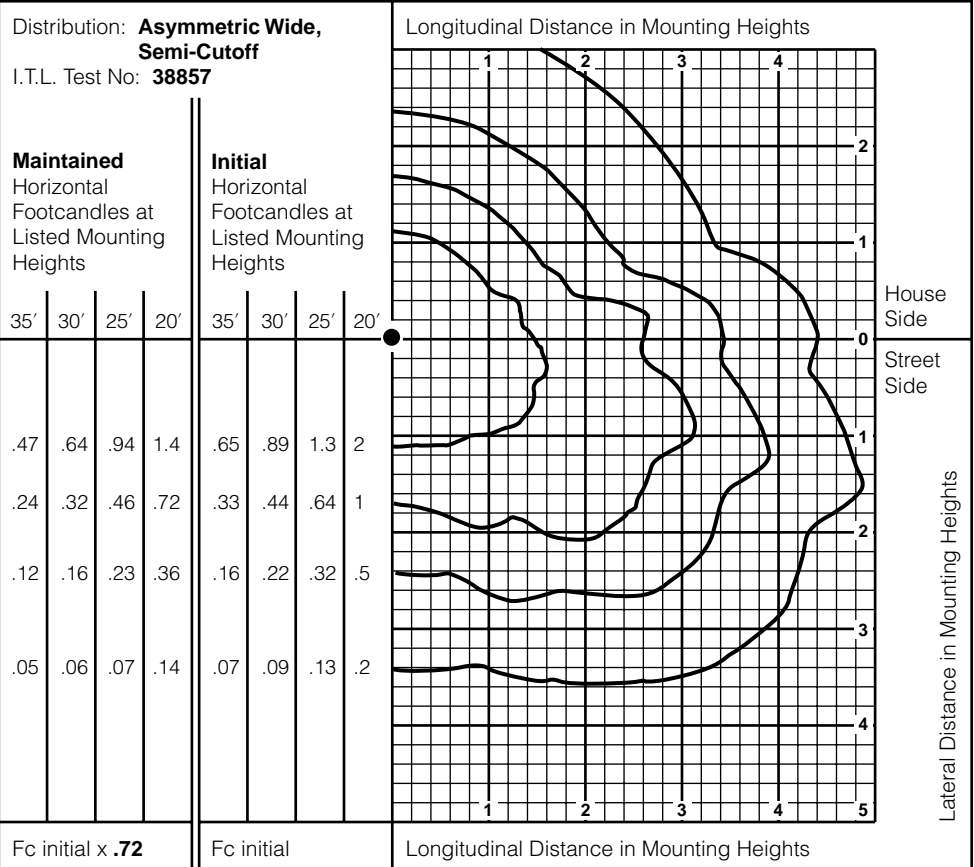

# Two-Tier Vertical Lamp

## N5 Symmetric Square - Narrow

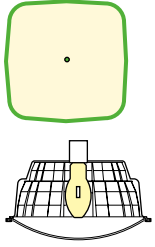

Vertical Lamp  
Convex Lens  
Cutoff

### 400 Watt Metal Halide

40,000 Initial Horizontal Lumens  
32,000 Mean Horizontal Lumens

REPORT NUMBER: **ITL 38895**  
DISTRIBUTION: **Type V - Narrow**  
REFLECTOR: **Multi-faceted - peened reflector above lamp, multi faceted specular reflector, diffuse former**

MAXIMUM PLANE AND CONE PLOTS OF CANDELA

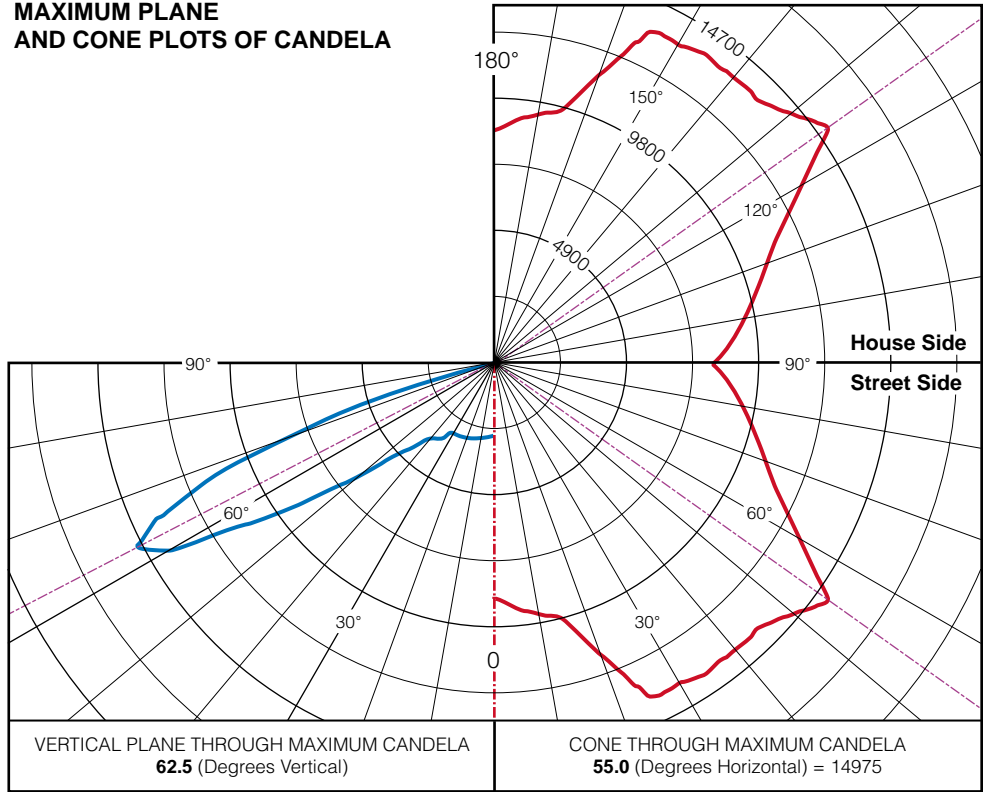

ISOFOOTCANDLE PLOT

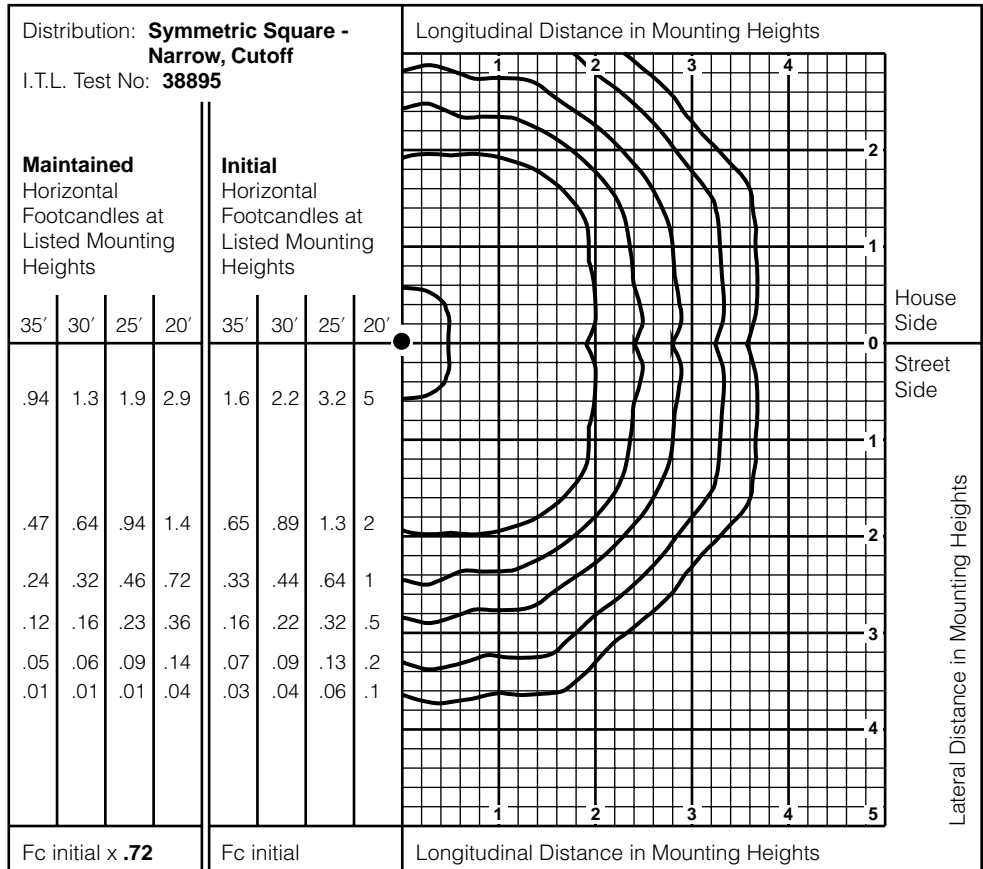

# Two-Tier Vertical Lamp

## W5 Symmetric Square - Wide

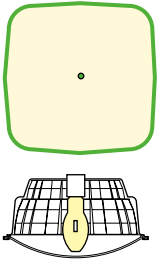

Vertical Lamp  
Convex Lens  
Semi-Cutoff

### 400 Watt Metal Halide

40,000 Initial Horizontal Lumens  
32,000 Mean Horizontal Lumens

REPORT NUMBER: **ITL 38856**  
DISTRIBUTION: **Type V - Wide**  
REFLECTOR: **Multi-faceted - peened reflector above lamp, multi faceted specular reflector, diffuse former**

### MAXIMUM PLANE AND CONE PLOTS OF CANDELA

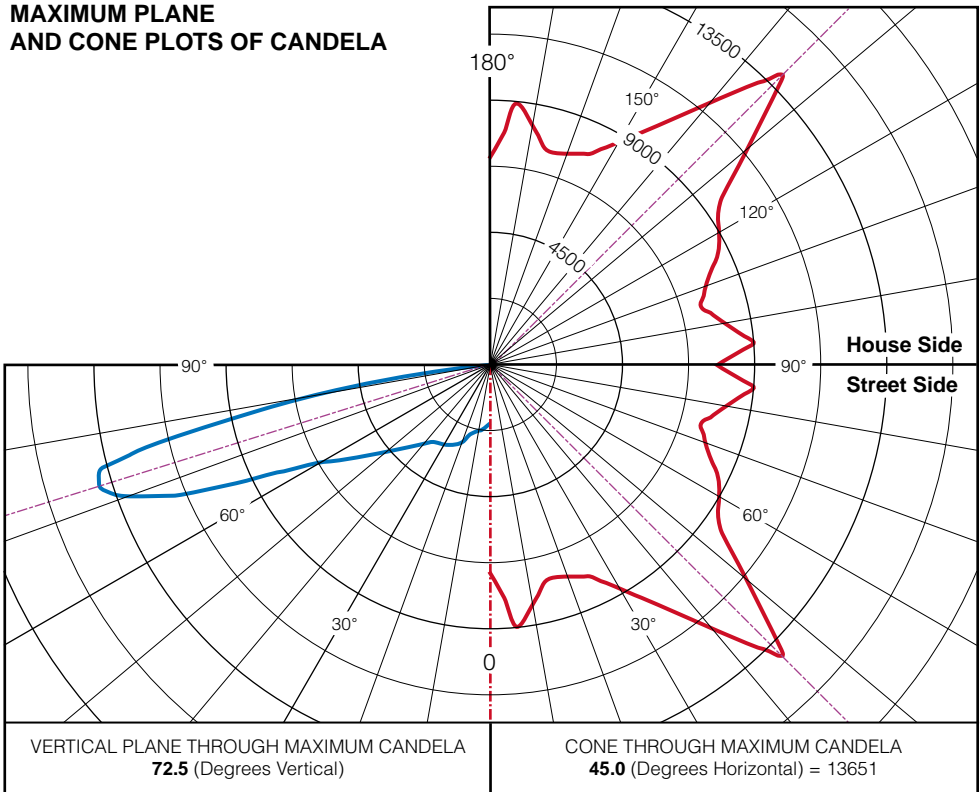

### ISOFOOTCANDLE PLOT

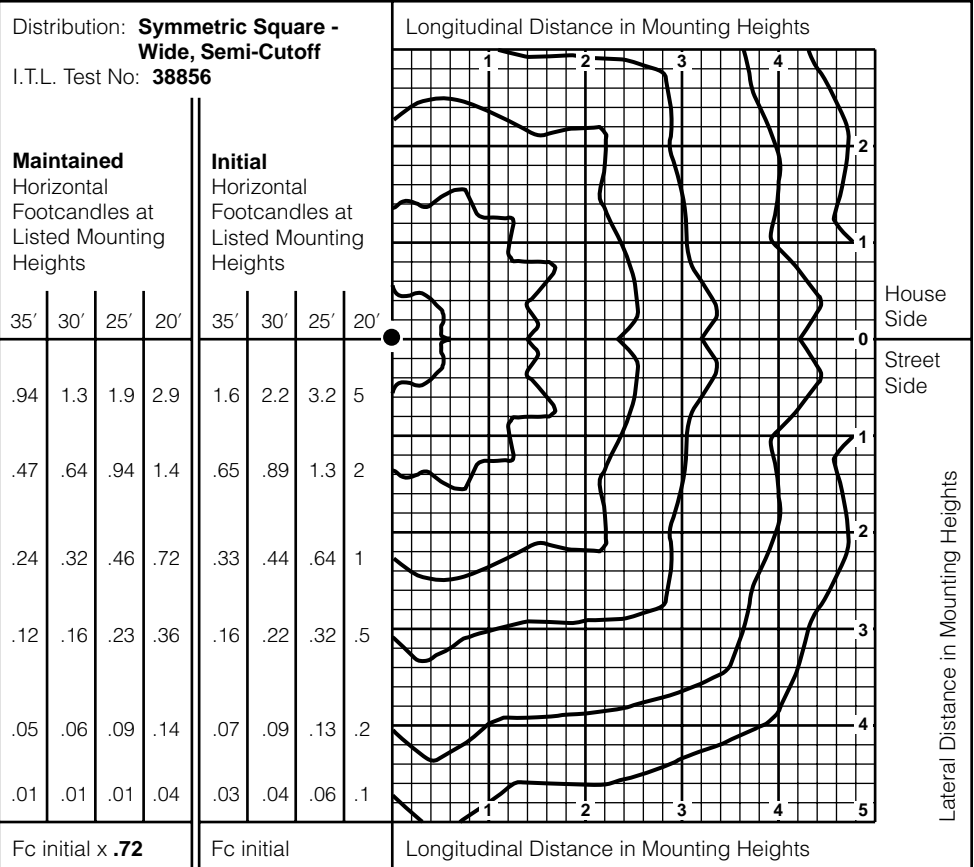

# Two-Tier Vertical Lamp

## Formed Shields for Vertical Lamp - Convex Lens

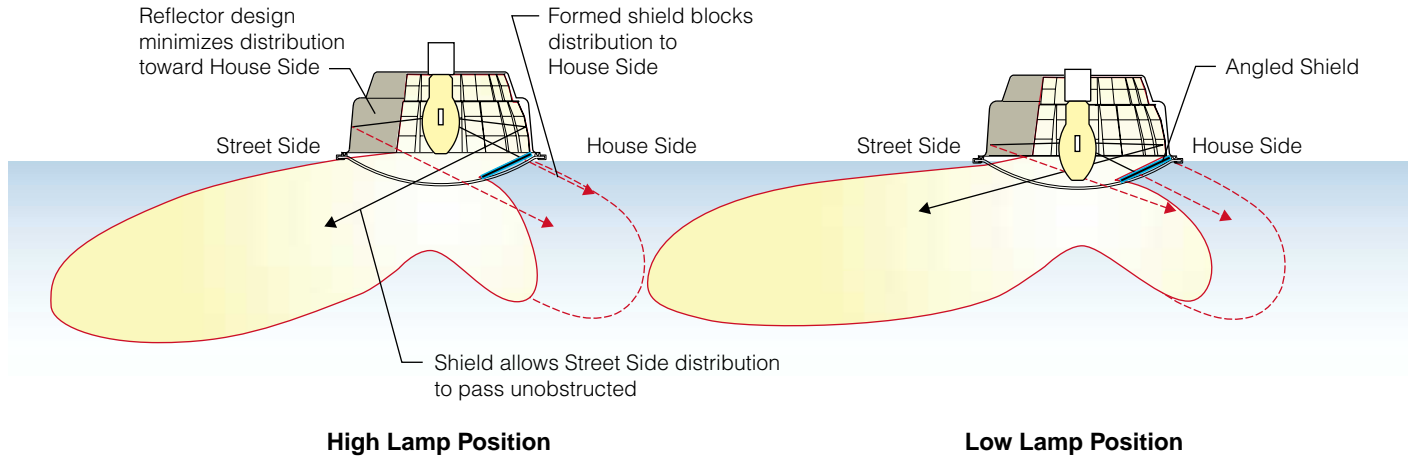

**Houseside Shield:** Spun aluminum. Clear anodized finish. Attaches to reflector frame in correct orientation with reflector. Use with clear lamps only. Not for use on Symmetric distributions.

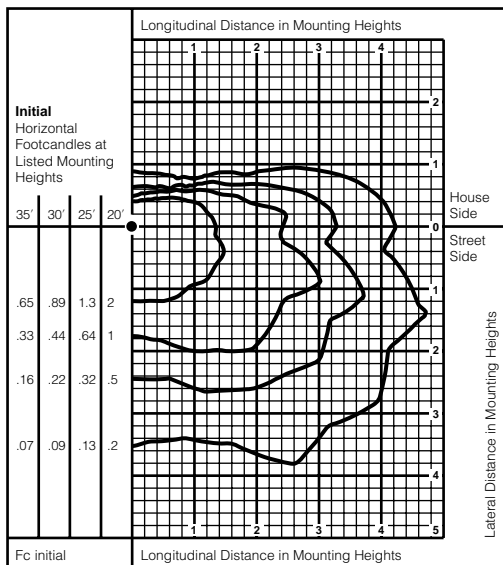
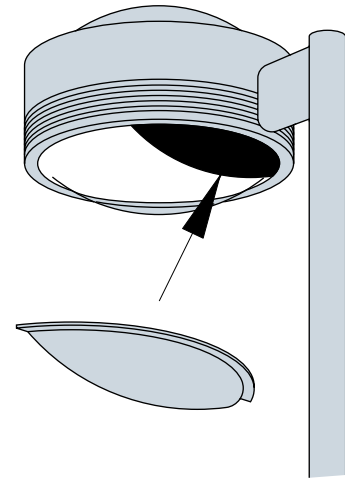

**Vertical Lamp**  
**Asymmetric - Wide**  
**400 Watt**  
**Metal Halide**

*With*  
 Convex Lens /  
 Houseside  
 Shield

ITL Test No.  
 38901

# Single-Tier Vertical Lamp

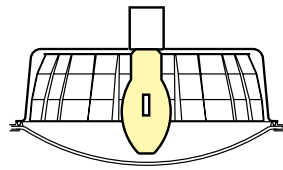
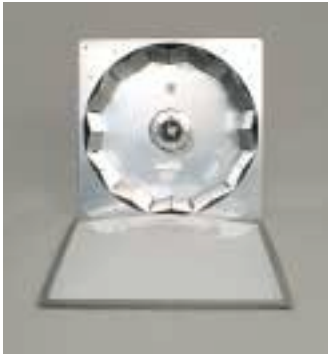

Vertical Lamp  
Convex Lens

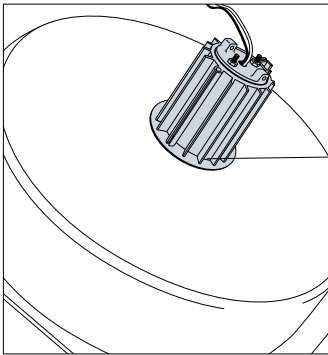

**Single-Tier Vertical Lamp** systems incorporate heat sinks to reduce socket operating temperatures.

Socket Heat Sink



Comparative  
Horizontal Lamp  
distribution

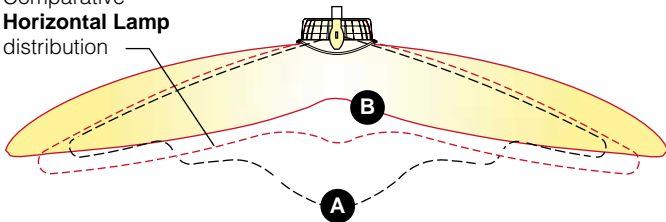

Comparative  
Horizontal Lamp  
distribution

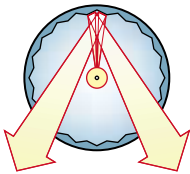
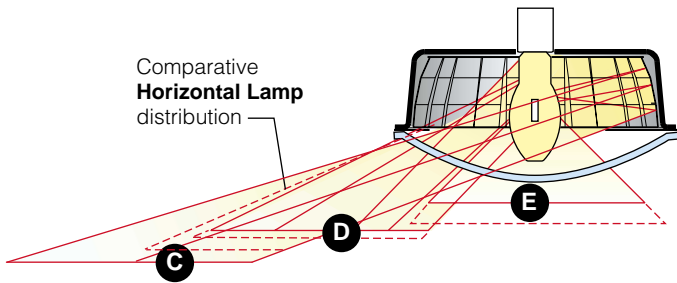

Reflector facets split reflected light, directing it away from the lamp envelope.

**For maximum pole spacing and optimal uniformity over large areas, in compact luminaire enclosures, the single-tier vertical lamp system is ideal.** Producing good cutoff with minimal light above 90°, this system is engineered to provide layouts with the fewest luminaires possible. The primary reflector panels are highly specular to achieve precise lamp arc reflections toward the desired areas on the ground.

- A** Typical horizontal lamp “Shoebbox luminaires” produce excessive straight-down illumination in relation to side throw. This causes poor uniformity and requires closer pole spacings.
- B** The Kim system has minimal straight-down illumination and substantially increased side throw. This produces superior uniformity and the maximum pole spacing attainable.
- C** High angle distribution is maximized by the vertical lamp orientation, split beam optics, convex lens and specular side panel elements.
- D** Mid range and transition distribution is produced by the natural bare lamp output. Side panel elements are engineered to provide smooth transition from raw lamp output to high angle distribution without dark rings or spots.
- E** Low angle distribution from bare lamp output is adequate. The lamp’s natural distribution is well suited to provide minimal under-fixture brightness.

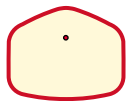

F3  
Asymmetric - Wide

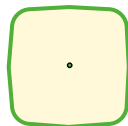

F5  
Symmetric Square - Wide

**70 - 400 Watt MH**  
**70 - 400 Watt HPS**

# Single-Tier Vertical Lamp

## F3 Asymmetric

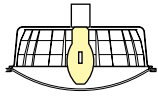
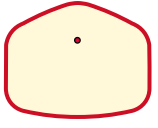

Vertical Lamp  
Convex Lens  
Semi-Cutoff

### 400 Watt Metal Halide

40,000 Initial Horizontal Lumens  
32,000 Mean Horizontal Lumens

REPORT NUMBER: **ITL 44887**  
DISTRIBUTION: **Type III - Wide**  
REFLECTOR: **Multi-faceted - peened reflector above lamp, multi faceted specular reflector, diffuse former**

**MAXIMUM PLANE  
AND CONE PLOTS OF CANDELA**

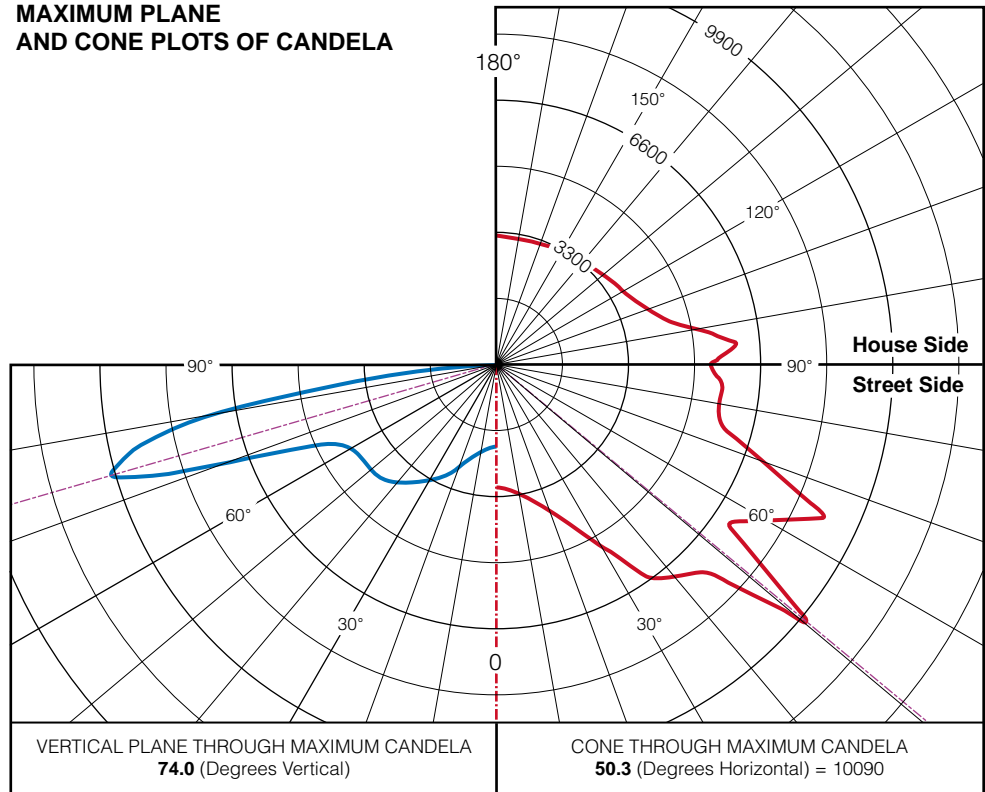

**ISOFOOTCANDLE PLOT**

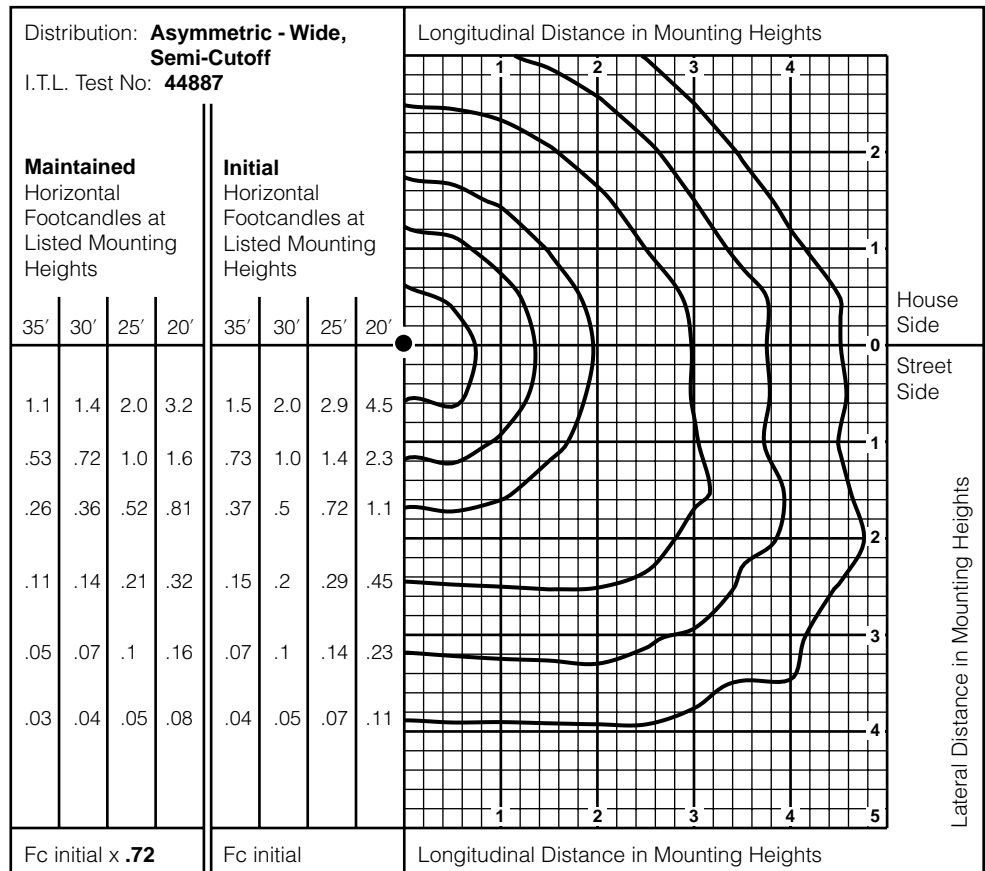

## F5 Symmetric Square

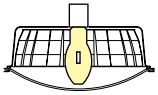
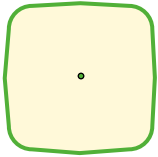

Vertical Lamp  
Convex Lens  
Semi-Cutoff

### 400 Watt Metal Halide

40,000 Initial Horizontal Lumens  
32,000 Mean Horizontal Lumens

REPORT NUMBER: **ITL 44894**  
DISTRIBUTION: **Type V - Wide**  
REFLECTOR: **Multi-faceted - peened reflector above lamp, multi faceted specular reflector, diffuse former**

#### MAXIMUM PLANE AND CONE PLOTS OF CANDELA

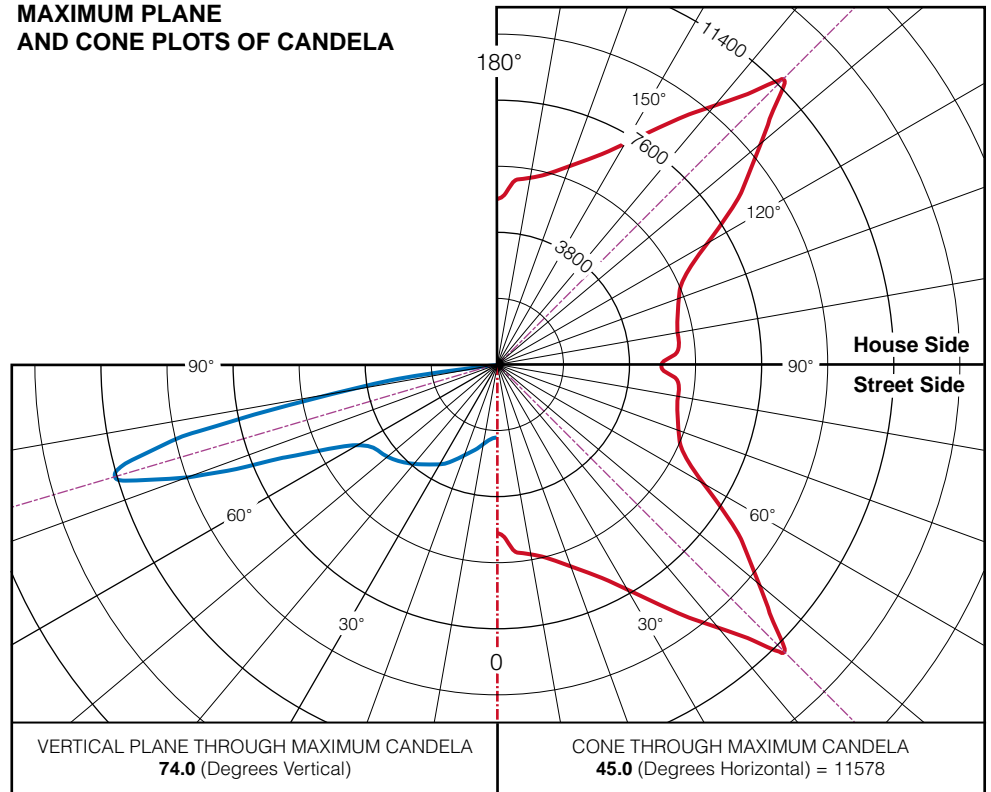

VERTICAL PLANE THROUGH MAXIMUM CANDELA  
74.0 (Degrees Vertical)

CONE THROUGH MAXIMUM CANDELA  
45.0 (Degrees Horizontal) = 11578

#### ISOFOOTCANDLE PLOT

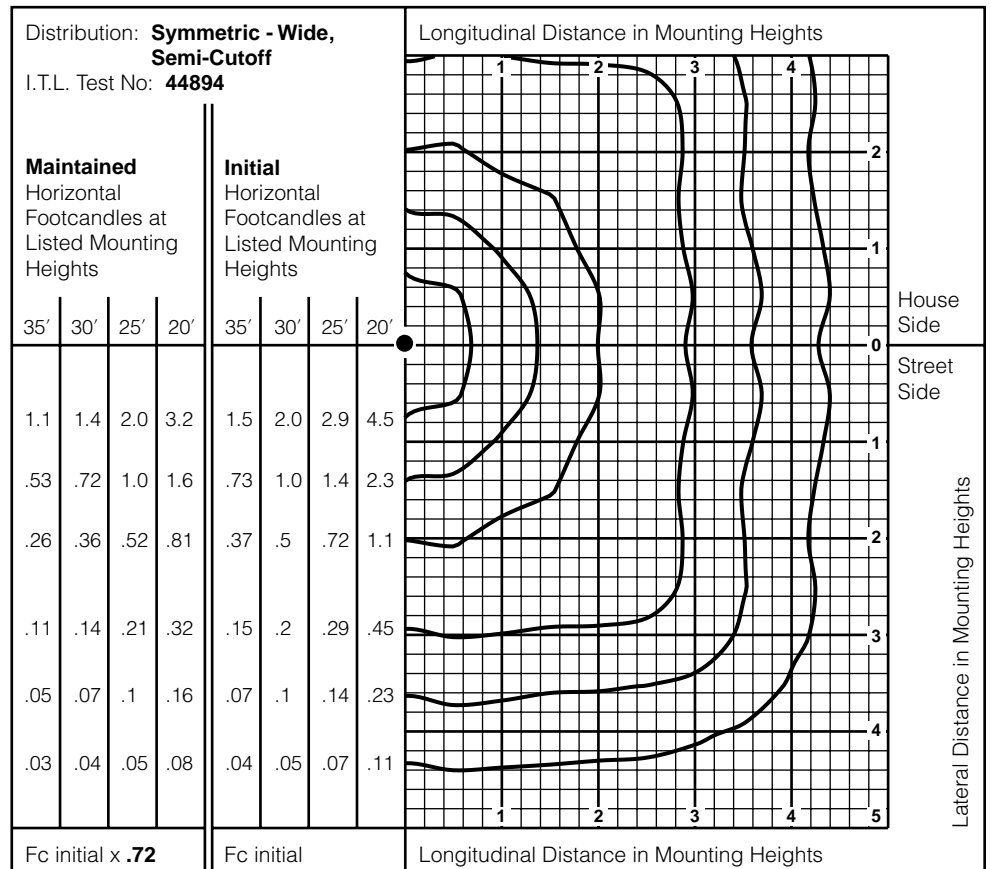

# Single-Tier Vertical Lamp

## Formed Shields for Vertical Lamp - Convex Lens

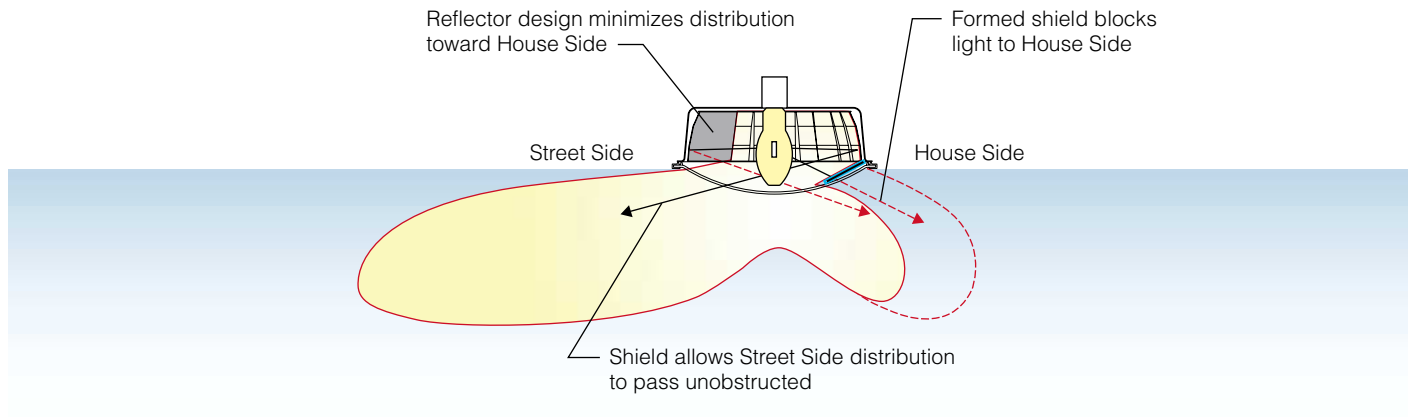

**Houseside Shield:** Spun aluminum. Clear anodized finish. Attaches to reflector frame in correct orientation with reflector. Use with clear lamps only. Not for use on Symmetric distribution.

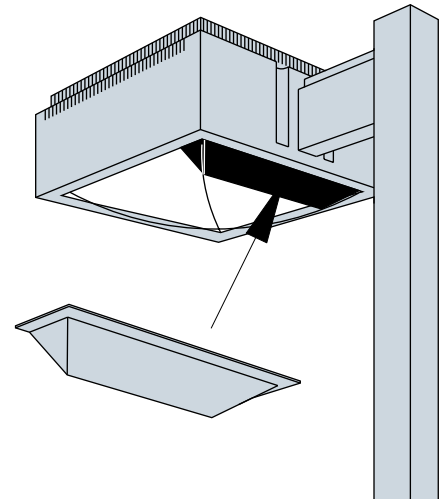

# Specification Data and Applications Assistance

## Electronic Information Available



### Applications Assistance

Kim Lighting utilizes the latest computer technology and software to provide specifiers with reliable evaluations of lighting system performance.

Kim can analyze a proposed luminaire layout or provide recommendations based on performance criteria.

Hard copies of plans can be sent directly to the Kim Applications Department via fax, express or regular mail. Any .dwg or .dxf file can be transmitted via modem or email ([kimapps@kimlighting.com](mailto:kimapps@kimlighting.com)), or placed on diskette, CD ROM or Zip disk, and forwarded to Kim Lighting c/o Kim Apps.



### Specification Information

To obtain a copy of the complete full color, 640 page KIM product binder, contact your local Kim Lighting representative.

Specification information in electronic format is available on CD ROM as well as on the Internet. Visit [www.kimlighting.com](http://www.kimlighting.com) for free access to all Kim specification data sheets in .pdf format for viewing with Adobe Acrobat Reader. For convenience Acrobat Reader is included on the CD ROM as well as on the web site for immediate download.



### Photometric Files

Kim photometric files are available free in both electronic and hard copy format.

Electronic photometric files include .pdf file format pages for printing and .ies files for use in lighting calculation software. The complete .ies / .pdf library is available on CD ROM and on the internet at [www.kimlighting.com](http://www.kimlighting.com).

### Footnotes:

1. ITL Reports using IES guidelines consider any crossing of the identified boundaries as definition of overall Type, regardless of its impact or significance to applied performance. Classifications indicated do not consider minor deviations in classification of Type shown.
2. The "Very Short Range" identification is not an IES standard definition, but is used by ITL to identify distributions with ranges inside the 1.0 MH allowed in the "Short Range" definition established.
3. Information shown is for illustrative purposes only and does not represent a specific luminaire's performance.
4. Definition is extracted from IES Lighting Handbook, 8th edition.
5. Definition has not been identified by the IES at this time. Definition shown is based on Kim Lighting research and development efforts and engineering of optical systems to improve applied performance.
6. Distribution may be classified by ITL, using IES standard practices, as a Type IV distribution, due to a small portion of the 50% isocandela trace falling beyond the 2.75 MH line. This aberration in classification methodology conflicts with luminaire applied performance. Classification indicated more accurately represents actual luminaire usage.