

LED Luminaires and Light Distribution: A Technology for Uniformity, Control, & Upgradeability

Kim Lighting, City of Industry, CA – 10/2010

Abstract

This technical paper describes a novel technology for providing uniform illumination from light-emitting diode (LED) light sources in architectural outdoor/site applications. Rather than manipulate the light distribution from a flat array of diodes by means of refractors (commonly know as light bars), this approach aims each diode individually using a patent-pending MicroEmitter.¹ The benefits of this technique include glare control, uniformity of illumination, elimination of excessive and unnecessary light concentration beneath the luminaire (“nadir dump”), elimination of light pollution through backlight or up-light, exceptional thermal management, and the ability to upgrade existing luminaires. This technology also addresses a common and often unintended practice that leads to wasted light and energy in site/street applications; designing for unnecessarily high *average* illumination levels. The MicroEmitter is shown to assist in achieving the targeted minimum illumination levels with exceptional Max:Min uniformity, thereby improving the end-user experience while reducing energy use and carbon footprint.

1. Background

LEDs, the key component in solid-state lighting systems, have increased greatly in performance over the last several years. Lighting designers, engineers, and architects are increasingly capitalizing on the many benefits of this relatively new architectural light source in their site lighting designs.

Unlike the single, centralized point source characteristic of traditional lamps, LED diodes function as multiple points of lower-output, omni-directional light. Herein lies the central challenge and opportunity of LED luminaire design.

Developers of LED luminaires have sought more effective ways to distribute the light output of diode arrays than were characterized by early adopters. The technology described in this white paper maximizes the benefits that LED directionality can provide through individual diode control by reflectors and aiming of each diode grouping.

2. The MicroEmitter

The MicroEmitter module is designed to produce high task efficacy by directing diode output to precisely defined task areas. The MicroEmitter consists of a three-diode LED board, an aluminum heat sink, and an EmitterReflector that focuses diode output and controls stray light.

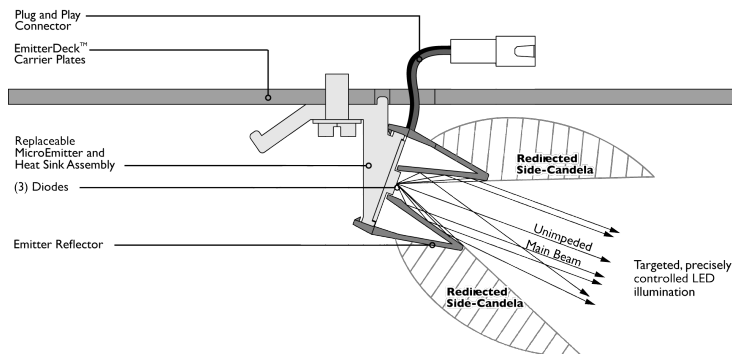

¹ MicroEmitter™ is a patent-pending device trademarked and owned by Kim Lighting, City of Industry, CA.

The optical surface of the EmitterReflector is precisely contoured such that each MicroEmitter functions much like a miniature floodlight luminaire. Each MicroEmitter is carefully aimed to its respective zone to produce uniform, high task-efficacy illumination in any of a variety of IES distribution patterns. Individual aiming of MicroEmitters provides several significant benefits:

- **Lumens are directed to the target task only:** Unlike conventional HID Reflector Systems, MicroEmitters are aimed only toward the target region. The typical distribution of a horizontal HID lamp directs a high percentage of lumens downward toward nadir.
- **Backlight is minimized:** MicroEmitter optics minimize wasteful and neighbor-unfriendly backlight pollution through careful aiming and shielding. Costly, inconvenient, and unsightly “house side shield” accessories are unnecessary to provide backlight control. Backlight control is easily accomplished by directing all light forward.
- **Uniformity is significantly improved:** MicroEmitters are aimed at critical angles to direct the main beam intensity toward distant points within the targeted task area, thereby boosting minimum illumination levels. Maximum illumination levels are controlled because no MicroEmitters are aimed straight down. The required luminous intensity is provided directly beneath the luminaire (where close proximity produces higher footcandle levels) through utilization of Diode spill light alone. By boosting minimum illumination and limiting maximum illumination in this manner, MicroEmitter luminaires are capable of achieving exceptional uniformity ratios of 3:1 and better for many applications, while maintaining broad pole spacing of as far as 5x the mounting height.

Each MicroEmitter is individually aimed and arranged in an array called an EmitterDeck™. Each individual MicroEmitter is connected to the EmitterDeck wiring harness via its own wiring quick-connect and can be purchased as a replacement part for easy replacement in minutes in the unlikely event of a diode failure. The EmitterDeck itself also features a master quick-connect. This provides modular connection to the electrical output of the electronic driver, allowing EmitterDecks to be easily replaced for future upgrade as LED technology advances. A unique thermal monitoring and control system is integrated into the EmitterDeck and the luminaire gear compartment to preserve diode life in high ambient temperature environments.

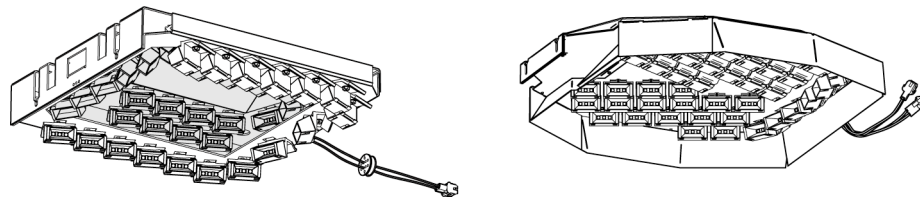

In contrast to a MicroEmitter system, most other typical outdoor LED luminaires make use of flat circuit boards aimed directly downward and covered with refractive caps. All LEDs are located at the lower surface of the luminaire and are exposed to the viewer at all viewing angles, thereby producing excessive glare. Since the diodes and refractors are aimed straight down, the footcandle level directly beneath the luminaire is higher than the design minimum footcandle target, resulting in wasteful “nadir dump” and poor uniformity. Because refractors have limited capability to control light scattering, LED Light Bar luminaires are not as effective in limiting spill light behind the pole. Such luminaires also feature limited or no modularity, making replacement of the LED light engine for service or upgrade impractical or impossible.

Most LED luminaires, whether MicroEmitter or Light Bar based, wire the diodes in series. Diode failure, while very rare, is almost always in a “closed circuit” failure mode. Accordingly, the remaining diodes in the luminaire continue to operate despite the failure of an individual diode. Although MicroEmitter systems and Light Bar systems are alike in this regard, the modularity of the MicroEmitter allows for the rare diode failure to be addressed through simple field replacement of the affected MicroEmitter. This is not possible in most Light Bar luminaires. Further, the diversity of individual diode aiming in MicroEmitter luminaires makes a failed diode less visually obvious than in Light Bar refractive optics, where a failed diode is obvious and objectionable.

3. Light Distribution Patterns

MicroEmitter technology opens new possibilities for light distribution. MicroEmitter precision provides the lighting designer with a full palette of distribution patterns to light diverse site geometries without compromise. Because MicroEmitters can be factory aimed within the EmitterDeck with great flexibility, unique distribution patterns beyond Types I, II, III, IV and V are possible on a custom basis. Examples of these new distribution possibilities include one-way left and one-way right distributions that can be an effective solution for one-way vehicular traffic, intersection, parking lot corner, and other unique applications.

Most MicroEmitter optical distribution types make use of 70° peak intensity aiming. To achieve the same horizontal footcandles throughout a given space, the peak intensity needs to be ten times the intensity at nadir (10:1). The MicroEmitter system achieves an 8:1 peak intensity ratio. This approach results in superb uniformity and less wasteful light at nadir. The resulting uniformity is far superior to most traditional horizontal HID and typical refractive Light Bar luminaires, which have the peak intensity ratio of 5:1. The modular nature of the MicroEmitter also allows luminaire types like Parking Garage luminaires provided in a narrow optic featuring a peak intensity angle of 57.5°. This concentrated narrow intensity can be an effective solution for tight task areas or regions where increased light levels are required.

4. Glare Control

Individual aiming of each MicroEmitter assures that fewer than 50% of the LEDs are visible from any viewing position. As a result, substantially fewer equivalent watts of source output are projected into the viewer's eyes than that of LED Light Bar luminaires or traditional HID luminaires (ex: 150W Metal Halide arc tube).

5. Uniformity

Luminaires incorporating MicroEmitter technology are capable of lighting a task area with exceptional uniformity of illumination. That uniformity is achieved not only by boosting the minimum illumination levels located at great distance from the source, but also by reducing maximum footcandle levels at a short distance from the source (nadir dump).

6. Luminaire Efficacy, Task Efficacy, and Energy Efficiency

To date, evaluation of a luminaire's energy efficiency often centers on *luminaire efficacy*.

$$\text{Luminaire Efficacy} = \frac{\text{Lumens Exiting the Luminaire}}{\text{Luminaire Input Wattage}}$$

Today, luminaire efficacy is increasingly understood to provide an incomplete and often distorted view of a luminaire's true energy efficiency. The problem lies in the numerator. Luminaire Efficacy counts *all* lumens exiting the luminaire, regardless of their distribution. All lumens are credited, even those producing excessive maximum illumination beneath the luminaire ("nadir dump"), sky glow (poor cutoff), and backlight pollution. As a result, a poorly designed luminaire can exhibit high luminaire efficacy even though the *useable lumens* it delivers to the target task are much lower.

Although the optical mechanisms of the MicroEmitter reduce the overall *luminaire efficacy* somewhat, MicroEmitter luminaires light a task area more efficaciously than a luminaire with a higher luminaire efficacy. This is because the exceptional uniformity and light trespass control of the MicroEmitter luminaire is capable of producing a higher *task efficacy* (lumens delivered to the *task* per luminaire watt consumed). The MicroEmitter luminaire:

- Illuminates only the **intended task**.
- Restricts **backlight**, also known as light pollution.
- Provides **uniform distribution** by eliminating “nadir dump” of excessive and wasteful lumens directly beneath the luminaire.
- Reduces **glare**, another form of unneeded illumination.

These traits of MicroEmitter luminaire performance also result in superior quality of light and increase viewer comfort and security.

The inadequacies of *luminaire efficacy* calls into question reliance on that metric in the evaluation of a luminaire’s energy efficiency. The Illuminating Engineering Society of North America (IESNA) and the US Department of Energy (DOE) have studied this for outdoor lighting design. In particular, the DOE is reviewing its ENERGY STAR requirements for outdoor/area SSL luminaires in ongoing consideration of a new metric called “fitted-target efficacy,” or FTE, which differentiates useful lumens from those that cause glare, wasted light, and/or light trespass. While FTE has been shown to be an effective measure of luminaire energy performance, DOE has not yet incorporated the measure into its ENERGY STAR program. Below is an example of the current FTE Calculator.

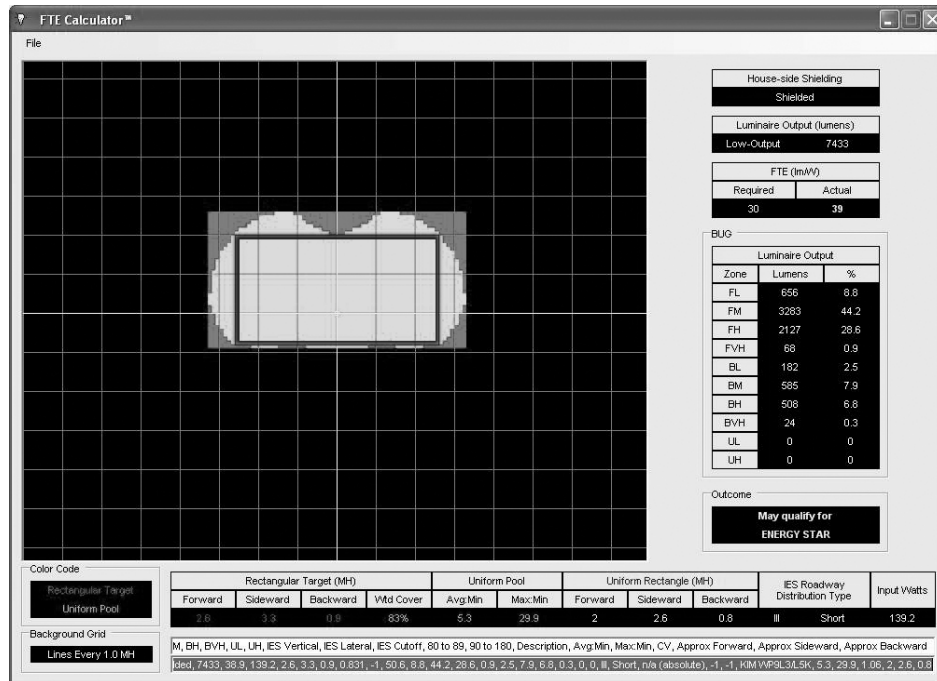

7. Focus on Minimum Footcandles and Uniformity, Not Average fc.

As previously discussed, MicroEmitter luminaires are capable of producing exceptionally low Max:Min uniformity levels. As the ratio of the maximum and minimum illumination levels within a target area is reduced, so too is the *average* illumination level. This necessitates a change in thinking with regard to the evaluation of the illumination levels produced by various outdoor luminaires.

Unlike many indoor applications, most outdoor area/site/street applications are designed to meet application criterion of the required *minimum illumination level* while maintaining a maximum allowable *max/min uniformity level*. A parking lot, for example, might commonly be required to achieve 1 fc minimum with a max/min uniformity ratio of 10:1 or less. *Nowhere is average illumination level* prescribed, nor should it be. This is because, unlike most indoor applications, outdoor environments:

- a) Are designed to provide safety, security, and visibility at the worst case (minimum) illumination level.
- b) Safety and security improves with uniformity (less difference between maximum and minimum illumination levels).

Because the exceptional uniformity of a MicroEmitter luminaire (often 3:1 or better) also results in a lower *average* illumination level, it is tempting to think that a MicroEmitter luminaire produces less light than a conventional luminaire when average illumination levels are inappropriately used as the evaluation criterion. Figure 1 illustrates an example of MicroEmitter luminaire vs. a typical HID (250PMH) luminaire. In both cases, the site is illuminated to the required application criterion of 1 fc minimum with a 10:1 max/min uniformity or better. As the data shows, however, the MicroEmitter luminaire A provides far superior uniformity. The fact that the *average* illumination level of luminaire B is higher merely underscores its inferiority in that it provides a wastefully higher average illumination level than is prescribed in the minimum footcandle requirement.

Figure 1

Luminaire A - MicroEmitter™ LED

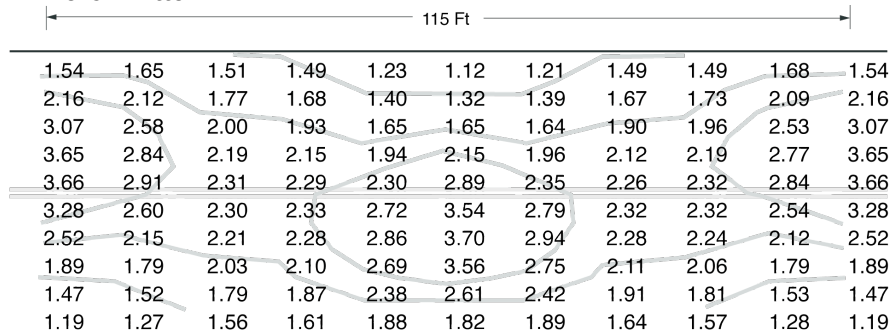

Luminaire B – Pulse Start Metal Halide

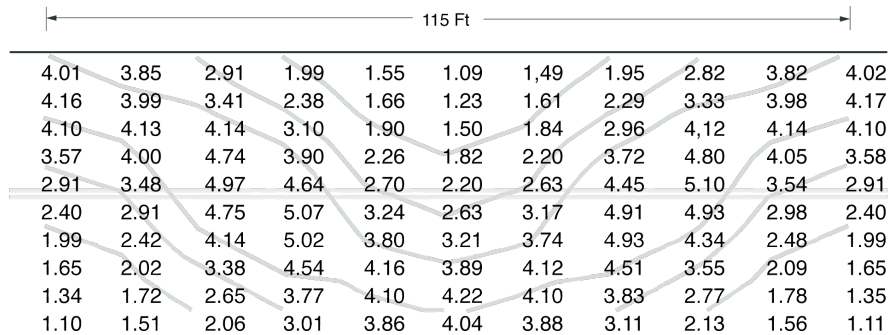

	Input Watts	Avg. FC	Max. FC	Min. FC	Max. to Min.
Luminaire A – MicroEmitter LED	140	2.08	3.70	1.01	3.66:1
Luminaire B - Pulse Start Metal Halide	291	3.06	5.07	0.99	5.12:1

Criteria: Type III distribution, 25' mounting height, street width is 40', spacing is 115'. Luminaires are staggered on each side of the street.

“Bright nadir dump deceives the human eyes such that dim areas appear dimmer. When the human eye adjusts to more uniformly illuminated environments, dim areas appear brighter, resulting in the perception of a safer and more secure environment.”

- Tom Lueken, Product Manager, Kim Lighting

8. Controlling Backlight, Uplight and Glare (BUG Ratings)

The IES has also developed a system for comparing outdoor luminaires in terms of controlling *backlight*, *uplight*, and *glare* – three types of waste illumination. This system is commonly referred to as the “BUG” system.

Backlight refers to light directed opposite the target area, which may create light trespass. Backlight is commonly behind the luminaire.

Uplight is illumination directed above the horizontal plane of the luminaire (90°), which causes artificial sky glow.

Glare is the amount of light from the luminaire emitted in directions or at angles that cause glare, which can be annoying or visually disabling.

BUG values are now published by many luminaire manufacturers to illustrate luminous control capabilities, thereby providing the designer with an excellent comparative tool by which various luminaires can be evaluated. The values are calculated based on the diagram in Figure 2. The B (backlight) rating describes the amount of light in the BL, BM, BH and BVH zones. Upper hemisphere uplight (UH) is mostly energy waste, while lower uplight angles (UL) are more heavily weighted in the BUG and FTE calculation. Last, the G rating evaluates frontlight in the FH, FVH, BH and BVH zones.

Figure 2

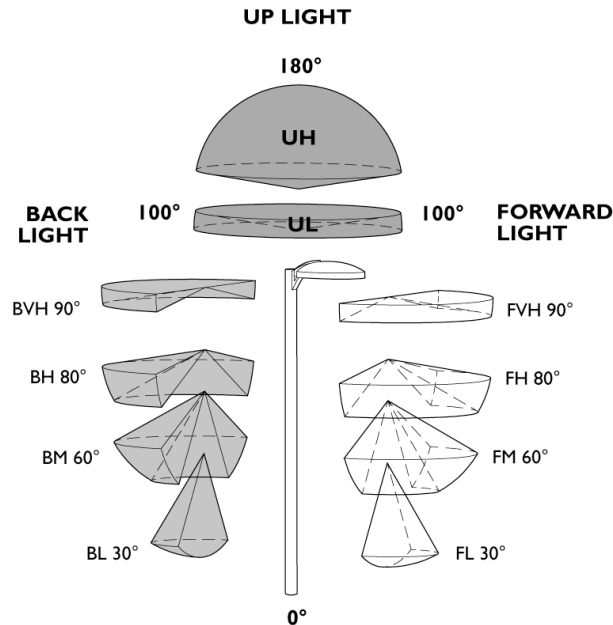

MicroEmitter luminaires are capable of backlight elimination without the need for inefficient accessory house-side shields. Backlight is eliminated simply by directing the MicroEmitters toward task zones only, and carefully controlling spill light to avoid its distribution behind on the house side of the luminaire. By eliminating backlight, all consumed power contributes to illuminating the intended task, waste is reduced, and neighboring sites are not inconvenienced by light trespass.

9. Thermal Management

Thermal management is a critical aspect of LED luminaire design. Although LEDs produce a cool beam, the diode produces considerable heat on the board itself. Because diode life is largely a function of the diode junction temperature, heat must be carefully limited through luminaire design.

MicroEmitter luminaires employ two distinct but complimentary methods to manage the life-limiting heat produced by the LED diode. Both conduction and convection are used to disperse heat, thereby maintaining diode performance and long life. Heat is drawn away from the housing chamber and dispersed into the free air around the luminaire. Additionally, each MicroEmitter module incorporates a solid aluminum heat sink, which is mechanically affixed to the EmitterDeck. The EmitterDeck is composed of a heavy gauge aluminum carrier plate to absorb and radiate additional heat for maximum cooling surface area.

Unfortunately, outdoor luminaires are subjected to a wide range of application environments from thermally mild (ex: San Francisco, CA) to thermally harsh (ex: Phoenix, AZ). In recognition of those environments exhibiting high average ambient temperatures, an additional level of thermal protection is provided within the MicroEmitter luminaire in the form of an active thermal self-monitoring and adjustment system. This system is called LifeShield™. Each EmitterDeck incorporates two temperature sensors located at positions thermally predicted to be the hottest locations of the back of the deck. Each sensor sends temperature readings every 30 seconds to the LifeShield control device located in the luminaire's electronic compartment. In high ambient conditions, LifeShield detects above tolerance temperature and automatically lowers the power to the MicroEmitters. The diodes are subtly dimmed to preserve diode life. Lumen output is restored to full capacity as the temperature is stabilized to within acceptable limits. These changes are gradual and subtle. Although the effective reduction in luminaire output is very slight, usually not visible, the impact on preserving diode life can be profound.

Figure 3

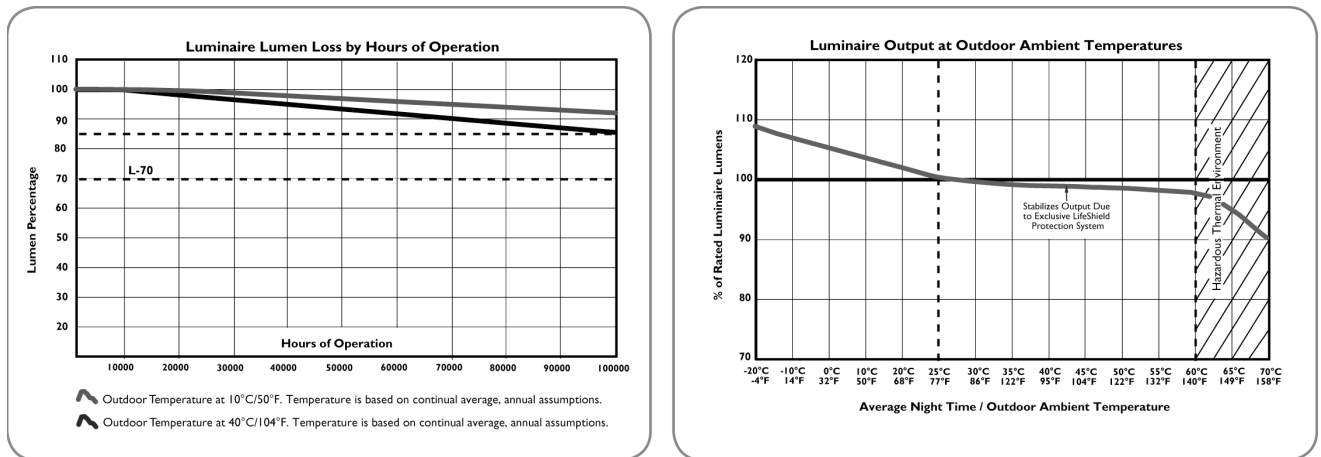

Notes:

- Lumen loss stabilization is a result of Kim Lighting's MicroEmitter luminaires exclusive LifeShield Protection System and Dual Heat Management System.
- The LifeShield Protection System will lower the current to the LEDs significantly if the luminaire is exposed to direct heat (sun) or excessive abnormal conditions.
- Luminaire Lumen Loss assumptions are based on LM-80 results and product testing based upon 5100K CCT, 350mA drive current, 25°C lab ambient and cathode temperature at 85°C. Assumptions past 6,000 hours are interpolated.

- Cathode temperature baseline is at 85°C. If cathode temperature increases during ambient changes and abnormal environment conditions, % of rated lumens will slightly decrease.
- Outdoor ambient temperatures are assumed SITU averages by geographic region.
- As Solid State Lighting technology and thermal management systems continually advance, lumen loss projections are subject to improvement.

10. Luminaire Upgrade Capability

Owners and facility managers are becoming increasingly interested in the capabilities of SSL luminaires to reduced their life cycle costs through reduced energy use and maintenance.

The modular approach central to the design of the MicroEmitter luminaire provides two great benefits in this regard:

- A. LED luminaires can be easily upgraded over time as LED technology advances. EmitterDecks are available for purchase as a field-installed replacement part. In this way, existing LED installations can be easily upgraded to the latest and greatest technology as it advances, as a great alternative to obsolescence or replacement and landfill.
- B. The existing installations of a wide range of popular Kim Lighting HID luminaires can be quickly and cost effectively upgraded to LED in the field through use of Kim's exclusive HID-to-LED Upgrade Kits. Unlike 3rd party retrofit kits, the Kim Upgrade Kits are designed and tested specifically *by Kim, for Kim*, and maintain the applicable UL/CSA/ETL listing and manufacturer's warranty.

11. Conclusion

LED technology holds great promise in the lighting industry today. Novel new approaches are required in order to properly apply this new light source. MicroEmitter technology in outdoor site, street, and parking applications has been shown to address the concerns of uniformity, glare, excess maximum footcandles (nadir dump), light trespass (usually behind the luminaire), light pollution (usually above 90°), and glare.. Nadir dump is eliminated through minimization of unnecessary and excessive lumen distribution beneath the luminaire. Light trespass is eliminated simply by not aiming any diodes beyond the target task area. Light pollution is eliminated by strictly limiting luminous intensity to below 90° through MicroEmitter aiming and spill light control. The result is exceptional luminous uniformity, visual comfort, and task efficacy. Furthermore, the modularity of the MicroEmitter allows for easy upgrade of existing HID luminaires to LED, providing a more sustainable alternative to replacement and landfill of existing luminaire housings.

Area/site luminaires employing the novel MicroEmitter technology provide designers and facility managers with optimal solid state lighting solutions to their lighting challenges.

Table 1. MicroEmitter Technology vs. LED Light Bar Luminaires

MicroEmitter Luminaires		LED Light Bar Luminaires
MicroEmitters contribute to high task efficacy, helping meet forthcoming new U.S. DOE requirements by precisely directing light to the task only.	TASK EFFICACY	Refractor-based LED luminaires may seem more efficient due to their higher luminaire efficacy, but their task efficacy is lower task because they cannot precisely direct light to the task only.
If MicroEmitters are not directed behind luminaire support poles, backlight is eliminated. This is possible without the added cost and work to attach house-side shields, which can be inefficient and unsightly. All consumed power contributes to illuminating the intended task.	BACKLIGHT ELIMINATION	The refractive optical control methods do not effectively limit spill light behind the pole. This wasteful use of consumed power is not neighbor-friendly, and may cause light trespass.
MicroEmitters are designed to produce max/min ratios as low as 3 1. This is achieved by boosting minimum footcandles far from the pole and severely restricting excess maximum footcandle levels directly under the pole (“nadir dump”).	UNIFORMITY	Higher LED Light Bar luminaires tend to have higher max/min ratios because they are ineffective at controlling “nadir dump,” resulting in wastefully high maximum footcandle levels directly under the pole.
LEDs are shielded by the EmitterReflector. Because each MicroEmitter is individually aimed, fewer than 50% of the LEDs are visible from any given viewing position, which considerably reduces glare. Additional shielding is provided by a perimeter reflector (GlareGuard) and deep regressing of the LEDs within the MicroEmitter housing.	GLARE CONTROL	LEDs are typically located at the lower surface of the luminaire and are exposed at all viewing angles, resulting in significant discomfort/ disability glare.
Because each MicroEmitter is visible only at certain viewing angles, the unlikely failure of an individual LED is unlikely to be noticeable to the viewer.	FAILED LED VISIBILITY	Because all LEDs are exposed at typical viewing angles, the unlikely failure of an individual LED may be visible.
3-LED MicroEmitters are sold as replacement parts and can be easily replaced in the field using wiring quick connects in the unlikely event of an individual LED failure.	MAINTENANCE	LED Light Bars (Typically 20 Diodes) are significantly more costly than individual 3-diode MicroEmitters. Since they cannot be to easily removed and replaced in most luminaires, correction of an individual LED failure is not practical.
EmitterDecks are sold as upgrade kits and are easily installed with 5 fasteners and electrical quick connects, allowing easy upgrade to the latest LED technology over time.	UPGRADE TO EXISTING	Since the LED Light Bars are not easily removed and replaced in most luminaires, upgradeability of existing installations to the latest LED technology may not be practical without complete luminaire disassembly or replacement.