

AC

Die-Cast Architectural Curvilinear Luminaire

Vertical or Horizontal Lamp

150 - 1000 Watt

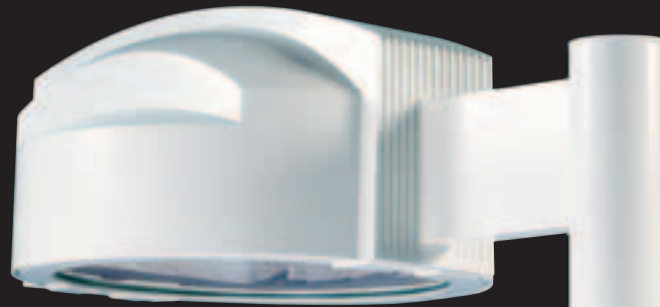

KIM LIGHTING

Architectural Curvilinear Series

Table of Contents

Relativity	2-3
Mechanical Features	4
Installation and Maintenance	5
Optical Configurations	6
Optical Features	7
Ordering Information	10-17
Proportion Guide	19
Application Engineering Services	20

Design

The bold new look of the AC Series is a creation inspired by form and function, molded by its aesthetic relationship to the architectural site. With its distinguishing "backbone" that structurally ties its post-top or side-arm mounting to the pole, AC employs a soft curvilinear form that reduces wind loading and visual mass when compared to bulky square fixtures. The sweeping curves are created by the backbone which contains the ballast and electrical components, and the body reveals, which actually conform to the interior geometry of the optical systems. Every element of the AC design is functional, yet the overall appearance is one of aesthetic unity.

Function

Available in two sizes, the AC Series is appropriately scaled for its range of lamps from 150 to 1000 Watts. To insure maximum flexibility in meeting illumination requirements, AC is available in both vertical and horizontal lamp optical systems, as well as numerous light distributions, rotatable reflectors, flat or convex lenses, and shielding for areas sensitive to light trespass. Ease of installation and maintenance are hallmarks of AC engineering, as well as materials, processes and finishes designed for longevity in the outdoor environment. Design, engineering and performance. The AC is the new standard for architectural outdoor luminaires.

21" AC 150 - 400 Watt

27" AC 750 - 1000 Watt

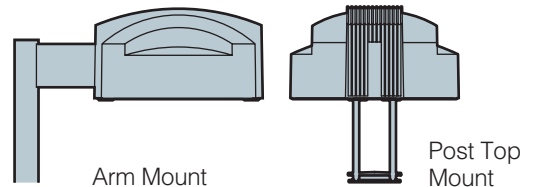
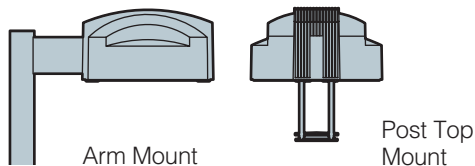

ISO 9001:2000



SITE / AREA
PARKING STRUCTURE
ROADWAY
ARCHITECTURAL FLOOD
ACCENT
LANDSCAPE

MAILING ADDRESS:
 P.O. BOX 60080
 CITY OF INDUSTRY, CA
 91716-0080

BUSINESS ADDRESS:
 16555 EAST GALE AVENUE
 CITY OF INDUSTRY, CA 91745
 U.S.A.

PHONE 626 / 968-5666
 FAX 626 / 369-2695

ENTIRE CONTENTS
 © COPYRIGHT 2004 KIM LIGHTING, INC.
 ALL RIGHTS RESERVED
 REPRODUCTION IN WHOLE OR IN PART
 WITHOUT PERMISSION IS STRICTLY PROHIBITED.
 PATENTS PENDING

www.kimlighting.com



Hubbell
Lighting, Inc.

Printed in U.S.A.
 5506604012
 Version 1/04





Kim Theory of Relativity

The Relationship of Outdoor Lighting to Site and Architecture



ACA AC Arm Mount



ACP AC Post Top Mount



BNS Bounce™



GEM™ Bollard



AFL Architectural Floodlight



WF Wall Forms®



SW Site Wallform



WD Wall Director®

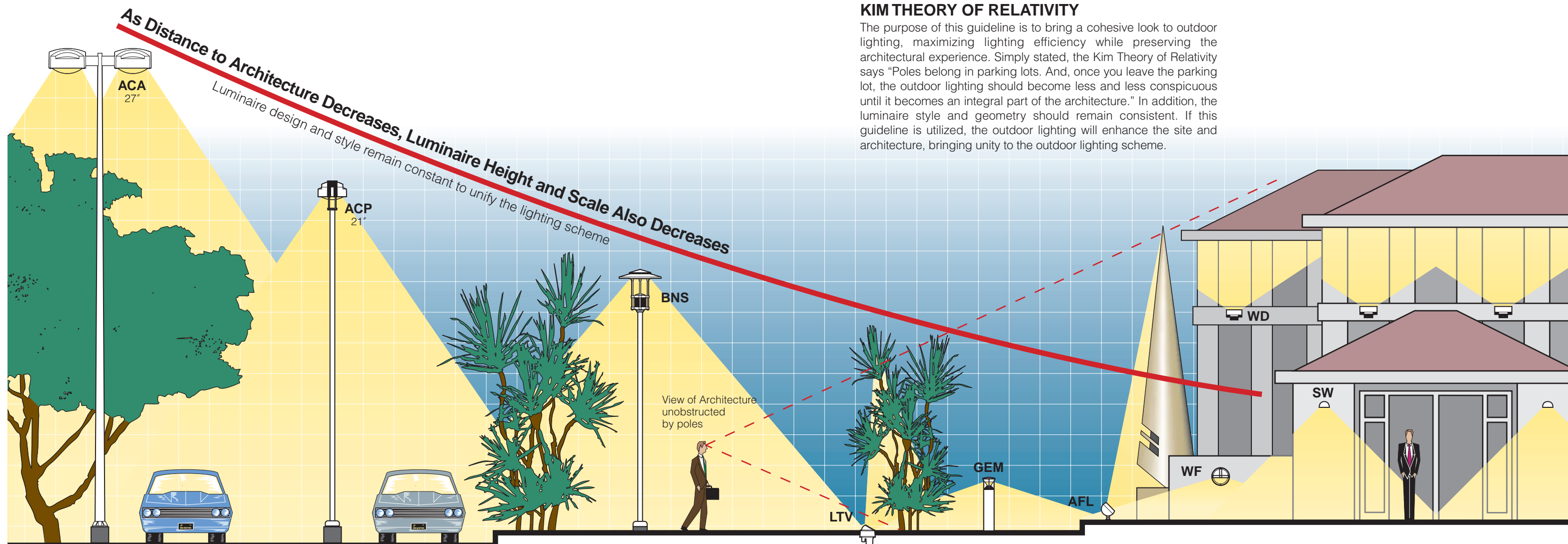

KIM THEORY OF RELATIVITY

The purpose of this guideline is to bring a cohesive look to outdoor lighting, maximizing lighting efficiency while preserving the architectural experience. Simply stated, the Kim Theory of Relativity says "Poles belong in parking lots. And, once you leave the parking lot, the outdoor lighting should become less and less conspicuous until it becomes an integral part of the architecture." In addition, the luminaire style and geometry should remain consistent. If this guideline is utilized, the outdoor lighting will enhance the site and architecture, bringing unity to the outdoor lighting scheme.

SITE / ROADWAY ZONE

Parking lots and roadways require luminaires on 20' - 40' poles to efficiently light these large areas. Therefore, this lighting becomes dominant, and sets the design and style for all other lighting as you progress towards the building.

PEDESTRIAN ZONE

As you leave the parking lot and transition to pedestrian areas, poles should decrease in height to 10' - 16'. In addition, luminaires should decrease in scale, and can have more decorative features to be appreciated at the pedestrian level.

LANDSCAPE / PATH ZONE

Near the building, luminaires should begin to disappear, blending into the landscape and hardscape elements.

BUILDING / PERIMETER ZONE

No pole mounted luminaires should ever be used near the building, as they will dominate the architecture. The only exception would be the use of decorative luminaires to delineate entrances to the structure. Building mounted, architecturally compatible fixtures should be almost invisible.

Mechanical Features

Die-Cast Housings and Lens Frames

Housing and lens frame are one-piece aluminum die castings for precision and reliability. Integral cooling fins on the housing reduce operating temperatures, promoting extended life for the electrical components.

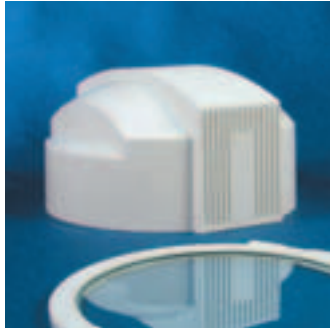

Die-Cast Reflectors

All optical systems utilize specular reflector components mounted in one-piece aluminum die-cast reflectors. Each die cast reflector forms a sealed chamber to eliminate airborne contaminants, and provides for precision and repeatability in the manufacturing process.



Pre-Wired Ballast Module

The ballast and related electrical components are mounted to a single bracket, creating a removable electrical module. All components are pre-wired at the factory with quick-disconnect plugs, and keyhole slots facilitate mounting inside the housing.



Kim pioneered the ballast module concept to reduce down time and replacement costs. Spare ballast modules may be ordered and stored at the facility. Should a ballast failure occur, a spare module can be immediately inserted while the old one is repaired, and kept as a future replacement.

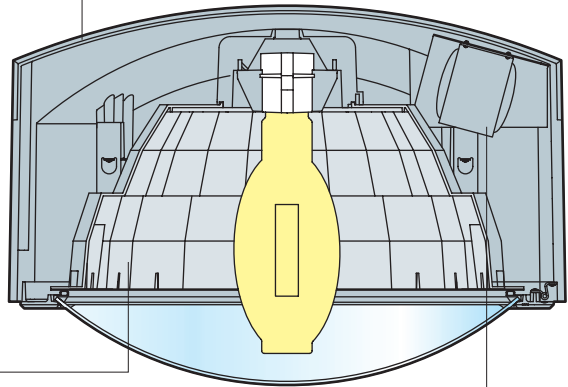

Side Arm or Post Top Mounting

Side arm mounting allows one to four fixtures per pole depending on illumination requirements. For projects where one fixture per pole is adequate, a centered post top mounting is available using a twin yoke support that blends into the housing backbone.

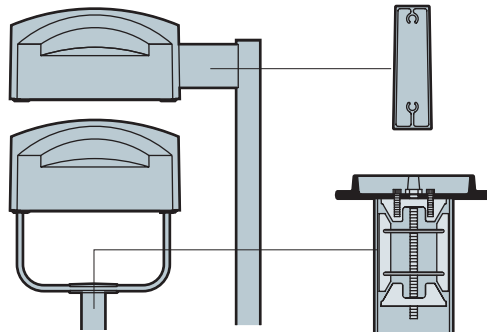

Side arm is a one-piece aluminum extrusion, with centering guides for the concealed internal draw bolts which connect the housing to the pole. See page 5.

Post top mount is available with Kim's patented wedge grip, a concealed internal expansion device activated by a single bolt within the hub. See page 5.

Eight Stage Durable Powder Coat Finish

Kim's state-of-the-art powder coat paint system is engineered to provide the highest quality finish with absolute paint adhesion under weather extremes. The Super TGIC thermoset polyester powder coat finish is applied over a Titanated Zirconium conversion coating. This finish system has exceeded the A.S.T.M. 2500 hour salt spray test.

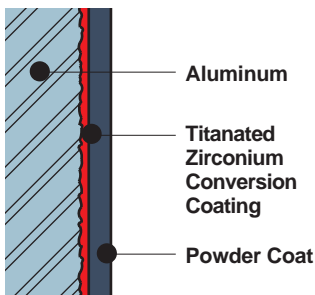

1. Power wash and degrease.
2. Detergent tank bath.
3. Clear water rinse bath.
4. Premium Titanated Zirconium conversion coating as used in the automobile industry.
5. Clear water rinse bath.
6. Dry off oven.
7. Powder coating, 2.5 mil nominal thickness.
8. Bake for 20 minutes at 410°F.

Standard Super TGIC Colors

- BL-P** Black
- DB-P** Dark Bronze
- LG-P** Light Gray
- PS-P** Platinum Silver
- WH-P** White

Installation and Maintenance Features



Concealed Mounting Bolts

Side arm mounting is accomplished by internal draw bolts within the arm, preserving the clean detailing of the AC. Bolts are accessed inside the housing with the reflector removed. A steel reinforcing plate inside the pole, receives the bolts and also provides strain relief for field wires.



Tool-less Entry

Internal access for installation and maintenance is accomplished with stainless steel thumb latches. In addition, a support arm locks the housing and lens frame in the open position, freeing both hands to work.

Flush Post Top Mounting

Post top mounting is available with Kim's patented wedge grip. A single mounting bolt is concealed within the hub, which also serves as the splice compartment for attachment of field wires to the fixture. The mounting bolt expands an internal device within the pole, attaching the fixture with no visible fasteners.



Easy Ballast Access

To access the ballast module in either post top or side arm fixtures, the die cast reflector snaps out without the need for tools. A quick disconnect plug detaches the reflector wires from the ballast module.



Easy Removal of Ballast Module

With the reflector removed, the entire ballast module can be removed by loosening four screws. Quick disconnect plugs detach the ballast wiring from the field wiring, and the ballast module is slipped out of its keyhole slots.



4 Optical Configurations

See the **Site / Roadway Optical Systems Catalog** for in-depth discussion of design and application.

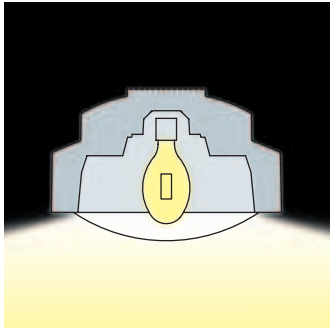

Vertical Lamp Convex Lens Wide Throw Semi-Cutoff

This very wide throw, semi-cutoff configuration is ideal for large parking areas. Maximum pole spacing is achieved with excellent uniformity of illumination. A moderate degree of fixture brightness, as seen from a distance, signals to customers or visitors that the business is open, and well-illuminated for safety and security.

Available Distributions:



Wide
Symmetric
Square



Wide
Asymmetric

Options:

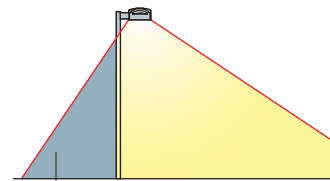

Houseside shielding available on W3 only.

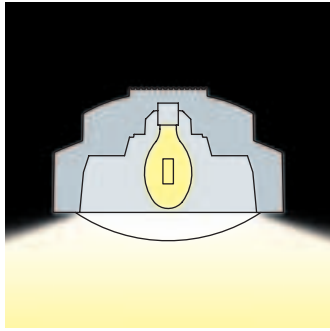

Vertical Lamp Convex Lens Medium Throw Cutoff

This medium throw configuration is ideal where lower fixture brightness is desired. Rated "Cutoff", this vertical lamp system still provides excellent light throw and uniformity, with much lower brightness as seen from beyond the property lines.



Medium
Symmetric
Square



Medium
Asymmetric

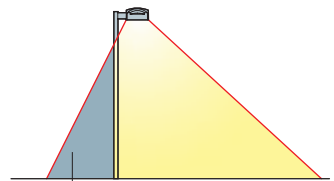

Houseside shielding available on M3 only.

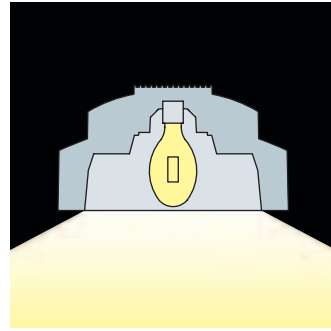

Vertical Lamp Flat Lens Narrow Throw Full Cutoff

Utilizing a flat lens in combination with a vertical lamp, this configuration is ideal where strict control of upward light is desired or mandated. Because of the vertical lamp orientation, the throw is narrow, but very uniform. If greater throw is desired, consider using the horizontal lamp configuration as shown at right.



Narrow
Symmetric
Square



Narrow
Asymmetric

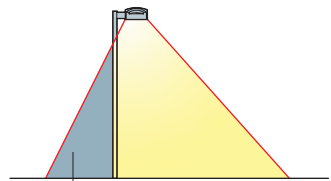

Houseside shielding available on N3 only.

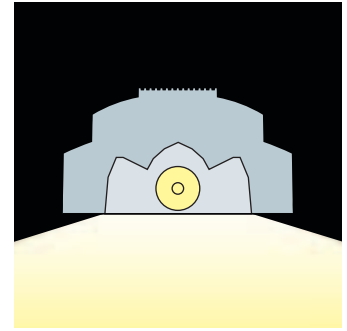

Horizontal Lamp Flat Lens Full Cutoff

This flat lens, horizontal lamp configuration provides full cutoff with the flexibility of four light distributions. The throw is wide, but the lighting is not quite as uniform as a vertical lamp system. This configuration is ideal for lighting projects with many areas of different shapes. Here, the four light distributions can be used to precisely illuminate only the required areas.

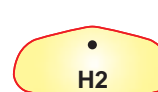

Type II



Type III



Type IV



Type V
Square

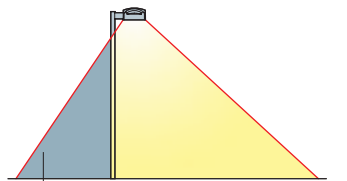

Houseside shielding available on Types II, III, and IV.

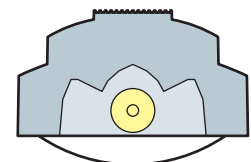

Convex lens available for greater fixture presence.

Sealed Optical System

Die-cast reflectors allow the AC optical systems to be totally sealed from moisture, dust, insects and air pollution. These contaminants can enter the optical system from outside the luminaire, and from the inside through wireways. By creating a totally sealed chamber, the optical system maintains maximum efficiency between standard maintenance cycles. A one piece silicone gasket, with ends fused together, is utilized to seal the interfaces between reflector, lens and lens frame. All wires to the socket are sealed at point of entry into the reflector, insuring a totally sealed optical system.

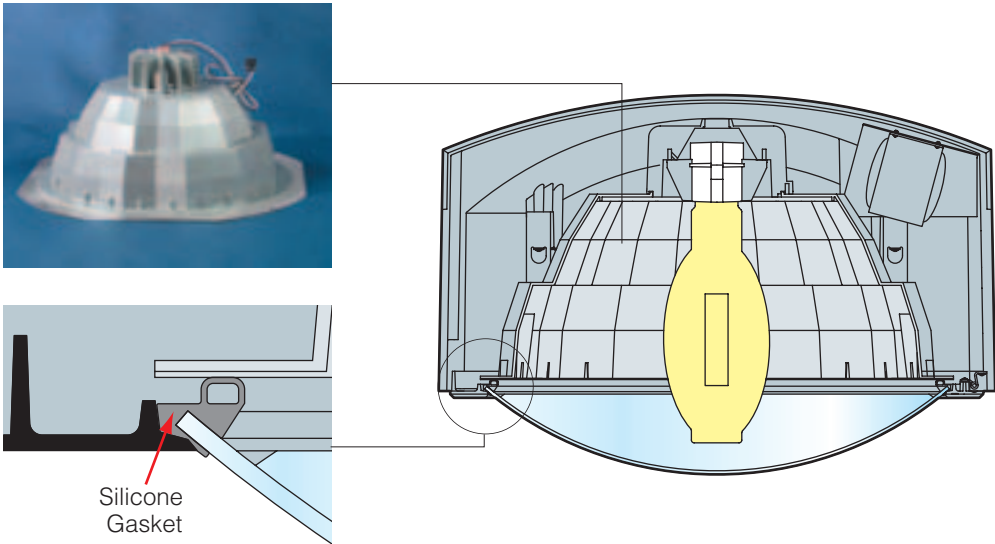

Rotatable Optics

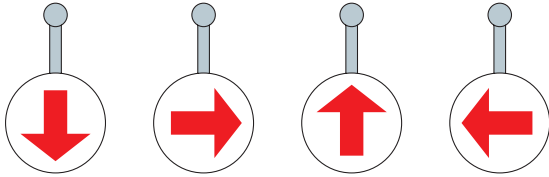

All asymmetric reflectors are field rotatable in 90° degree increments. This allows design flexibility to maintain a consistent fixture orientation throughout the site, or to produce very high illumination levels for special applications.

For example, twin mounted luminaires would normally be mounted on poles with the reflector orientation (Arrow) pointing away from the pole. In the example at right, all twin mounts have the fixture orientations in the same direction, yet the reflectors are rotated to produce a variety of combined light patterns.

The same principal applies to the single post top mount also shown at right. Here, the fixture yokes are orientated in the same direction, but the reflectors are rotated to place the asymmetric light pattern in different directions.

For applications demanding high light levels such as tennis courts and auto dealerships, reflectors can be oriented in parallel to double the light levels. Houseside shields can also be added to the fixtures for reduced spill light into unwanted areas behind the luminaires.

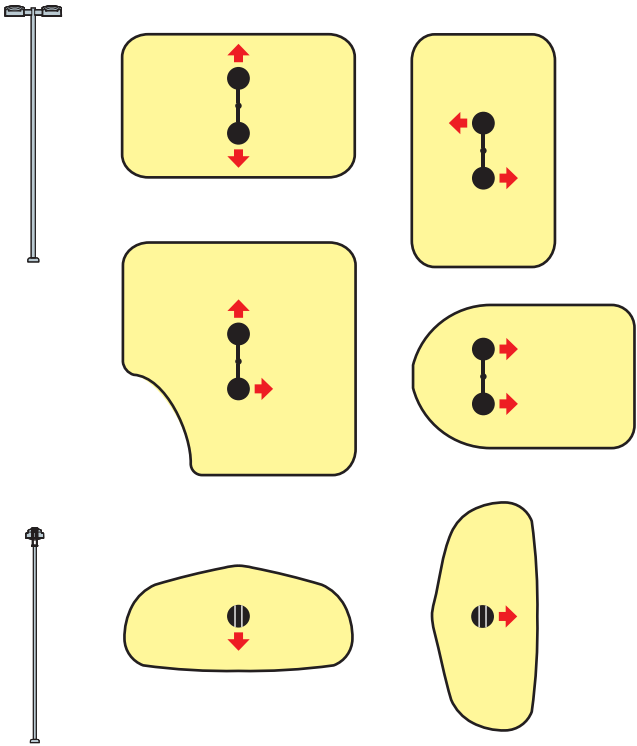

Split Beam Reflector Geometry

Unless properly engineered, wide-throw vertical lamp optical systems will redirect light back into the lamp, causing reduced efficiency and lamp life. To eliminate this problem, all AC vertical lamp reflectors employ split beam geometry.

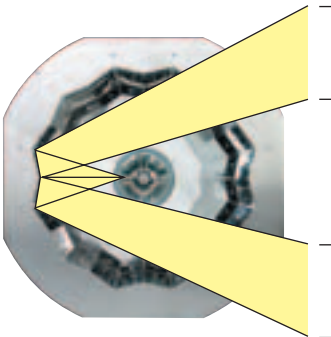

Reflected light does not pass through the lamp envelope, which otherwise will reduce lamp life and efficiency.

Split beams of reflected light pass freely and efficiently out of the luminaire.





Ordering Information

Vertical Lamp Arm Mount

Ordering Example:

For Standard Fixture and Pole

Mounting Fixture Electrical Module Finish Options Pole

2B / ACA21C.W5 / 400PMH277 / LG-P / A-33 / PRA30-6250 / LG-P

1

2

3

4

5-10

11

See separate Kim Pole Catalog.
Omit for **1W** Wall Mount.

1 Mounting:

3Y configuration is available for round poles only.

Plan View:

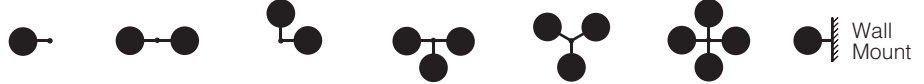

Cat. No.:	1A	2B	2L	3T	3Y	4C	1W
EPA 21":	1.8	3.6	2.8	4.0	4.0	4.2	
27":	2.7	5.4	3.6	5.9	5.9	6.3	

2 Fixture:

Cat. No. designates **AC** fixture, light distribution and beam spread.

See the Kim Site/Roadway Optical Systems Catalog for detailed information on reflector design and application.

Light Distribution:

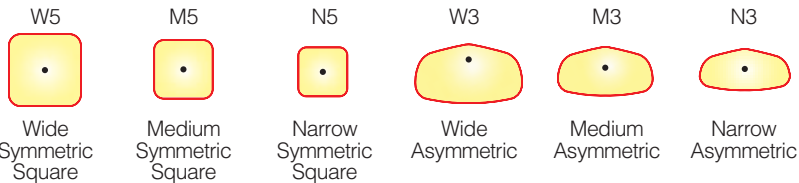

21" Convex Lens	ACA21C.W5	ACA21C.M5	n/a	ACA21C.W3	ACA21C.M3	n/a
21" Flat Lens	n/a	n/a	ACA21F.N5	n/a	n/a	ACA21F.N3
27" Convex Lens	ACA27C.W5	ACA27C.M5	n/a	ACA27C.W3	ACA27C.M3	n/a
27" Flat Lens	n/a	n/a	ACA27F.N5¹	(N/A)	n/a	ACA27F.N3¹

¹NOTE: ED37 lamp required for Narrow Beam, Flat Lens models.

3 Electrical Module:

HPS = High Pressure Sodium

MH = Metal Halide

PMH = Pulse Start Metal Halide

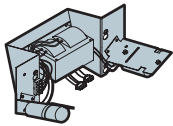

Lamp Watts	Lamp Type	Line Volts
400	HPS	277

See lamp and electrical data on pages 24 - 25 for ballast types and characteristics.

ACA21			ACA27		
150HPS120	250HPS120	400HPS120	750HPS120	1000HPS120²	² NOTE: ED37 lamp required for Narrow Beam, Flat Lens models.
150HPS208	250HPS208	400HPS208	750HPS208	1000HPS208²	
150HPS240	250HPS240	400HPS240	750HPS240	1000HPS240²	
150HPS277	250HPS277	400HPS277	750HPS277	1000HPS277²	
150HPS347	250HPS347	400HPS347	750HPS347	1000HPS347²	
150HPS480	250HPS480	400HPS480	750HPS480	1000HPS480²	
175MH120	250MH120	400MH120	1000MH120		
175MH208	250MH208	400MH208	1000MH208		
175MH240	250MH240	400MH240	1000MH240		
175MH277	250MH277	400MH277	1000MH277		
175MH347	250MH347	400MH347	1000MH347		
175MH480	250MH480	400MH480	1000MH480		
175PMH120	250PMH120	400PMH120	750PMH120	1000PMH120	
175PMH208	250PMH208	400PMH208	750PMH208	1000PMH208	
175PMH240	250PMH240	400PMH240	750PMH240	1000PMH240	
175PMH277	250PMH277	400PMH277	750PMH277	1000PMH277	
175PMH347	250PMH347	400PMH347	750PMH347	1000PMH347	
175PMH480	250PMH480	400PMH480	750PMH480	1000PMH480	

4 Finish:

Super TGIC powder coat paint over Titanated Zirconium conversion coating.

Color:	Black	Dark Bronze	Light Gray	Platinum Silver	White	Custom Colors
Cat. No.:	BL-P	DB-P	LG-P	PS-P	WH-P	CC-P

Consult representative for custom colors.

5 Optional Photocell:

Factory installed photocell in housing with fully gasketed sensor on side wall.

* - Fixture with photocell
S - Slave unit(s)

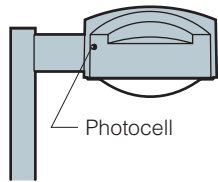

Mounting	Wattage per fixture	Voltage	Cat. No.
1A, 1W 2B 2L 3T, 3Y	150 to 400W	120 208 240 277 480 347	A-30 A-31 A-32 A-33 A-34 A-35
4C	150 to 250W	Each fixture has a photocell	
4C	400W	120 208 240 277 480 347	2A-30 2A-31 2A-32 2A-33 2A-34 2A-35

6 Optional Polycarbonate Lens:

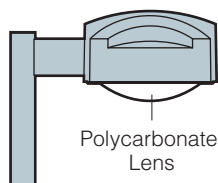

Cat. No.: **L21**
For ACA21 only.
Not available for ACA27.

Polycarbonate Lens replaces standard tempered glass lens. 250 watt maximum. May be used with 400HPS in outdoor locations where ambient air temperature during fixture operation will not exceed 85°F. See **“CAUTION”** on page 19.

7 Optional Houseside Shield:

Available for asymmetric light distributions only.

Recommended for clear lamps only. Effectiveness is reduced with coated lamps.

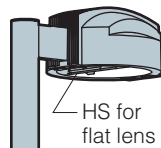

Cat. No.: **HS**

For fixtures with flat lens and asymmetric light distribution only. Do not use with square light distribution.

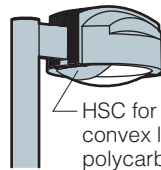

Cat. No.: **HSC**

For fixtures with convex lens and asymmetric light distribution only. Do not use with square light distribution.

8 Optional Vertical Slipfitter Mounts:

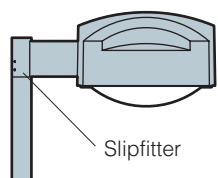

Cat. No.
VSF-1A
VSF-2B
VSF-2L
VSF-3T
VSF-3Y
VSF-4C

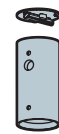

4" Round

Cat. No.
SVSF-1A
SVSF-2B
SVSF-2L
SVSF-3T

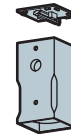

SVSF-4C 4" Square

Mounting Configuration
1A - Single arm mount
2B - 2 at 180°
2L - 2 at 90°
3T - 3 at 90°
3Y - 3 at 120°
4C - 4 at 90°

Allows standard fixture and arm to be mounted to poles having a 2" pipe-size steel tenon (2 3/8" O.D. x 4 1/2" minimum length).

9 Optional Horizontal Slipfitter Mount:

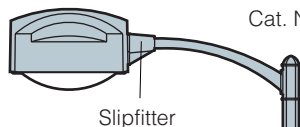

Cat. No.: **HSF**

Replaces standard mounting arm with a slipfitter for mounting to a horizontal pole davit-arm with 2" pipe-size mounting end (2 3/8" O.D.).

10 Optional Fusing:

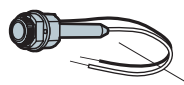

Line Volts:	120V	208V	240V	277V	480V	347V
Cat. No.:	SF	DF	DF	SF	DF	SF

Single Fuse

11 Poles:

See Kim Pole Catalog for a complete selection of round and square poles in aluminum or steel. Any poles listed for VL and CC fixtures may be used for the AC.

Ordering Information

Vertical Lamp Post Top Mount

Ordering Example:

For Standard Fixture and Pole

Mounting Fixture Electrical Module Finish Options Pole

FM/ ACP21C.W5 / 400PMH277 / LG-P / A-33 / PRA30-6188 / LG-P

1 2 3 4 5-8 9

See separate Kim Pole Catalog.

1 Mounting:

21" 27"

EPA: 1.3 2.1



Cat. No.: **FM** Flush Mount **PT** Pole Tenon Mount **DM** Direct Mount

Pole Top Requirements: 4", 4½", 5", or 6" Dia. 2" Pipe-size Tenon (2¾" O.D. x 4¾" L.) 3.1" to 3.9" Dia.

2 Fixture:

Cat. No. designates **AC** fixture, light distribution and beam spread.

See the Kim Site/Roadway Optical Systems Catalog for detailed information on reflector design and application.

Light Distribution:



Wide Symmetric Square

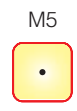

Medium Symmetric Square

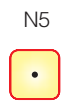

Narrow Symmetric Square

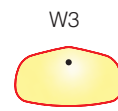

Wide Asymmetric

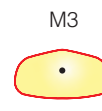

Medium Asymmetric

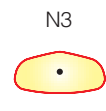

Narrow Asymmetric



Convex Lens

ACP21C.W5

ACP21C.M5

n/a

ACP21C.W3

ACP21C.M3

n/a



Flat Lens

n/a

n/a

ACP21F.N5

n/a

n/a

ACP21F.N3

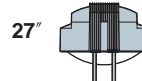

Convex Lens

ACP27C.W5

ACP27C.M5

n/a

ACP27C.W3

ACP27C.M3

n/a



Flat Lens

n/a

n/a

ACP27F.N5¹

n/a

n/a

ACP27F.N3¹

¹**NOTE:** ED37 lamp required for Narrow Beam, Flat Lens models.

3 Electrical Module:

HPS = High Pressure Sodium

MH = Metal Halide

PMH = Pulse Start Metal Halide

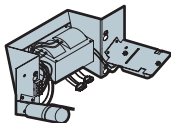

Lamp Watts	Lamp Type	Line Volts
400	HPS	277

See lamp and electrical data on pages 24 - 25 for ballast types and characteristics.

ACP21

150HPS120	250HPS120	400HPS120
150HPS208	250HPS208	400HPS208
150HPS240	250HPS240	400HPS240
150HPS277	250HPS277	400HPS277
150HPS347	250HPS347	400HPS347
150HPS480	250HPS480	400HPS480
175MH120	250MH120	400MH120
175MH208	250MH208	400MH208
175MH240	250MH240	400MH240
175MH277	250MH277	400MH277
175MH347	250MH347	400MH347
175MH480	250MH480	400MH480

175PMH120	250PMH120	400PMH120
175PMH208	250PMH208	400PMH208
175PMH240	250PMH240	400PMH240
175PMH277	250PMH277	400PMH277
175PMH347	250PMH347	400PMH347
175PMH480	250PMH480	400PMH480

ACP27

750HPS120	1000HPS120 ²
750HPS208	1000HPS208 ²
750HPS240	1000HPS240 ²
750HPS277	1000HPS277 ²
750HPS347	1000HPS347 ²
750HPS480	1000HPS480 ²
1000MH120	
1000MH208	
1000MH240	
1000MH277	
1000MH347	
1000MH480	

750PMH120	1000PMH120
750PMH208	1000PMH208
750PMH240	1000PMH240
750PMH277	1000PMH277
750PMH347	1000PMH347
750PMH480	1000PMH480

²**NOTE:** ED37 lamp required for Narrow Beam, Flat Lens models.

4 Finish:

Super TGIC powder coat paint over Titanated Zirconium conversion coating.

Color: Black Dark Bronze Light Gray Platinum Silver White Custom Colors

Cat. No.: **BL-P** **DB-P** **LG-P** **PS-P** **WH-P** **CC-P**

Consult representative for custom colors.

5 Optional Photocell:

Factory installed photocell in housing with fully gasketed sensor on side wall.

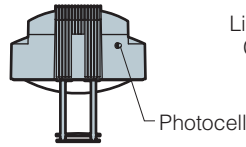

Line Volts:	120V	208V	240V	277V	480V	347V
Cat. No.:	A-30	A-31	A-32	A-33	A-34	A-35

Available on all fixtures in all wattages.

6 Optional Polycarbonate Lens:

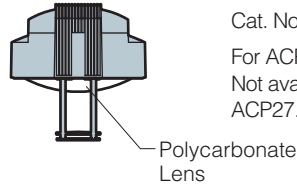

Cat. No.: **L21**
For ACP21 only.
Not available for ACP27.

Polycarbonate Lens replaces standard tempered glass lens. 250 watt maximum. May be used with 400HPS in outdoor locations where ambient air temperature during fixture operation will not exceed 85°F. See **CAUTION** on page 21.

7 Optional Houseside Shield:

Available for asymmetric light distributions only.

Recommended for clear lamps only. Effectiveness is reduced with coated lamps.

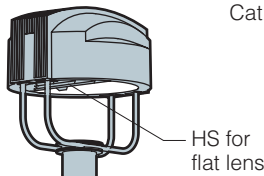

Cat. No.: **HS**

For fixtures with flat lens and asymmetric light distribution only. Do not use with square light distribution.

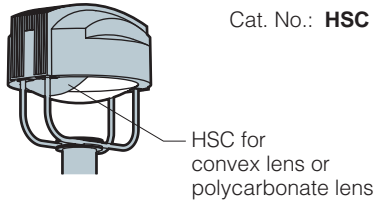

Cat. No.: **HSC**

For fixtures with convex lens and asymmetric light distribution only. Do not use with square light distribution.

8 Optional Fusing:

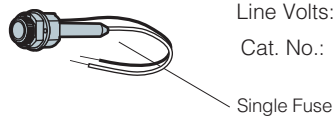

Line Volts:	120V	208V	240V	277V	480V	347V
Cat. No.:	SF	DF	DF	SF	DF	SF

9 Poles:

See Kim Pole Catalog for a complete selection of round and square poles in aluminum or steel. Any poles listed for VL and CC fixtures may be used for the AC.

Ordering Information

Horizontal Lamp Arm Mount

Ordering Example:

For Standard Fixture and Pole

Mounting Fixture Electrical Module Finish Options Pole

2B / ACA21C.H2 / 400PMH277 / LG-P / A-33 / PRA30-6250 / LG-P

1 2 3 4 5-10 11

See separate Kim Pole Catalog.
Omit for **1W** Wall Mount.

1 Mounting:

3Y configuration is available for round poles only.

Plan View:

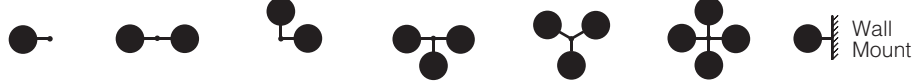

Cat. No.:	1A	2B	2L	3T	3Y	4C	1W
EPA 21":	1.8	3.6	2.8	4.0	4.0	4.2	
27":	2.7	5.4	3.6	5.9	5.9	6.3	

2 Fixture:

Cat. No. designates **AC** fixture, light distribution and beam spread.

See the Kim Site/Roadway Optical Systems Catalog for detailed information on reflector design and application.

Light Distribution:



Type II Type III Type IV Type V Square

21" Convex Lens	ACA21C.H2	ACA21C.H3	ACA21C.H4	ACA21C.H5
Flat Lens	ACA21F.H2	ACA21F.H3	ACA21F.H4	ACA21F.H5
27" Convex Lens	ACA27C.H2	ACA27C.H3	ACA27C.H4	ACA27C.H5
Flat Lens	ACA27F.H2	ACA27F.H3	ACA27F.H4	ACA27F.H5

3 Electrical Module:

HPS = High Pressure Sodium

MH = Metal Halide

PMH = Pulse Start Metal Halide

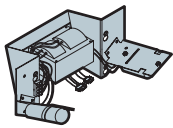

Lamp Watts	Lamp Type	Line Volts
400	HPS	277

See lamp and electrical data on pages **24 - 25** for ballast types and characteristics.

ACA21			ACA27		
150HPS120	250HPS120	400HPS120	750HPS120	1000HPS120	
150HPS208	250HPS208	400HPS208	750HPS208	1000HPS208	
150HPS240	250HPS240	400HPS240	750HPS240	1000HPS240	
150HPS277	250HPS277	400HPS277	750HPS277	1000HPS277	
150HPS347	250HPS347	400HPS347	750HPS347	1000HPS347	
150HPS480	250HPS480	400HPS480	750HPS480	1000HPS480	
175MH120	250MH120	400MH120	1000MH120		
175MH208	250MH208	400MH208	1000MH208		
175MH240	250MH240	400MH240	1000MH240		
175MH277	250MH277	400MH277	1000MH277		
175MH347	250MH347	400MH347	1000MH347		
175MH480	250MH480	400MH480	1000MH480		
	250PMH120	400PMH120	750PMH120	1000PMH120	
	250PMH208	400PMH208	750PMH208	1000PMH208	
	250PMH240	400PMH240	750PMH240	1000PMH240	
	250PMH277	400PMH277	750PMH277	1000PMH277	
	250PMH347	400PMH347	750PMH347	1000PMH347	
	250PMH480	400PMH480	750PMH480	1000PMH480	

4 Finish:

Super TGIC powder coat paint over Titanated Zirconium conversion coating.

Color:	Black	Dark Bronze	Light Gray	Platinum Silver	White	Custom Colors
Cat. No.:	BL-P	DB-P	LG-P	PS-P	WH-P	CC-P

Consult representative for custom colors.

5 Optional Photocell:

Factory installed photocell in housing with fully gasketed sensor on side wall.

* - Fixture with photocell
S - Slave unit(s)

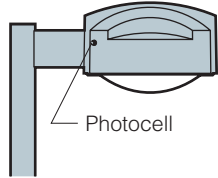

Mounting		Wattage per fixture		Voltage	Cat. No.		
1A, 1W	* 2B S	2L S	3T, 3Y	150 to 400W	750 & 1000W	120 208 240 277 480 347	A-30 A-31 A-32 A-33 A-34 A-35
S 4C		S 4C		150 to 250W	Each fixture has a photocell		
S 4C		S 4C		400W		120 208 240 277 480 347	2A-30 2A-31 2A-32 2A-33 2A-34 2A-35

6 Optional Polycarbonate Lens:

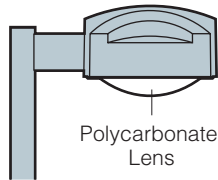

Cat. No.: **L21**
For ACA21 only.
Not available for ACA27.

Polycarbonate Lens replaces standard tempered glass lens. 250 watt maximum. May be used with 400HPS in outdoor locations where ambient air temperature during fixture operation will not exceed 85°F. See "**CAUTION**" on page 19.

7 Optional Houseside Shield:

Available for Type II, III and IV light distributions only.

Recommended for clear lamps only. Effectiveness is reduced with coated lamps.

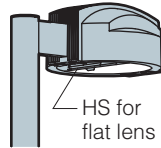

Cat. No.: **HS**

For fixtures with flat lens and asymmetric light distribution only. Do not use with square light distribution.

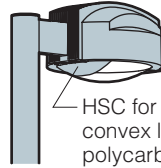

Cat. No.: **HSC**

For fixtures with convex lens and asymmetric light distribution only. Do not use with square light distribution.

8 Optional Vertical Slipfitter Mounts:

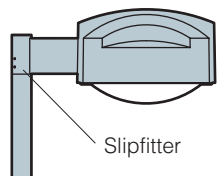

Cat. No.
VSF-1A
VSF-2B
VSF-2L
VSF-3T
VSF-3Y
VSF-4C



4" Round

Cat. No.
SVSF-1A
SVSF-2B
SVSF-2L
SVSF-3T
SVSF-4C

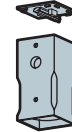

4" Square

Mounting Configuration
1A - Single arm mount
2B - 2 at 180°
2L - 2 at 90°
3T - 3 at 90°
3Y - 3 at 120°
4C - 4 at 90°

Allows standard fixture and arm to be mounted to poles having a 2" pipe-size steel tenon (2 3/8" O.D. x 4 1/2" minimum length).

9 Optional Horizontal Slipfitter Mount:

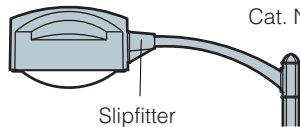

Cat. No.: **HSF**

Replaces standard mounting arm with a slipfitter for mounting to a horizontal pole davit-arm with 2" pipe-size mounting end (2 3/8" O.D.).

10 Optional Fusing:

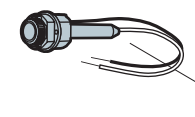

Line Volts:	120V	208V	240V	277V	480V	347V
Cat. No.:	SF	DF	DF	SF	DF	SF

Single Fuse

11 Poles:

See Kim Pole Catalog for a complete selection of round and square poles in aluminum or steel. Any poles listed for VL and CC fixtures may be used for the AC.

Ordering Information

Horizontal Lamp Post Top Mount

Ordering Example:

For Standard Fixture and Pole

Mounting Fixture Electrical Module Finish Options Pole

FM/ ACP21C.H2 / 400PMH277 / LG-P / A-33 / PRA30-6188 / LG-P

1 2 3 4 5-8 9

See separate Kim Pole Catalog.

1 Mounting:

21" 27"

EPA: 1.3 2.1



Cat. No.: **FM** Flush Mount **PT** Pole Tenon Mount **DM** Direct Mount

Pole Top Requirements: 4", 4½", 5", or 6" Dia. 2" Pipe-size Tenon (2¾" O.D. x 4¾" L.) 3.1" to 3.9" Dia.

2 Fixture:

Cat. No. designates **AC** fixture, light distribution and beam spread.

See the Kim Site/Roadway Optical Systems Catalog for detailed information on reflector design and application.

Light Distribution:



Type II



Type III



Type IV



Type V Square

21"  **ACP21C.H2 ACP21C.H3 ACP21C.H4 ACP21C.H5**

Convex Lens



Flat Lens

ACP21F.H2 ACP21F.H3 ACP21F.H4 ACP21F.H5

27"  **ACP27C.H2 ACP27C.H3 ACP27C.H4 ACP27C.H5**

Convex Lens



Flat Lens

ACP27F.H2 ACP27F.H3 ACP27F.H4 ACP27F.H5

3 Electrical Module:

HPS = High Pressure Sodium

MH = Metal Halide

PMH = Pulse Start Metal Halide

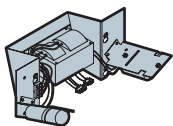

Lamp Watts	Lamp Type	Line Volts
400	HPS	277

See lamp and electrical data on pages 24 - 25 for ballast types and characteristics.

ACP21

150HPS120	250HPS120	400HPS120
150HPS208	250HPS208	400HPS208
150HPS240	250HPS240	400HPS240
150HPS277	250HPS277	400HPS277
150HPS347	250HPS347	400HPS347
150HPS480	250HPS480	400HPS480
175MH120	250MH120	400MH120
175MH208	250MH208	400MH208
175MH240	250MH240	400MH240
175MH277	250MH277	400MH277
175MH347	250MH347	400MH347
175MH480	250MH480	400MH480

ACP27

750HPS120	1000HPS120
750HPS208	1000HPS208
750HPS240	1000HPS240
750HPS277	1000HPS277
750HPS347	1000HPS347
750HPS480	1000HPS480
1000MH120	
1000MH208	
1000MH240	
1000MH277	
1000MH347	
1000MH480	
750PMH120	1000PMH120
750PMH208	1000PMH208
750PMH240	1000PMH240
750PMH277	1000PMH277
750PMH347	1000PMH347
750PMH480	1000PMH480

4 Finish:

Super TGIC powder coat paint over Titanated Zirconium conversion coating.

Color: Black Dark Bronze Light Gray Platinum Silver White Custom Colors

Cat. No.: **BL-P** **DB-P** **LG-P** **PS-P** **WH-P** **CC-P**

Consult representative for custom colors.

5 Optional Photocell:

Factory installed photocell in housing with fully gasketed sensor on side wall.

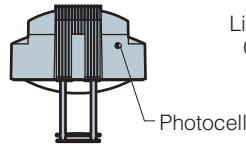

Line Volts:	120V	208V	240V	277V	480V	347V
Cat. No.:	A-30	A-31	A-32	A-33	A-34	A-35

Available on all fixtures in all wattages.

6 Optional Polycarbonate Lens:

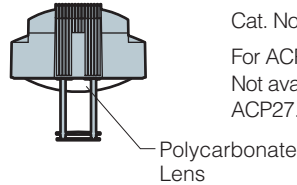

Cat. No.: **L21**
For ACP21 only.
Not available for ACP27.

Polycarbonate Lens replaces standard tempered glass lens. 250 watt maximum. May be used with 400HPS in outdoor locations where ambient air temperature during fixture operation will not exceed 85°F. See **CAUTION** on page 21.

7 Optional Houseside Shield:

Available for Type II, III and IV light distributions only.

Recommended for clear lamps only. Effectiveness is reduced with coated lamps.

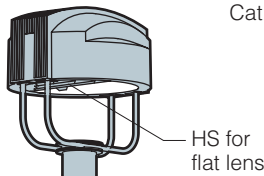

Cat. No.: **HS**

For fixtures with flat lens and asymmetric light distribution only. Do not use with square light distribution.

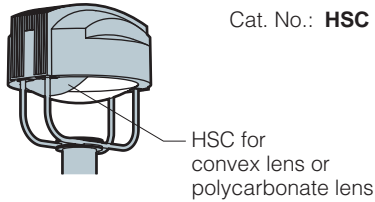

Cat. No.: **HSC**

For fixtures with convex lens and asymmetric light distribution only. Do not use with square light distribution.

8 Optional Fusing:

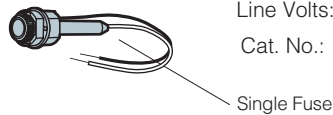

Line Volts:	120V	208V	240V	277V	480V	347V
Cat. No.:	SF	DF	DF	SF	DF	SF

9 Poles:

See Kim Pole Catalog for a complete selection of round and square poles in aluminum or steel. Any poles listed for VL and CC fixtures may be used for the AC.



21" and 27" Fixtures / 20' to 50' Poles

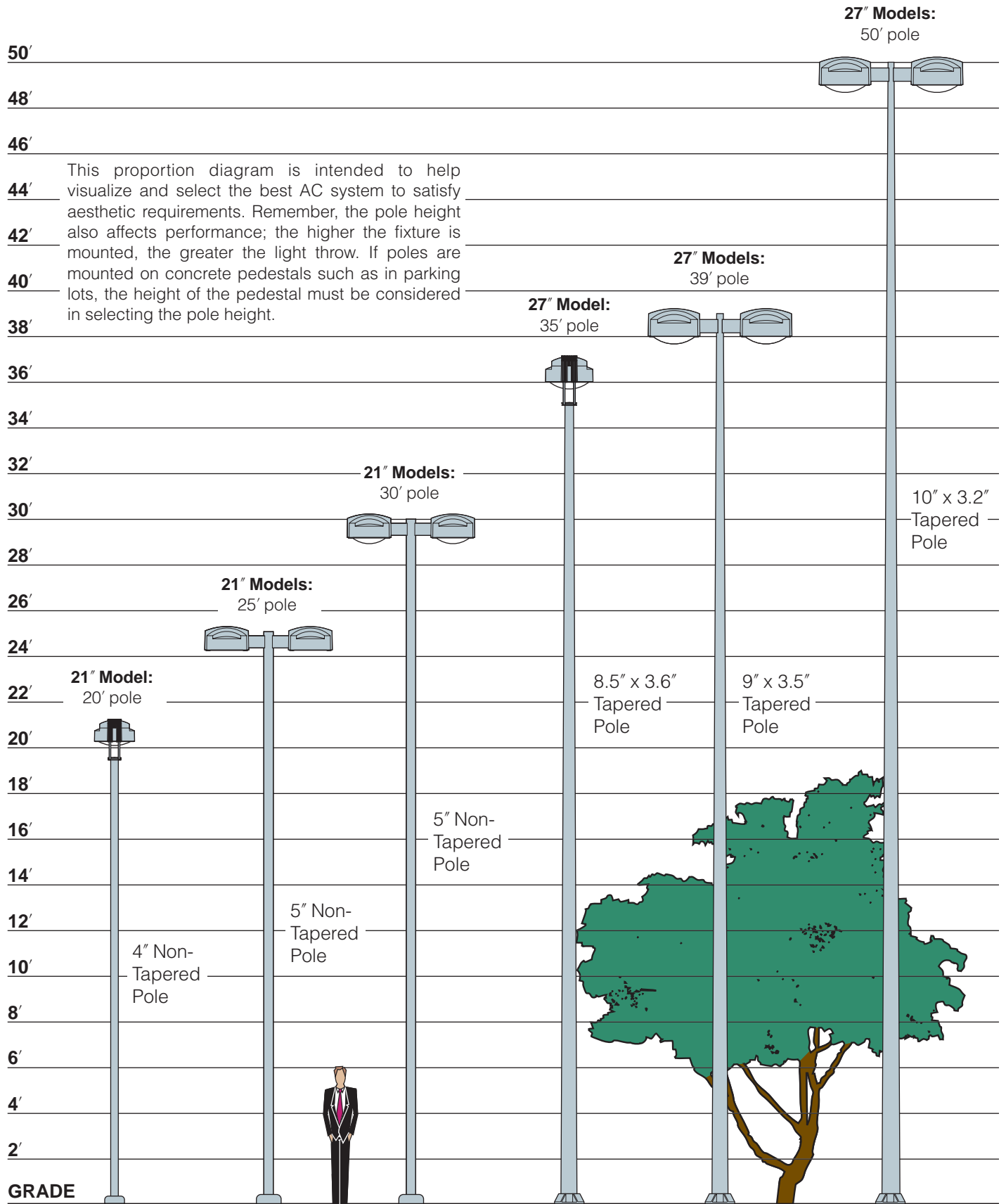



Applications Assistance

Kim Lighting utilizes the latest computer technology and software to provide specifiers with reliable evaluations of lighting system performance.

Kim can analyze a proposed luminaire layout or provide recommendations based on performance criteria.

Hard copies of plans can be sent directly to the Kim Applications Department via fax, express or regular mail. Any .dwg or .dxf file can be transmitted via modem or email (**kim.apps@kimlighting.com**), or placed on diskette, CD ROM or Zip disk, and forwarded to Kim Lighting c/o Kim Apps.



Photometric Files

Kim photometric files are available free in both electronic and hard copy format.

Electronic photometric files include .pdf file format pages for printing and .ies files for use in lighting calculation software. The complete .ies / .pdf library is available on CD ROM and on the internet at **www.kimlighting.com**.